



**Technical Service
Information Bulletin**

March 10, 2004

Title:
ZERO POINT CALIBRATION

Models:
'04 All Models with VSC

**BRAKES
BR001-04**

Introduction The following information is intended to clarify the repair manual procedures for Zero Point Calibration and sensor checks after the replacement of any of the following components or procedures.



- Vehicle Stability Control Computer
- Steering Angle Sensor
- Yaw Rate Sensor
- Deceleration Sensor
- After Performing an Alignment

Zero Point Calibration of the above sensors must also be performed when replacing or repairing steering related parts. These steps are necessary for the correct and accurate repair of VSC related systems.

Applicable Vehicles

- **All 2004** model year **Lexus** vehicles **equipped with VSC**.

Required SSTs

SPECIAL SERVICE TOOLS (SSTs)	PART NUMBER	QUANTITY
Lexus Diagnostic Tester Kit* 	01001270	1
CAN Interface Module Kit* 	01002744	1
12 Megabyte Diagnostic Tester Program Card with version 10.2a Software (or later)* 	01002593-005	1
Diagnostic Check Wire* (or equivalent)	09843-18040	1

* Essential SSTs.

NOTE:

Additional Diagnostic Tester Kits, CAN Interface Modules, Program Cards or other SSTs may be ordered by calling SPX/OTC at 1-800-933-8335.

Warranty Information

OP CODE	DESCRIPTION	TIME	OFF	T1	T2
N/A	Not Applicable to Warranty	—	—	—	—



Lexus Supports ASE Certification

Calibration Procedure With Diagnostic Tester

Zero Point Calibration Procedure Using Diagnostic Tester

1. Connect Diagnostic Tester to DLC3.

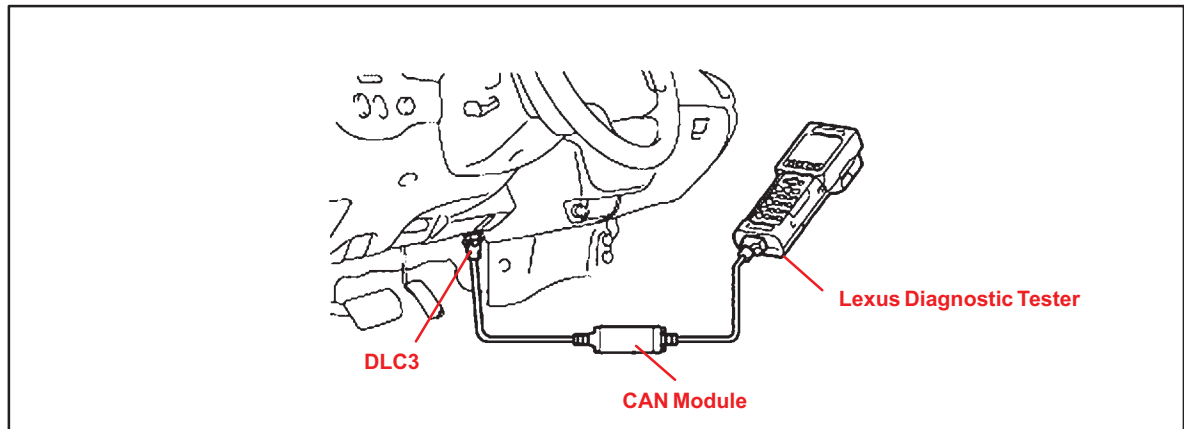

2. Follow the flow below for the calibration procedure. If the vehicle is equipped with automatic transmission (A/T), ensure that the shift lever is in the “P” range and the parking brake is applied. If the vehicle is equipped with manual transmission (M/T), ensure that the parking brake is applied.

NOTE:
 While performing the Zero Point Calibration, do not tilt, move or shake the vehicle. The vehicle must remain in a stationary condition throughout the entire process. Be sure to perform the procedure on a level surface with an inclination of less than 1%.

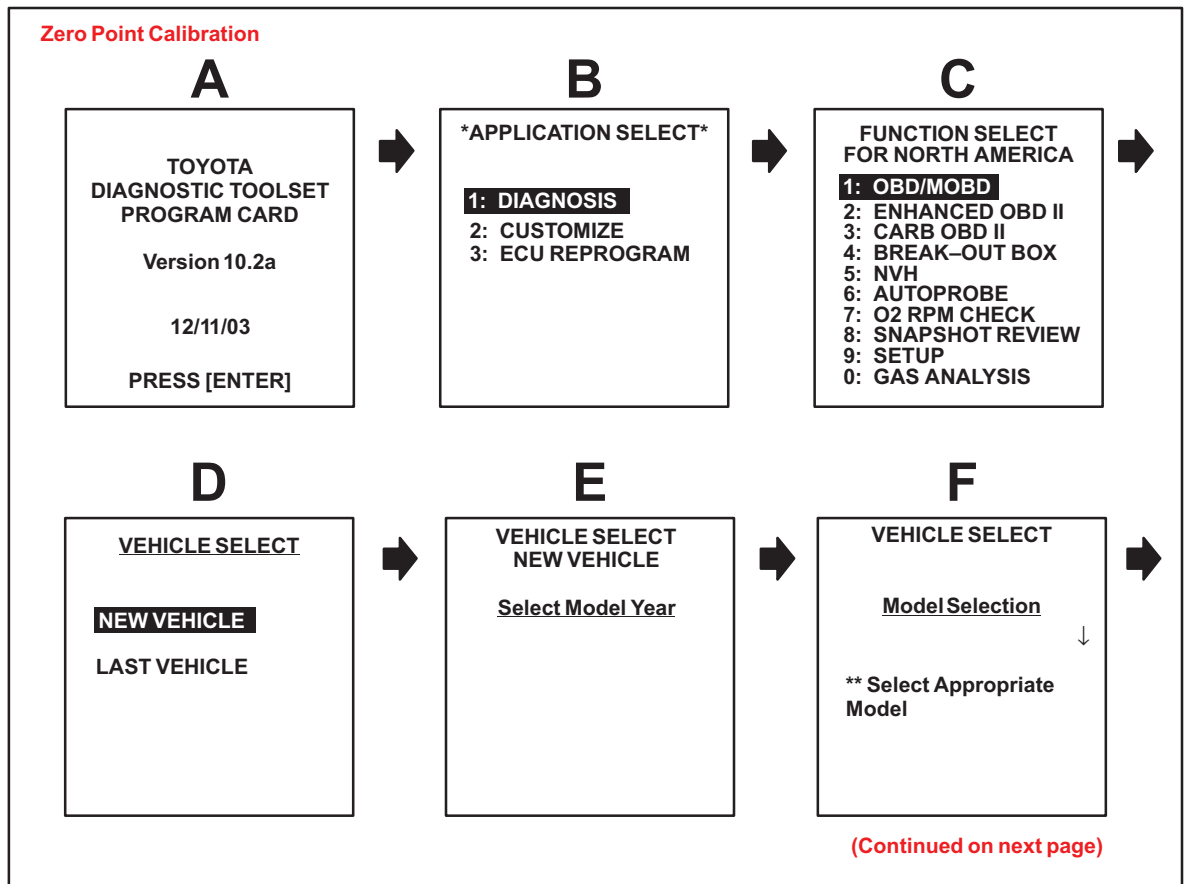

Calibration Procedure With Diagnostic Tester (Continued)

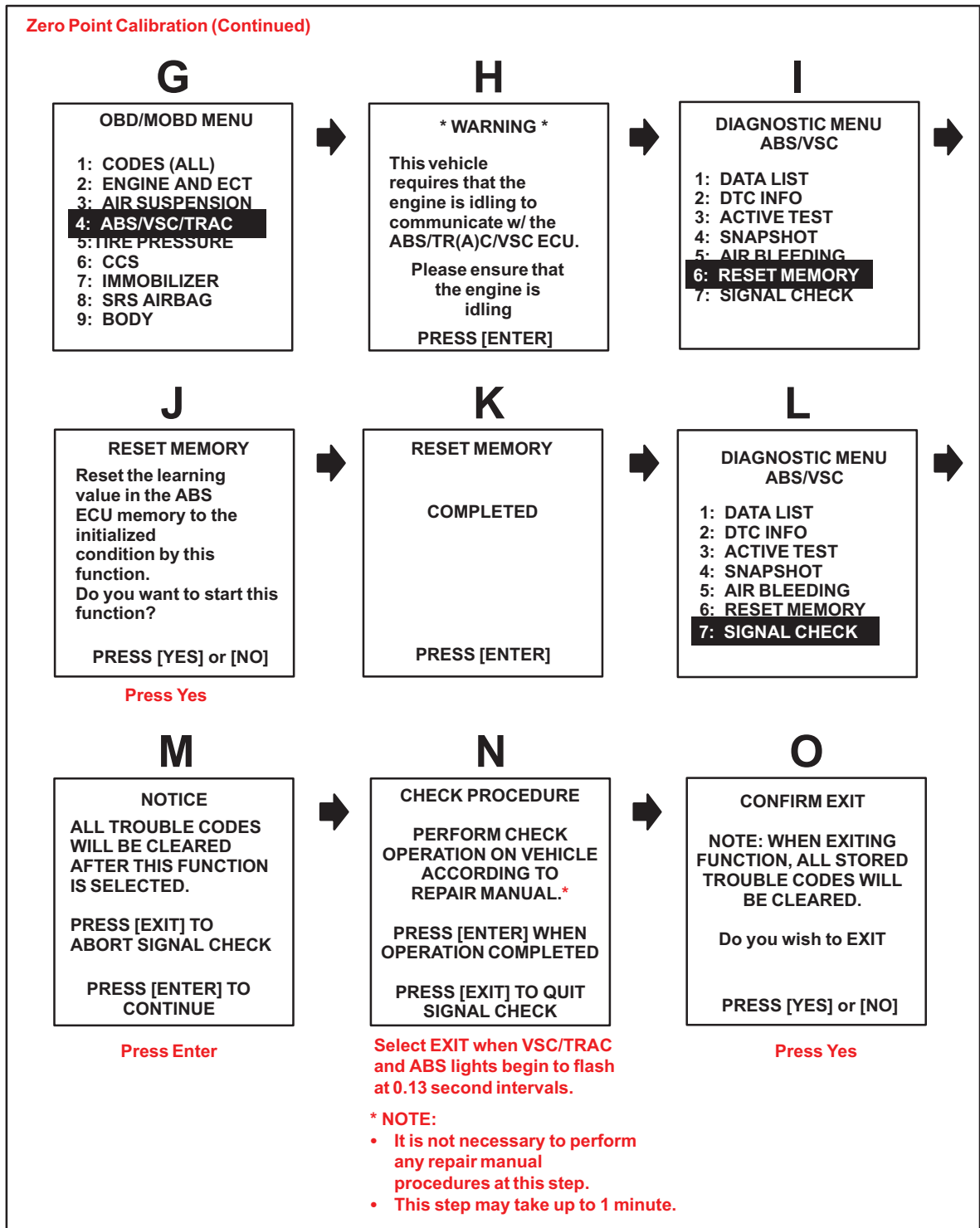

3. Drive the vehicle for **at least 5 minutes** to confirm Zero Point Calibration is complete.

NOTE:
If viewing Diagnostic Tester Data List after repair, the Steering Angle Sensor may remain at 1150 until the vehicle reaches 28 mph. This is a normal condition until the learned values of the steering angle have been achieved.

**Calibration
Procedure
With SST****Zero Point Calibration Using SST 09843–18040**

The following procedure may be used in the cases where a Diagnostic Tester is not available.

NOTE:

While performing the Zero Point Calibration, do not tilt, move or shake the vehicle. The vehicle must remain in a stationary condition throughout the entire process. Be sure to perform the procedure on a level surface with an inclination of less than 1%.

1. Ensure the shift lever is in the “P” range.
2. Turn the ignition switch ON.
3. Using SST 09843–18040, repeat a cycle of short and open between terminals Ts and CG of DLC3 4 times or more within 8 seconds (refer to the specific vehicle EWD for TS and CG pin location in the DLC3).
4. Verify that the VSC indicator light is lit indicating the recorded zero point is erased.
5. Turn the ignition switch OFF.
6. Be sure the terminals Ts and CG of DLC3 are disconnected.
7. Turn the ignition switch ON.
8. Check that the VSC warning light goes off about 15 seconds after the ignition switch is turned ON.
9. After ensuring that the VSC warning light remains OFF for 2 seconds, turn the ignition switch OFF.
10. Connect terminals Ts and CG of DLC3 using SST 09843–18040.
11. Turn the ignition switch ON.
12. After turning the ignition switch ON, check that the VSC warning light is lit for about 4 seconds and then starts quick blinking at 0.13 second intervals.
13. After ensuring the blinking of the VSC warning light for 2 seconds, turn the ignition switch OFF.
14. Remove the SST from terminals Ts and CG of DLC3.
15. Drive the vehicle for **at least 5 minutes** to confirm Zero Point Calibration is complete.

NOTE:

If viewing Diagnostic Tester Data List after repair, the Steering Angle Sensor may remain at 1150 until the vehicle reaches 28 mph. This is a normal condition until the learned values of the steering angle have been achieved.