

AERODYNAMICS

■ DESCRIPTION

To improve aerodynamics performance, the following measures have been taken.

- The adoption of the parts below provides smooth airflow around the tires and reduces the air resistance while the vehicle is in motion.

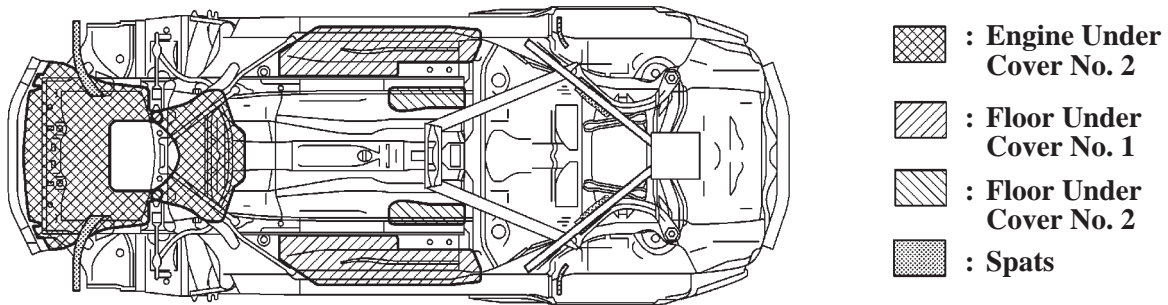

199BO14

- A wind deflector has been provided to reduce the amount of airflow rolling in from the back while the vehicle is in motion.

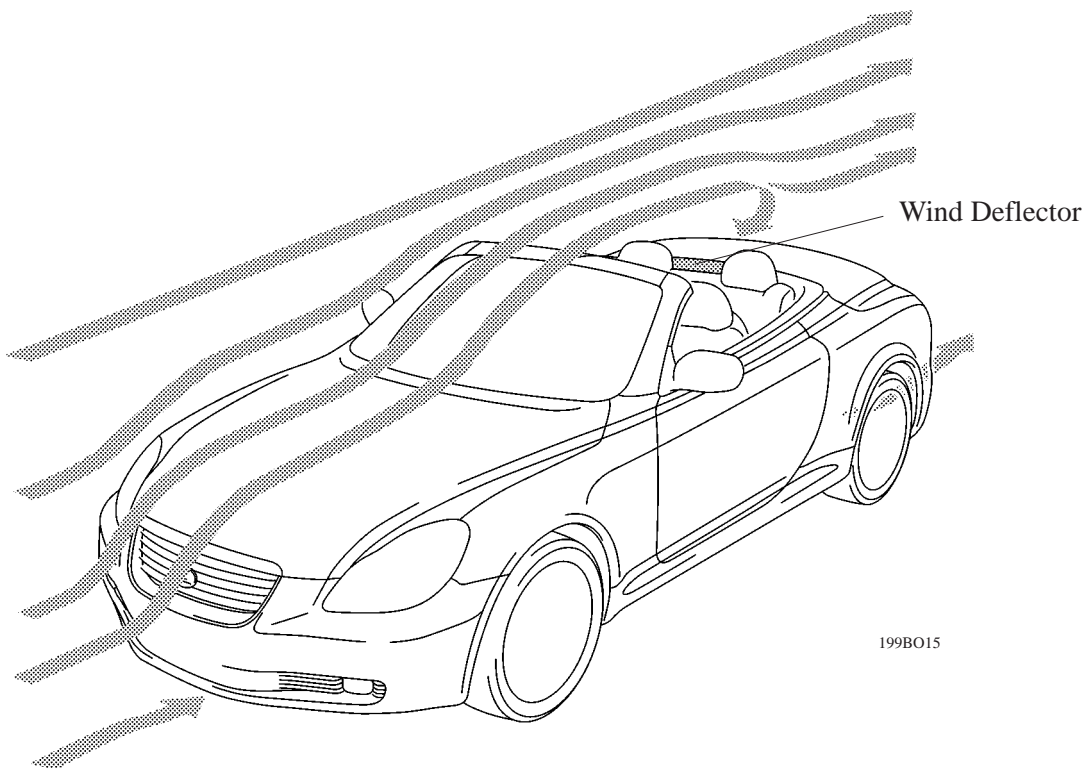

199BO15