

REAR BRAKE Disc Brake COMPONENTS

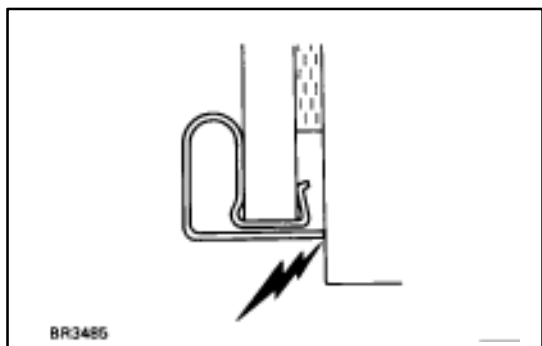
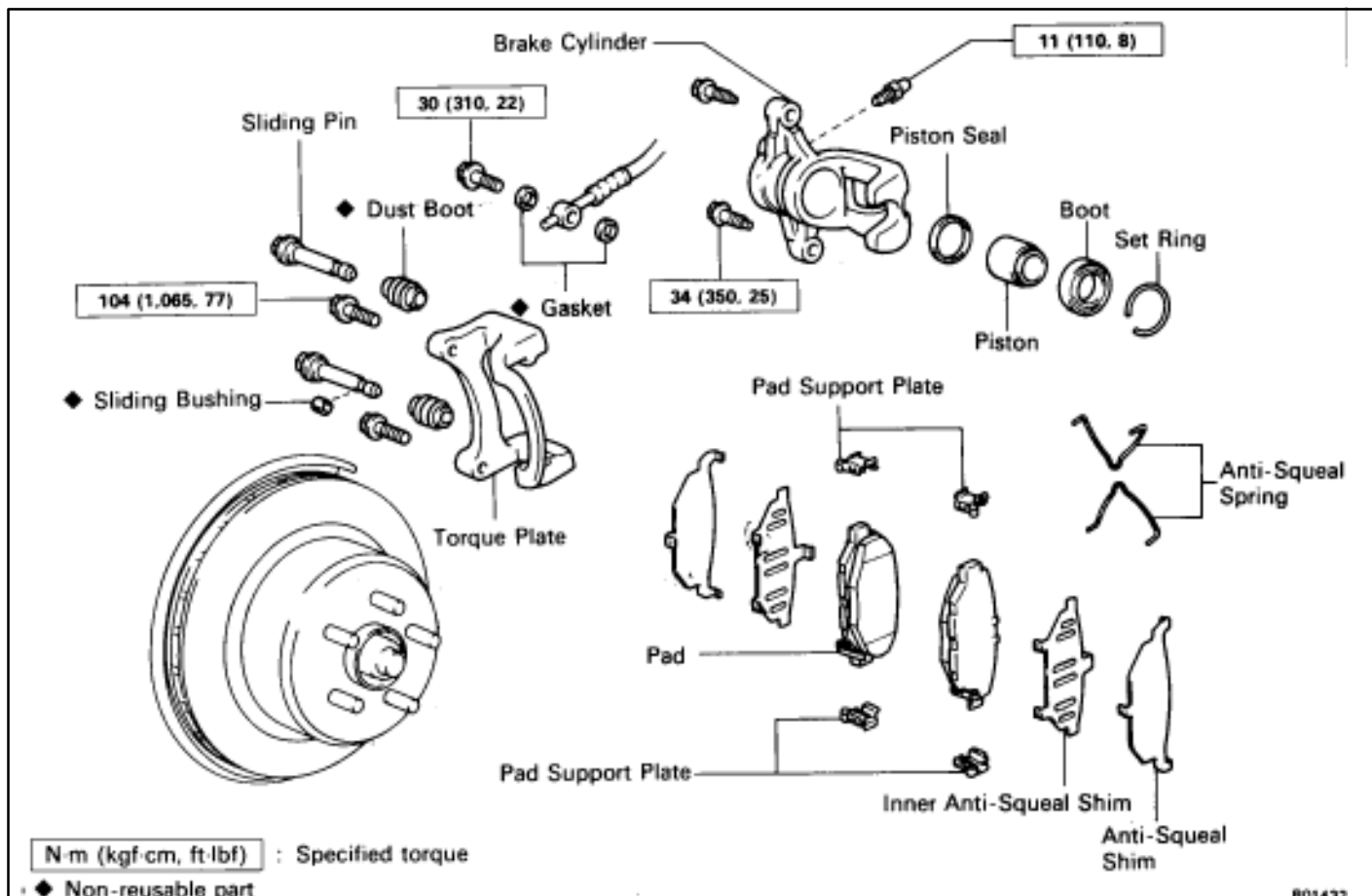

REPLACEMENT OF BRAKE PADS

HINT: If a squealing noise is made by the rear brakes while driving, check the pad wear indicator. If there is evidence of the indicator contacting the rotor disc, the brake pads should be replaced.

1. REMOVE REAR WHEEL

Remove the wheel and temporarily fasten the rotor disc with the hub nuts.

2. INSPECT PAD LINING BRAKE

Check the pad thickness through the cylinder inspection hole and replace the pads if the thickness is not within the specification.

Minimum thickness: 1.0 mm (0.039 in.)

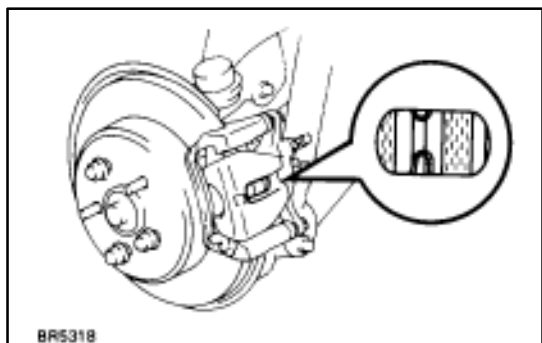

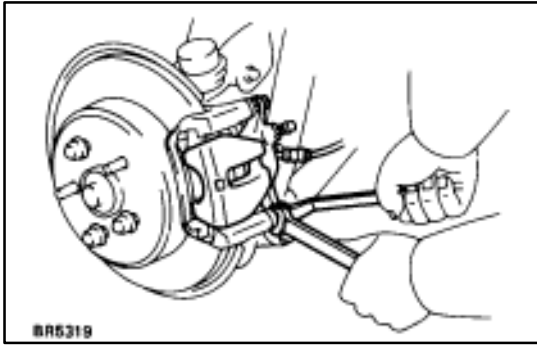

3. LIFT UP CYLINDER

- (a) Hold the sliding pin on the bottom and loosen the installation bolt.
- (b) Remove the installation bolt.

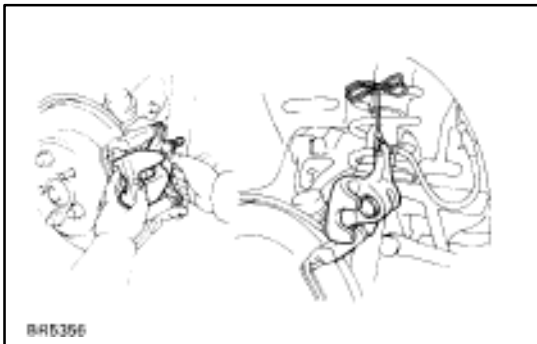

- (c) Lift up the brake cylinder and suspend the cylinder with string.

HINT: Do not disconnect the flexible hose from the brake cylinder.



4. REMOVE FOLLOWING PARTS:

- (a) Two anti-squeal springs
- (b) Two brake pads
- (c) Four anti-squeal shims
- (d) Four pad support plates

5. CHECK ROTOR DISC THICKNESS

(See step 2 on page [BR-32](#))

6. CHECK ROTOR DISC RUNOUT

(See step 3 on page [BR-32](#))

7. INSTALL PAD SUPPORT PLATES

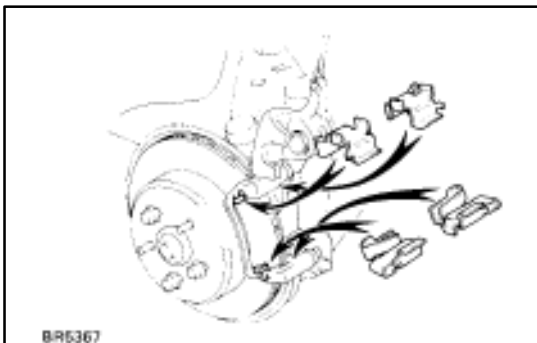

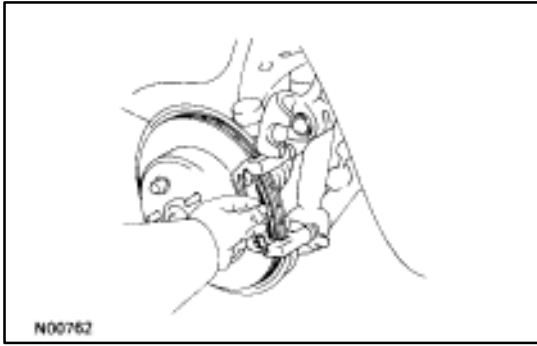

8. INSTALL NEW PADS

- (a) Apply disc brake grease to both sides of the inner anti-squeal shim.
- (b) Install the two anti-squeal shims on each pad.
- (c) Install two pads with the pad wear indicator plates facing downward.

NOTICE: There should be no oil or grease adhering to the friction surfaces of the pads or the rotor disc.

- (d) Install the two anti-squeal springs.

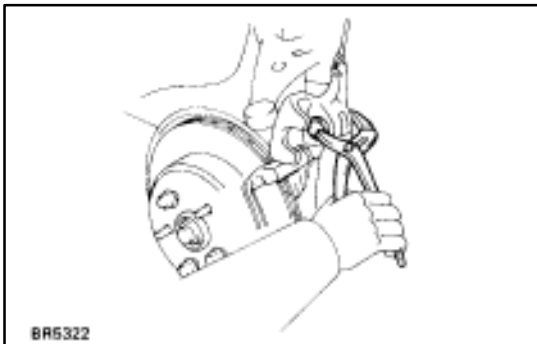

9. INSTALL CYLINDER

- (a) Draw out a small amount of brake fluid from the reservoir tank.
- (b) Press in the piston with water pump pliers or similar implement.

HINT: If the piston is difficult to push in, loosen the bleeder plug and push in the piston while letting some brake fluid escape.

- (c) Install the cylinder.
- (d) Hold the sliding pin and torque the installation bolt.

Torque: 34 N·m (350 kgf·cm, 25 ft·lbf)

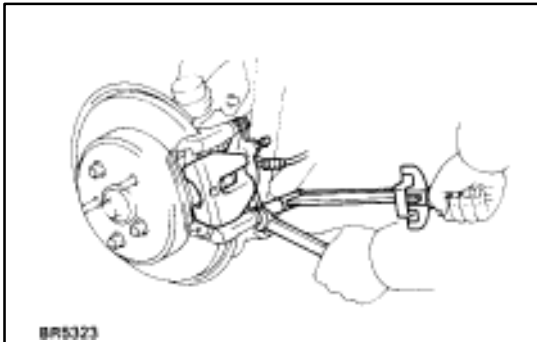

10. INSTALL REAR WHEEL

11. CHECK THAT FLUID LEVEL IS AT MAX LINE

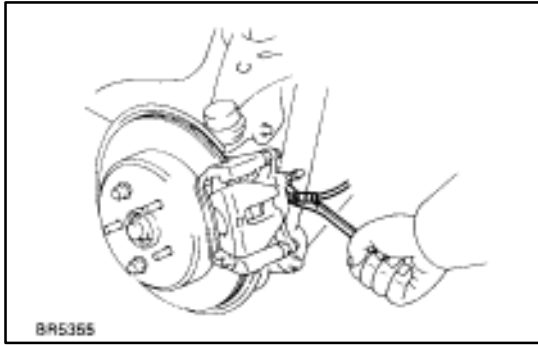

REMOVAL OF CYLINDER

(See page [BR-27](#))

1. DISCONNECT FLEXIBLE HOSE

- (a) Remove the union bolt and two gaskets from the brake cylinder, then disconnect the flexible hose from the brake cylinder.
- (b) Use a container to catch the brake fluid as it drains out.

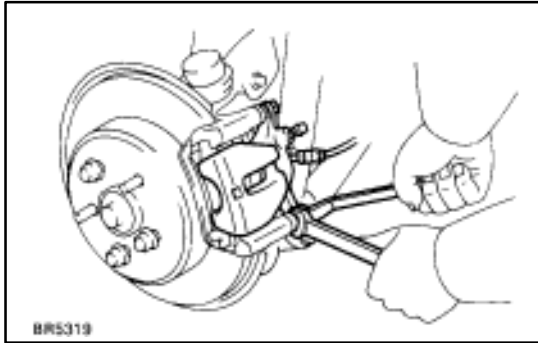

2. REMOVE CYLINDER

- (a) Hold the sliding pin and loosen the two installation bolts.
- (b) Remove the two installation bolts.
- (c) Remove the cylinder from the torque plate.

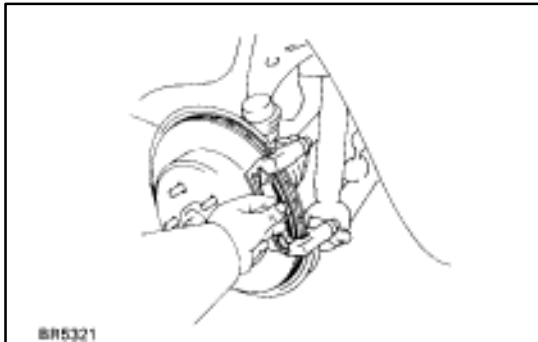

3. REMOVE FOLLOWING PARTS:

- (a) Two anti-squeal springs
- (b) Two brake pads

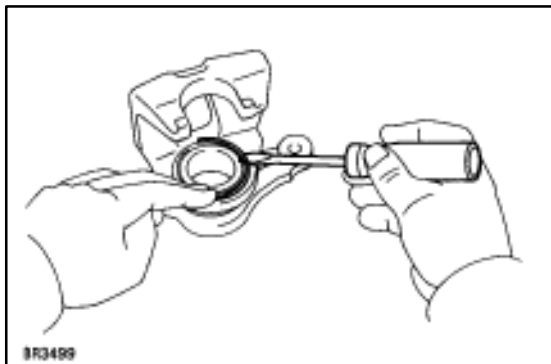

DISASSEMBLY OF CYLINDER

(See page [BR-27](#))

1. REMOVE CYLINDER BOOT SET RING AND CYLINDER BOOT

Using a screwdriver, remove the cylinder boot set ring and cylinder boot from the cylinder.

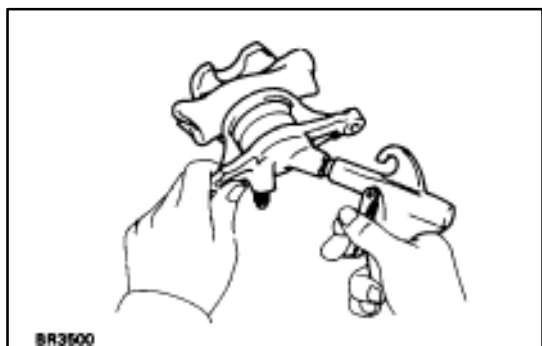

2. REMOVE PISTON

(a) Place a piece of cloth or similar article between the piston and the cylinder.

(b) Use compressed air to remove the piston from the cylinder.

CAUTION: Do not place your fingers in front of the piston when using compressed air.

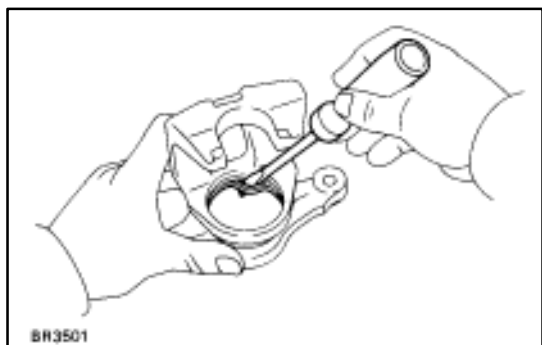

3. REMOVE PISTON SEAL

Using a screwdriver, remove the piston seal from the cylinder.

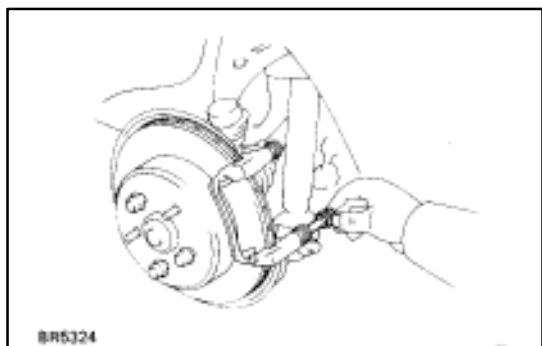

4. REMOVE SLIDING PINS AND DUST BOOTS

(a) Remove the two sliding pins from the torque plate.

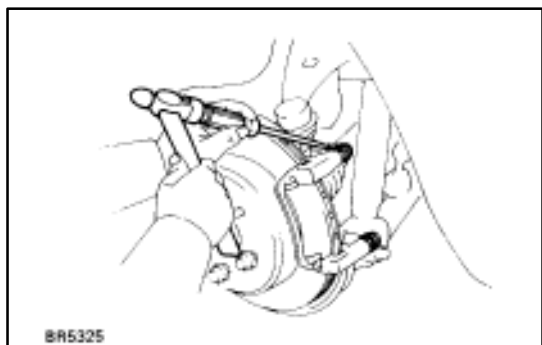

(b) Using a chisel and hammer, tap out the two dust boots.

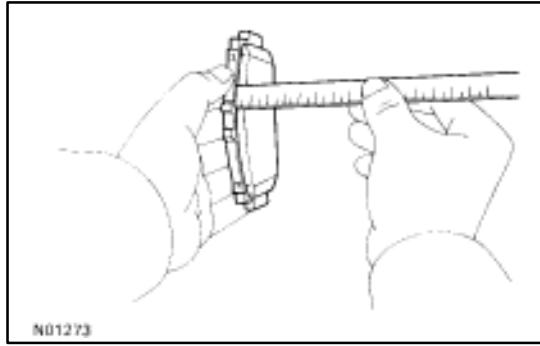

INSPECTION AND REPAIR OF REAR BRAKE COMPONENTS

1. MEASURE PAD LINING THICKNESS

Using a ruler, measure the pad lining thickness.

Standard thickness: 10.0 mm (0.394 in.)

Minimum thickness: 1.0 mm (0.039 in.)

Replace the pad if the pad's thickness is at the minimum thickness or less, or if the pad has severely uneven wear.

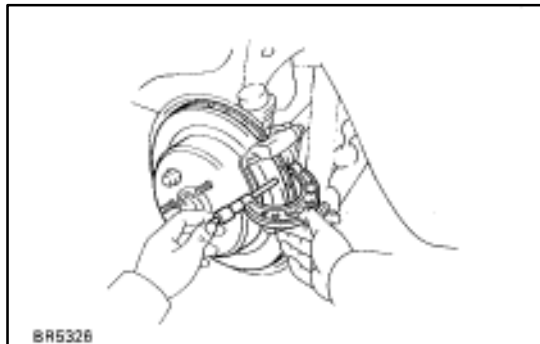

2. MEASURE ROTOR DISC THICKNESS

Using a micrometer, measure the rotor disc thickness.

Standard thickness: 16 mm (0.630 in.)

Minimum thickness: 15 mm (0.591 in.)

Replace the rotor disc if the thickness of the rotor disc is at the minimum thickness or less. Replace the rotor disc or grind it on a lathe if it is scored or is worn unevenly.

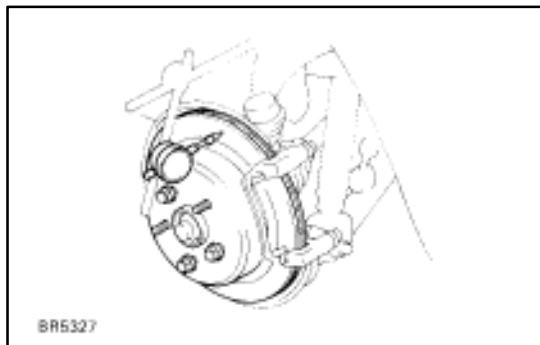

3. MEASURE ROTOR DISC RUNOUT

Using a dial indicator, measure the rotor disc runout at a position 10 mm (0.39 in.) from the outside edge.

Maximum disc runout: 0.05 mm (0.0020 in.)

If the rotor disc's runout is at the maximum value or greater, check the bearing play in the axial direction and check the axle hub runout (See page SA-50). If the bearing play and axle hub runout are not abnormal, adjust the rotor disc runout.

4. IF NECESSARY, ADJUST ROTOR DISC RUNOUT

(a) Remove the torque plate from the axle carrier.

(b) Remove the hub nuts of the temporarily installed disc and pull off the rotor disc.

(c) Install the rotor disc and measure the disc runout, then shift the rotor disc one fifth of a turn and measure the disc runout. Similarly measure the runout at each position, and select the position where the runout is minimum.

(d) In this position, if the runout is within specification, install the torque plate and torque the mounting bolts.

Torque: 104 N·m (1,065 kgf·cm, 77 ft·lbf)

(e) If not within specification, replace the rotor disc, and repeat (c) and (d).

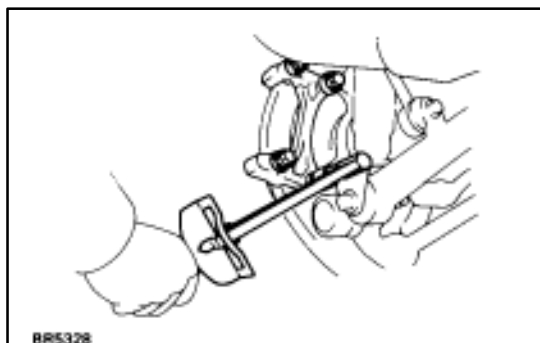

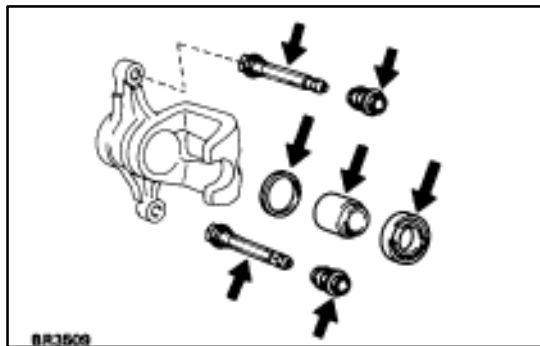

ASSEMBLY OF CYLINDER

(See page [BR-27](#))

1. APPLY LITHIUM SOAP BASE GLYCOL GREASE TO PARTS INDICATED WITH ARROWS

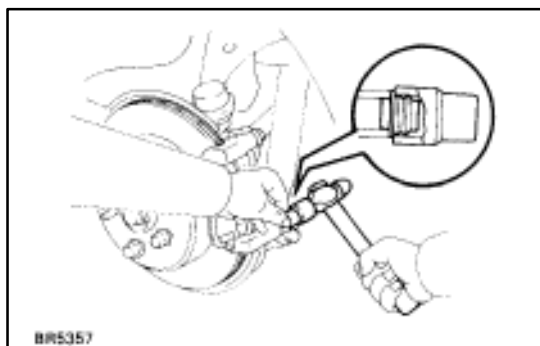

2. INSTALL DUST BOOTS AND SLIDING PINS

- (a) Using a 19 mm socket wrench and hammer, tap in two new dust boots into the torque plate.
- (b) Confirm that the metal plate portion of the dust boot fits snugly in the torque plate.

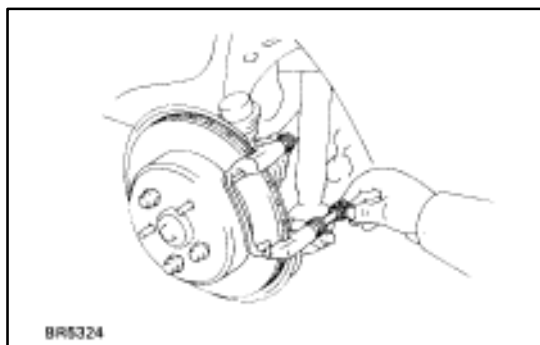

- (c) Insert two sliding pins into the torque plate.
NOTICE: Insert the sliding pin with the sliding bushing into the bottom side.

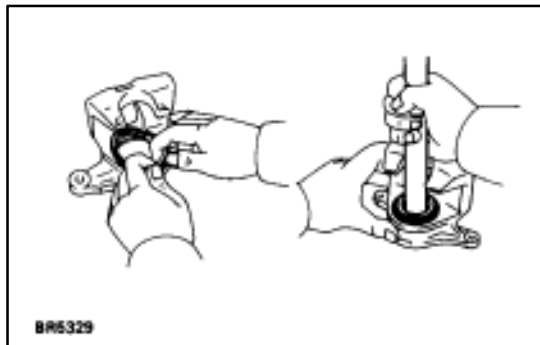

3. INSTALL PISTON SEAL AND PISTON IN CYLINDER

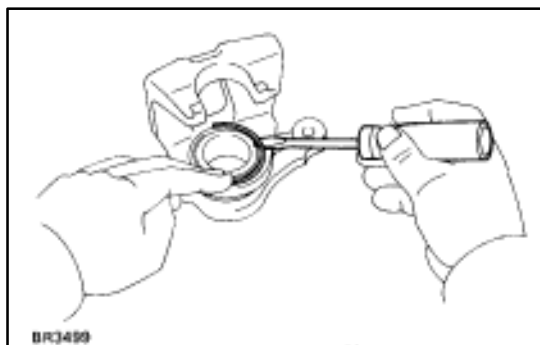

4. INSTALL CYLINDER BOOT AND CYLINDER BOOT SET RING

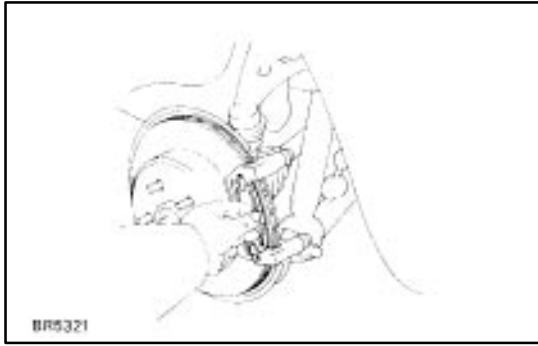

INSTALLATION OF CYLINDER

(See page [BR-27](#))

1. INSTALL FOLLOWING PARTS:

- (a) Two brake pads
- (b) Two anti-squeal springs

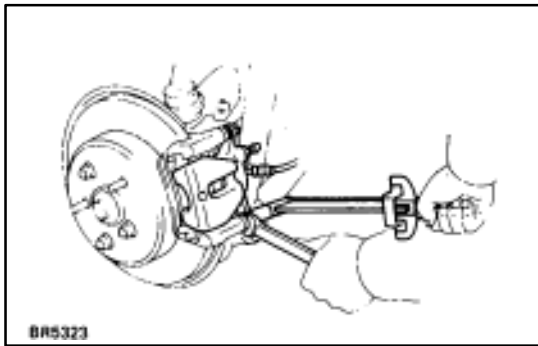

2. INSTALL CYLINDER

- (a) Temporarily install the cylinder on the torque plate with two installation bolts.
- (b) Hold the sliding pin and torque the installation bolts.

Torque: 34 N·m (350 kgf·cm, 25 ft·lbf)

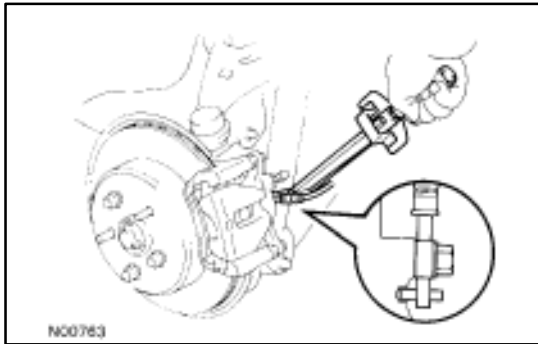

3. CONNECT FLEXIBLE HOSE

Install the flexible hose on the brake cylinder with two new gaskets.

Torque: 30 N·m (310 kgf·cm, 22 ft·lbf)

HINT: Insert the flexible hose lock securely in the lock hole in the brake cylinder.

4. FILL BRAKE RESERVOIR WITH BRAKE FLUID AND BLEED BRAKE SYSTEM

(See page [BR-6](#))

5. CHECK FOR LEAKS