

Part Number: PT938-48161

Kit Contents

Item #	Quantity Req'd.	Description
1	1	Running Board Assembly, LH
2	1	Running Board Assembly, RH
3	1	Hardware Pack

Hardware Bag Contents

Item #	Quantity Req'd.	Description
1	24	M6 X 1 Rivnut
2	26	M6 X 1 SEMS Bolt
3	2	M6 X 1 Wakai In-pull Nut
4	2	M6 Square Washer
5	2	Push-Pin Panel Fastener
6	14	Attachment Cover
7	2	Attachment Cover Small

Additional Items Required For Installation

Item #	Quantity Req'd.	Description

Conflicts

Mudguards cannot be installed after running boards
--

Recommended Tools

Personal & Vehicle Protection	Notes
Safety Glasses	
Cut Resistant Gloves	
Special Tools	Notes
Installation Tools	Notes
AVK 5500 Rivnut Gun	M6 X 1 Mandrill
Torque Wrench (1/4")	Range of 2.7 – 27 N-m
Ratchet and Socket	10mm
90 Degree Ratchet	#3 Philips Head Bit
Plastic Pry Tool	
Special Chemicals	Notes

General Applicability

All 2016 & new RX 350/450h models







Recommended Sequence of Application

Item #	Accessory
1	Mudguards
2	Running Boards

Vehicle Service Parts (may be required for reassembly)

Item #	Quantity Req'd.	Description
1		
2		
3		

Legend

	STOP: Damage to the vehicle may occur. Do not proceed until process has been complied with.
	OPERATOR SAFETY: Use caution to avoid risk of injury.
	CAUTION: A process that must be carefully observed in order to reduce the risk of damage to the accessory/vehicle and to ensure a quality installation.
	TOOLS & EQUIPMENT: Used in Figures calls out the specific tools and equipment recommended for this process.
	REVISION MARK: This mark highlights a change in installation with respect to previous issue.
	SAFETY TORQUE: This mark indicates that torque is related to safety.

Care must be taken when installing this accessory to ensure damage does not occur to the vehicle. The installation of this accessory should follow approved guidelines to ensure a quality installation.

These guidelines can be found in the "Accessory Installation Practices" document. This document covers such items as:

- Vehicle Protection (use of covers and blankets, cleaning chemicals, etc.).
- Safety (eye protection, rechecking torque procedure, etc.).
- Vehicle Disassembly/Reassembly (panel removal, part storage, etc.).
- Electrical Component Disassembly/Reassembly (battery disconnection, connector removal, etc.).

Please see your Lexus dealer for a copy of this document.

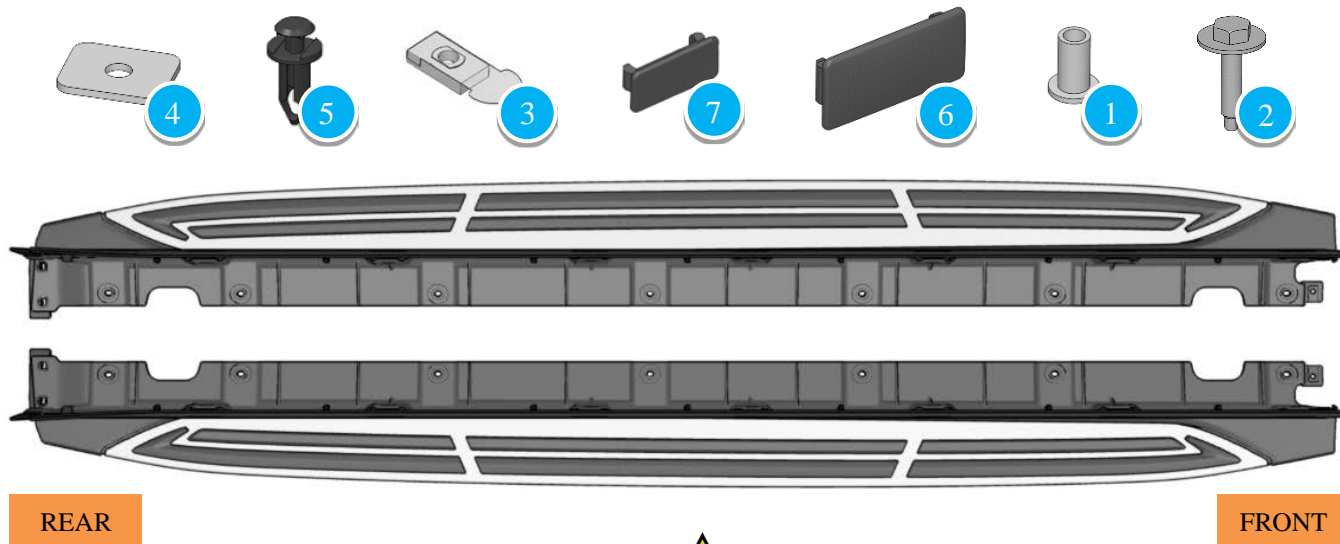

NOTE: Refer to the **Integration with Existing Mudguard** section on Page 12 if mudguards are to be installed with the running

1. Prepare the Vehicle.

- STOP** (a) Ensure the vehicle is clean prior to the running board installation.
- (b) Open all vehicle doors.
- (c) Lift the vehicle.

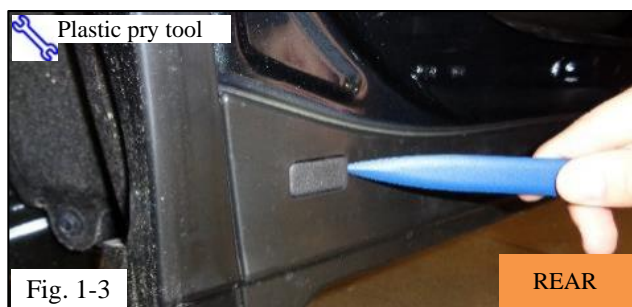
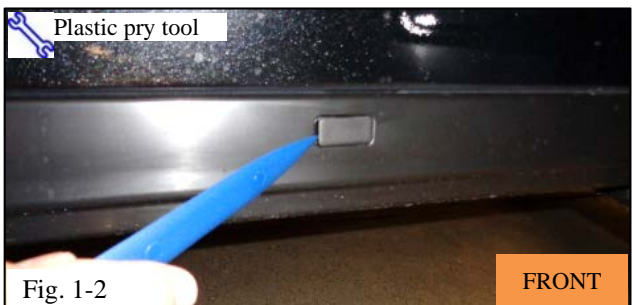
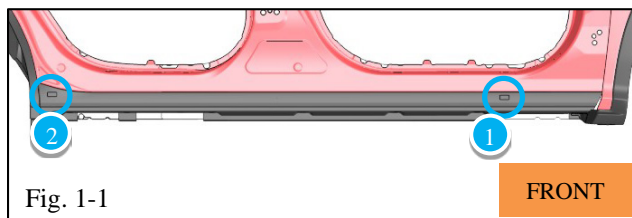

- (d) Use a plastic prying tool to remove the front and rear attachment covers (Fig. 1-1, Fig. 1-2 & Fig. 1-3).
- (e) Discard both front and rear attachment covers.

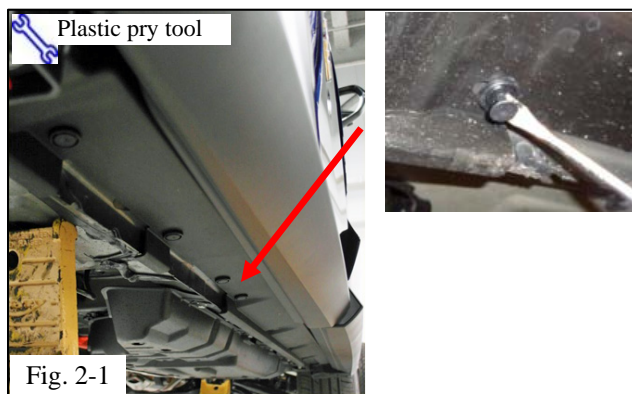

2. Remove the OE Rocker Cladding Push-Pins.

- (a) Remove the 7 push-pins along the bottom of the rocker cladding (Fig. 2-1). Discard all the push-pins.

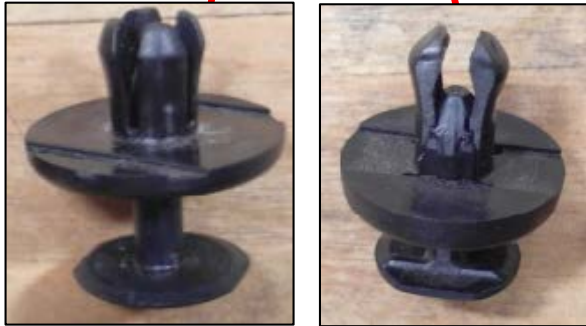
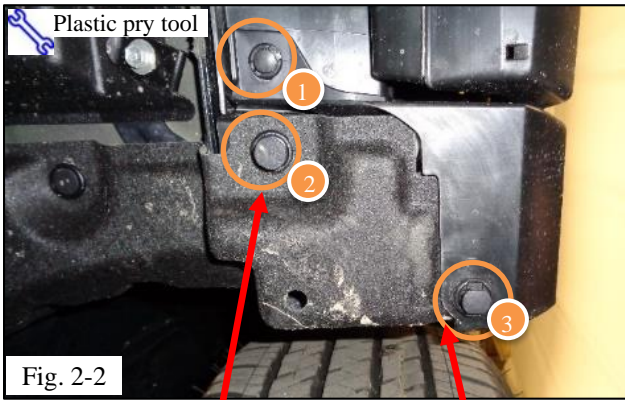

(b) At the front, remove push-pin ① securing the front fender to the rocker cladding (Fig. 2-2). Discard the push-pin.

⚠ (c) Remove push-pin ② holding the wheel well liner (Fig. 2-2). Retain the push-pin for reinstallation.

⚠ (d) Remove push-pin ③ securing the front fender flare (Fig. 2-2). Retain the push-pin for reinstallation.

3. Detach the Front Fender Flare.

(a) Gently pull and disengage two lower front fender flare clips from the vehicle body (Fig. 3-1).

⚠ **NOTE:** The fender flare clip may pop out of the fender flare and remain in the vehicle body. If this happens, remove it from the vehicle and place it back into position on the fender flare (Fig. 3-2).

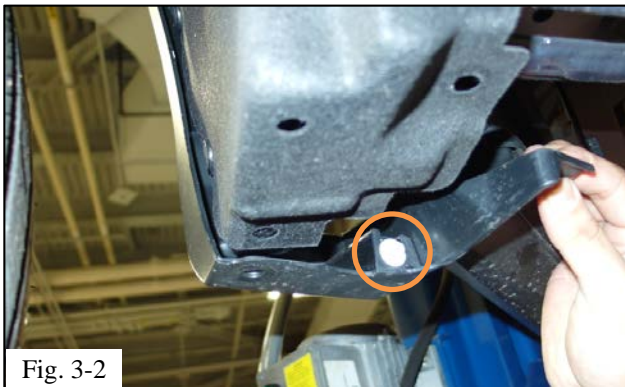

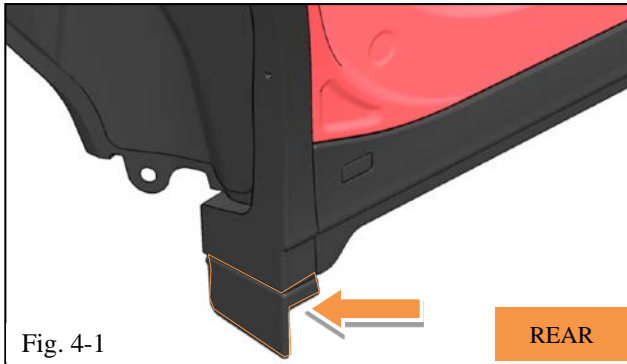

Fig. 4-1



Fig. 4-2

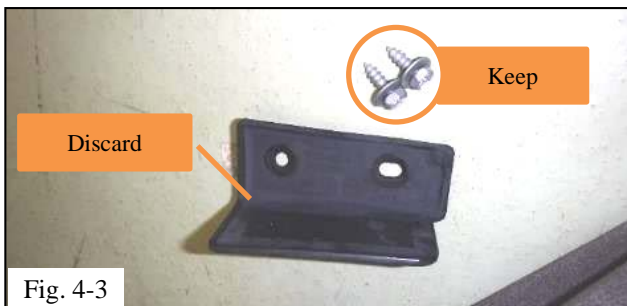



Fig. 4-3



Fig. 5-1

4. Remove the Rear Air Diffuser.

(a) Locate the air diffuser at the rear of the vehicle (Fig. 4-1).

 (b) Use a 10mm socket to unfasten the 2 screws holding the air diffuser (Fig. 4-2). Retain the screws for reinstallation.

(c) Remove and discard the air diffuser. (Fig. 4-3).

5. Detach the Rear Fender Flare.

 (a) Use a Philips screw driver to remove the 1st and 2nd screws from the bottom of the rear fender flare (Fig. 5-1). Retain these screws for reinstallation.

(b) Carefully pull the fender flare from the vehicle to gain access to the cladding.

 **NOTE:** The fender flare is fastened with tape to the vehicle; be careful not tear the tape underneath.



6. Remove the Screw from the OE Rocker Cladding.

-  (a) Use a Philips head driver to unfasten the rear screw securing the rocker cladding (Fig. 6-1). Retain the screw for reinstallation.

- (b) Unfasten the screw at the front of the vehicle (Fig. 6-2). Discard the screw.

7. Remove the OE Rocker Cladding.

- (a) Carefully move the rear fender flare out of the way to remove rocker cladding.
- (b) Starting from the rear, use a plastic pry tool to gain access to the rocker cladding and disengage the rocker cladding clips from the vehicle by hand (Fig. 7-1).



(c) Lower the rear of the rocker cladding slightly and gently pull it rearward to remove the cladding from the vehicle. Discard the rocker cladding (Fig.7-2).



(d) Ensure that all 6 fastening clips on the vehicle are removed from the vehicle rocker. (Fig. 7-3).



(e) Use a plastic pry tool to disengage the plastic nut located at the front slot of the rocker panel (Fig. 7-4). Discard the plastic nut only.

⚠ NOTE: Leave the rear nut in its current inserted position.

8. Insert the Wakai In-Pull Nut.

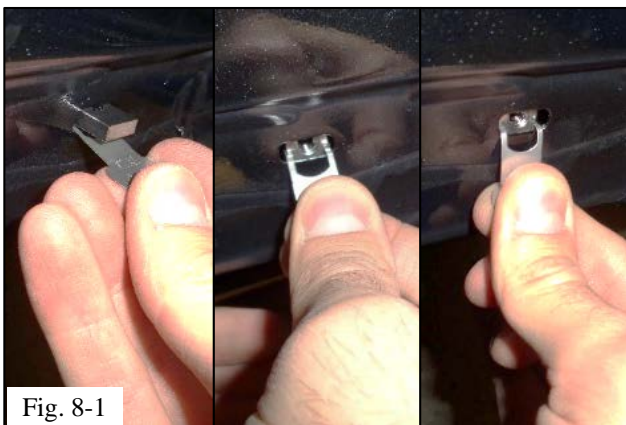

(a) With Wakai nut metal tab facing down, insert it into the slot (from which the plastic nut was removed in Step 7(e)) at the front of the rocker panel (Fig. 8-1).

⚠ NOTE: Make sure the metal tab is facing down. If it is inserted incorrectly, it will be extremely difficult to remove!

⚠ (b) Use a piece of masking tape to secure the Wakai tab to the rocker panel.

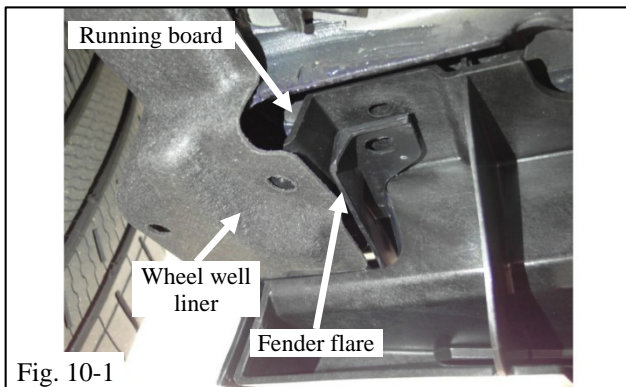
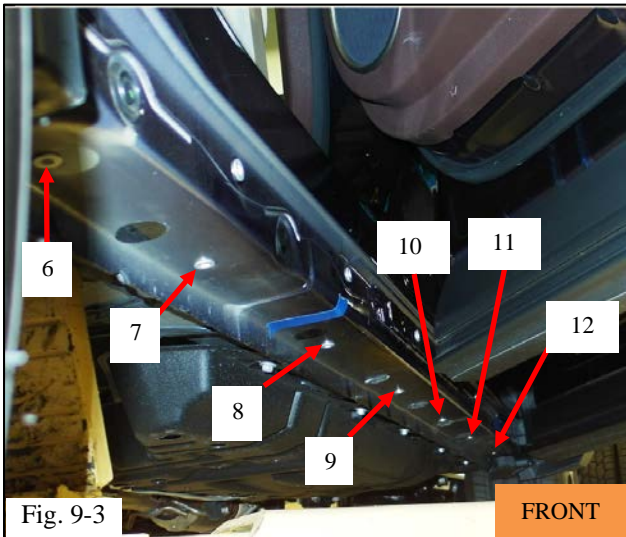
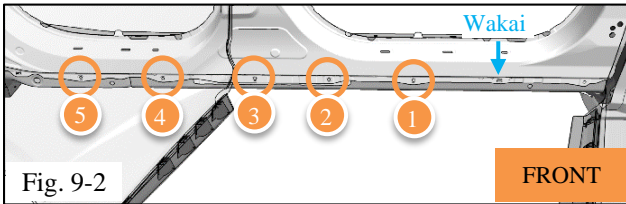
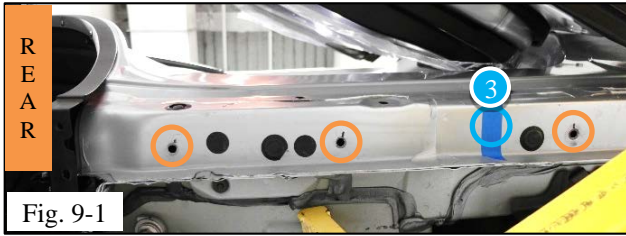

9. Install Rivnuts Into the Rocker Panel.

- (a) Use masking tape to cover the 3rd hole from the rear on the **underside** of the rocker panel. See position ③ (Fig. 9-1).

⚠ NOTE: The 3rd hole from the rear is not used.

- (b) Install 5 Rivnuts on the rocker panel facing outwards (Fig. 9-2).

- (c) Install 7 Rivnuts on the **underside** of the rocker (Fig. 9-3).

- (d) Remove the masking tape.

10. Install the Running Board.

⚠ NOTE: Refer to the **Integration with Existing Mudguard** section on Page 12 if mudguards are to be installed with the running boards.

- (a) Position the running board to allow the insertion of the front fender flare through the opening in the front of the running board (Fig. 10-1).

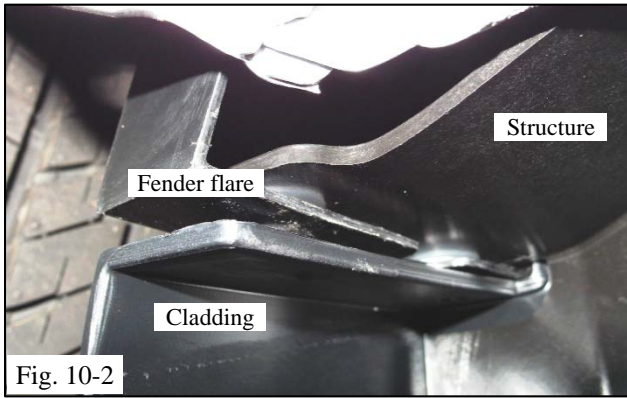

(b) Push the running board forward and install the rear of the running board to the vehicle. Wedge the rear fender flare in between the composite structure and the cladding of the running board (Fig. 10-2).

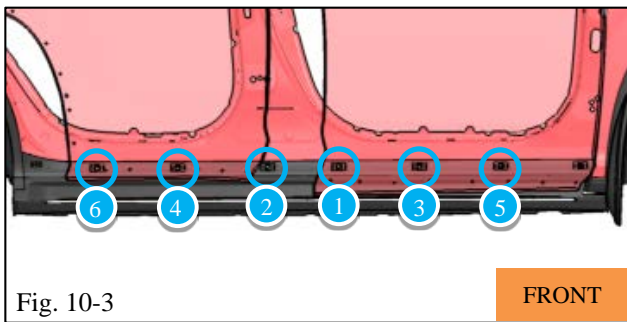

(c) Insert an M6 bolt at the center hole (location 1). Hand start the bolt (3 to 4 threads) to hold the board in place (Fig. 10-3).

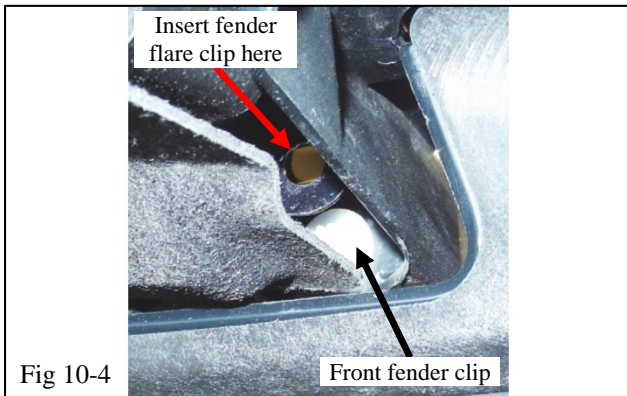

(d) Reinstall the front fender flare by first attaching the bottom clip to the vehicle, then the other 2 remaining clips (Fig. 10-4).

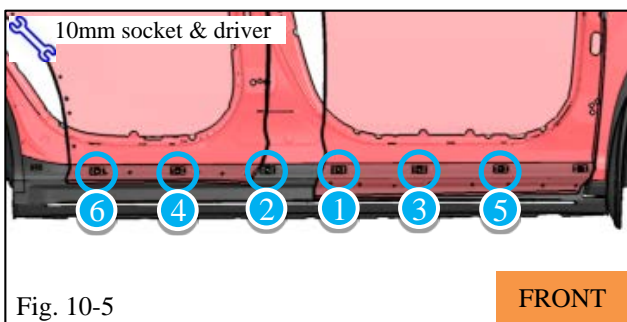

(e) Hand start the remaining 5 M6 bolts. Tighten and torque each to 7 N-m in the sequence shown in Fig. 10-5.

 Torque: 7 N-m (62 in-lbf)

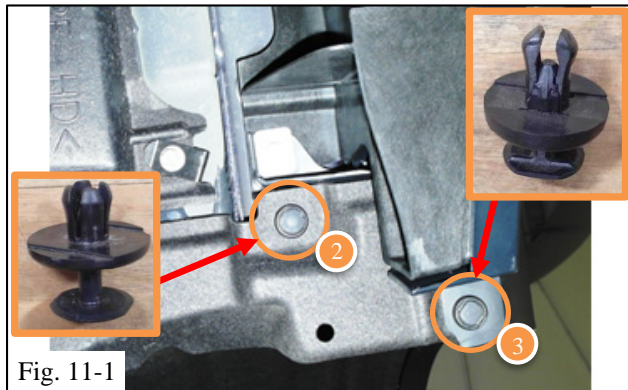
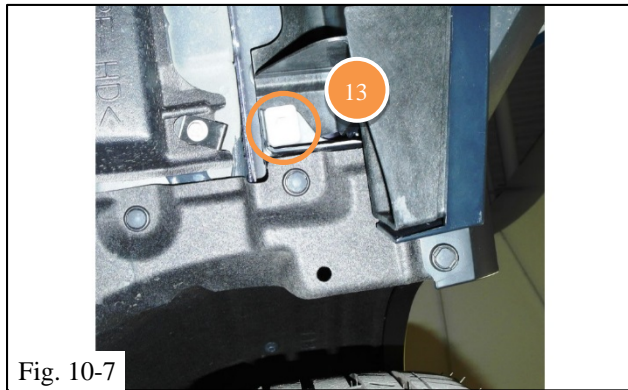
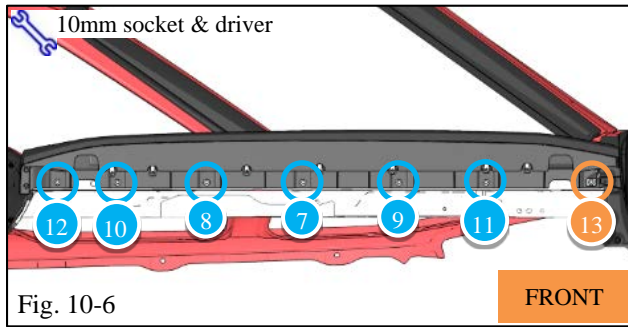

- (f) Hand start bolts into locations 7 to 12 and a bolt with a square washer into location 13 on the underside in the sequence shown in Fig. 10-6. Torque to 7 N-m.

S Torque: 7 N-m (62 in -lbf)

! NOTE: Location ⑬ requires 1 square washer (Fig. 10-7).

- (g) Re-torque all 13 fasteners.

! NOTE: Complete the torque audit sheet within 5 minutes of re-torquing the hardware.

11. Reinstall the Front Fender Flare and Liner.

- (a) Reinstall push-pin 2 fastening the wheel liner to the running board (Fig. 11-1).
- (b) Reinsert push-pin 3 securing the front fender flare to the vehicle body (Fig. 11-1).

- (c) Insert the push-pin fastener (included in the hardware pack) in the front hole position (Fig. 11-2).

12. Reinstall the Rear Fender Flare.



- (a) Reinstall the 2 screws at the rear fender flare (Fig. 12-1).



- (b) Reinstall the screws mounting the rear fender flare (Fig. 12-2).



- (c) Reinstall the screw at the rear of the cladding (Fig. 12-3).



- (d) Snap in the small attachment cover at the rear (Fig. 12-4).



- (e) Snap in the remaining 7 large attachment covers (Fig. 12-5).

13. Install the Remaining Running Board.

- (a) Repeat Steps 1 to 12 on the other side of the vehicle.
- (b) Close the doors on the vehicle.

❖ Integration With Existing Mudguard.

- (a) On vehicles with pre-existing mudguards, remove the screw securing the mudguard to the cladding (Fig. 1).

⚠ NOTE: Only remove the circled screw!
Removing other fasteners will create interference with the running board.

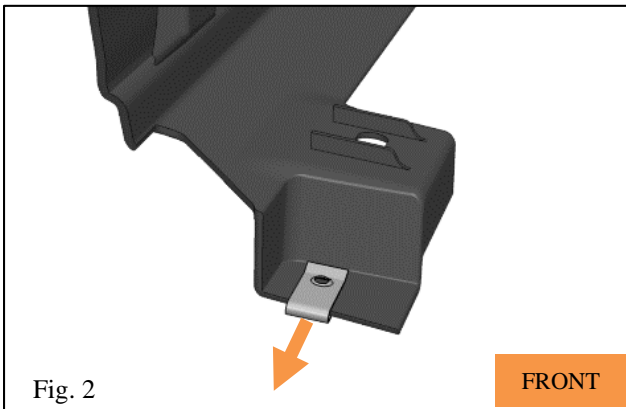
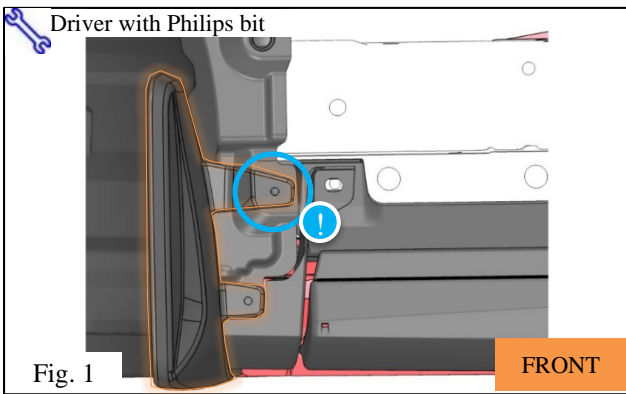

- (b) Remove the U-clip mounted at the front of the cladding (Fig. 2).

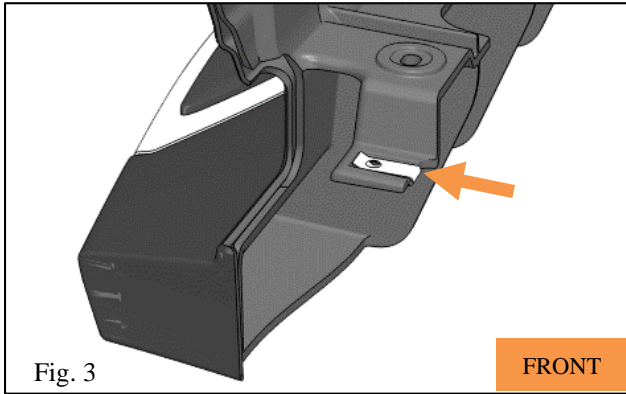

(c) Insert this U-clip, with the curved edge toward the inside of the vehicle, into position at the front of the running board (Fig. 3).

⚠ NOTE: Execute this step prior to mounting the running board to the vehicle.

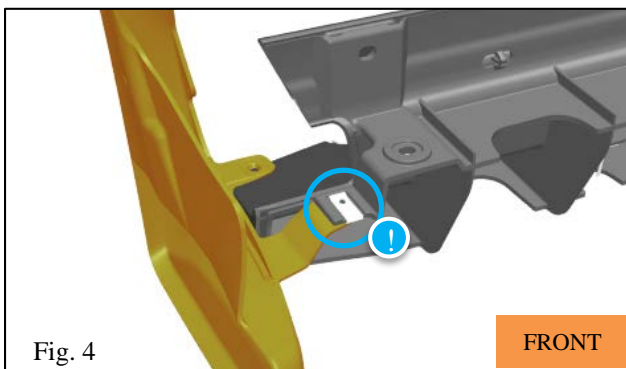

(d) After installing the running board, reinstall the screw to secure the mudguard to the running board (Fig. 4).

Checklist - these points **MUST** be checked to ensure a quality installation.

<u>Check:</u>	<u>Look For:</u>
<p><u>Accessory Function Checks</u></p> <p><input type="checkbox"/> Torque audit sheet</p> <p><input type="checkbox"/></p> <p><input type="checkbox"/></p>	<p>Torque audit sheet is complete.</p>
<p><u>Vehicle Function Checks</u></p> <p><input type="checkbox"/></p> <p><input type="checkbox"/></p> <p><input type="checkbox"/></p>	
<p><u>Vehicle Appearance Check</u></p> <p><input type="checkbox"/> After accessory installation and removal of protective cover(s), perform a visual inspection.</p>	<p>Ensure no damage (including scuffs and scratches) was caused during the installation process. (For PPO installations, refer to TMS Accessory Quality Shipping Standard.)</p>