

**Part Number: Tuner Assy 86180-0W031
Mounting Kit 86100-0W160**

NOTE: Part number of this accessory may not be the same as the part number shown.

Tuner Assy Kit Contents (86180-0W031)

Item #	Quantity Reqd.	Description
1	1	TUNER ASSY, STEREO COMPONENT

Mounting Kit Contents (86100-0W160)

Item #	Quantity Reqd.	Description
1	1	Wire, To Radio Installation
2	1	Bracket, Radio Receiver A
3	1	Bracket, Radio Receiver B
4	1	Antenna

Hardware Bag Contents 1 (86100-0W160)

Item #	Quantity Reqd.	Description
1	3	Cushion Tape A (50mm × 100mm × 3mm (thick))
2	1	Cushion Tape B (50mm × 100mm × 6mm (thick))
3	14	Tie Wrap

Hardware Bag Contents 2 (86100-0W160)

Item #	Quantity Reqd.	Description
1	4	Screw (M5 × L8)
2	2	Bolt (M6 × L16)
3	1	Nut (M6 · Flange)

Hardware Bag Contents 3 (86100-0W160)

Item #	Quantity Reqd.	Description
1	1	Template
2	3	Nylon Tape (30mm × 30mm)
3	7	Tie Wrap
4	1	Protective Sheet (20mm × 40mm)

Additional Items Required For Installation

Item #	Quantity Reqd.	Description

Conflicts

iPod Interface, Sirius Satellite Radio
--

Recommended Tools

Personal & Vehicle Protection	Notes
Vehicle Protection	Clean Cloths, Part Boxes
Special Tools	Notes
None	
Installation Tools	Notes
Panel Clip Removal Tool	e.g. Toyota SST P/N:- 00002-06002-01
Socket	10mm, 12mm, 14mm
Screwdriver	Phillips, #2
Wrench	Open End, 10mm, 12mm 14mm
Torque Wrench	36 lbf · in (battery cable) 27 lbf · ft (rear seat)
Extension	
Side Cutter	
Masking tape	
Special Chemicals	Notes
Cleaner	3M Prep Solvent 70

General Applicability

--

Recommended Sequence of Application







Item #	Accessory

*Mandatory

Vehicle Service Parts (may be required for reassembly)

Item #	Quantity Reqd.	Description

Legend

	STOP: Damage to the vehicle may occur. Do not proceed until process has been complied with.
	OPERATOR SAFETY: Use caution to avoid risk of injury.
	CAUTION: A process that must be carefully observed in order to reduce the risk of damage to the accessory/vehicle and to ensure a quality installation.
	TOOLS & EQUIPMENT: Used in Figures calls out the specific tools and equipment recommended for this process.
	REVISION MARK: This mark highlights a change in installation with respect to previous issue.
	SAFETY TORQUE: This mark indicates that torque is related to safety.

Parts Description of Tuner Assy (86180-0W030)

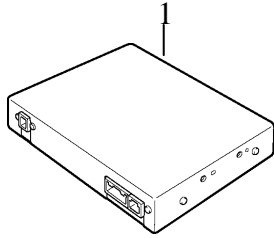

Item #	Parts Name	Parts No.	Qty
1	TUNER ASSY, STEREO COMPONENT ★	86180-0W030	1

★ In the installation instructions and figures, this is referred to as “Tuner”.

SEWELL

Parts Description of Mounting Kit (86100-0W160)

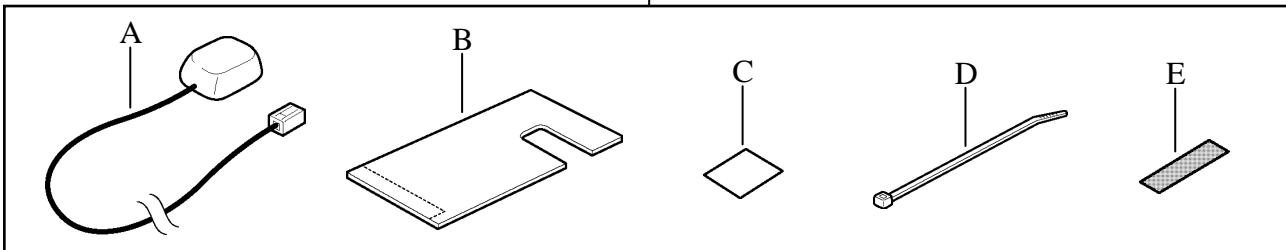
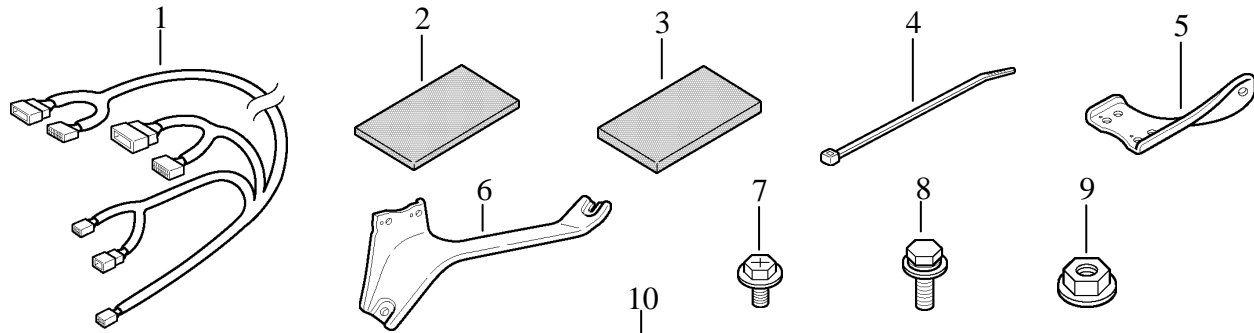

Item #	Parts Name	Parts No.	Qty
1	Wire, To Radio Installation ★1	82372-0W080	1
2	Cushion Tape A (50mm×100mm×t3mm)	—	3
3	Cushion Tape B (50mm×100mm×t6mm)	—	1
4	Tie Wrap	—	14
5	Bracket, Radio Receiver A ★2	86215-0W140	1
6	Bracket, Radio Receiver B ★3	86215-0W150	1
7	Screw (M5×L8)	90153-50010	4
8	Bolt (M6×L16)	90119-A0038	2
9	Nut (M6 · Flange)	90080-17185	1
10	A Antenna	86960-0W020 ANTENNA ASSY, SATELLITE RADIO	1
	B Template		1
	C Nylon Tape (30mm×30mm)		3
	D Tie Wrap		7
	E Protective Sheet (20mm×40mm)		1

- ★ 1 In the installation instructions and figures, this is referred to as “Tuner Cable”.
- ★ 2 In the installation instructions and figures, this is referred to as “Tuner Bracket A”.
- ★ 3 In the installation instructions and figures, this is referred to as “Tuner Bracket B”.

Care must be taken when installing this accessory to ensure damage does not occur to the vehicle. The installation of this accessory should follow approved guidelines to ensure a quality installation.

These guidelines can be found in the "Accessory Installation Practices" document.

This document covers such items as:-

- Vehicle Protection (use of covers and blankets, cleaning chemicals, etc.).
- Safety (eye protection, rechecking torque procedure, etc.).
- Vehicle Disassembly/Reassembly (panel removal, part storage, etc.).
- Electrical Component Disassembly/Reassembly (battery disconnection, connector removal, etc.).

Please see your Lexus dealer for a copy of this document.

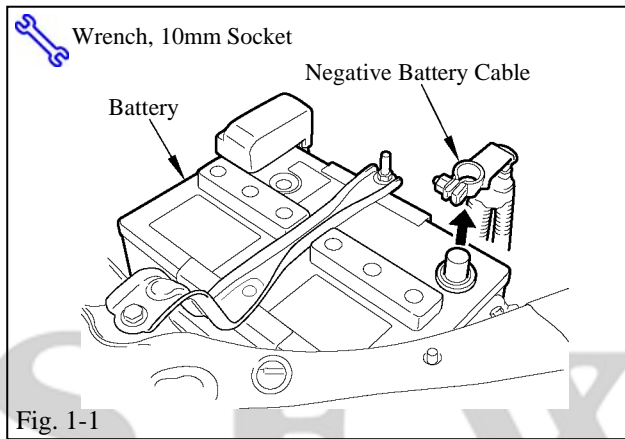

1. Vehicle Protection

- (a) Place front passenger seat in mid position.
- (b) Set emergency hand brake.
- (c) Remove the negative battery cable (Fig. 1-1).
 - (1) Protect the fender before starting.
 - (2) Do not touch the positive terminal with any tool when removing cable.
- (d) Cover front and middle seats, interior of vehicle and center console forward of shifter.
- (e) Wait 90 seconds before proceeding to disassemble vehicle.

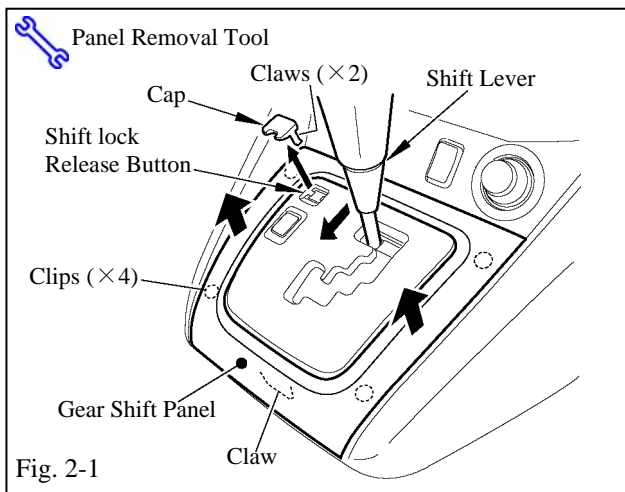

2. Disassembly of Vehicle

- STOP NOTE:** Place all removed parts on a protected surface.
- STOP NOTE:** When disconnecting wiring connectors do not pull on the wiring, pull on the connector only.
- (a) Remove the gearshift panel (Fig. 2-1).
 - NOTE:** The illustration shows a sequential shiftomatic vehicle, but the procedure is the same for a five-speed automatic model.
 - (1) Remove the cap of the release button
 - (2) Press the shift lock release button and move the shift lever to position S-D or 2-L.
 - (3) Pull gearshift panel in the direction of the arrow, and remove the clips and claws.

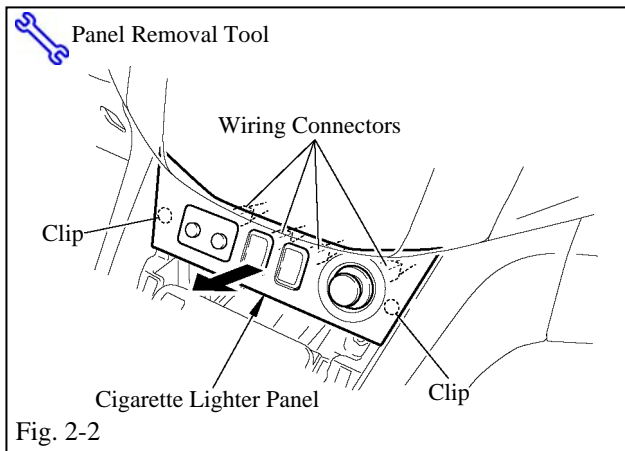

(b) Remove the cigarette lighter panel (Fig. 2-2).

NOTE: The illustration shows a vehicle equipped with a seat heater switch, headlamp wiper switch and height control switch, but the procedure is the same for other models.

- (1) Pull the panel in the direction of the arrow, and remove the clips.
- (2) Disconnect the wiring connector.

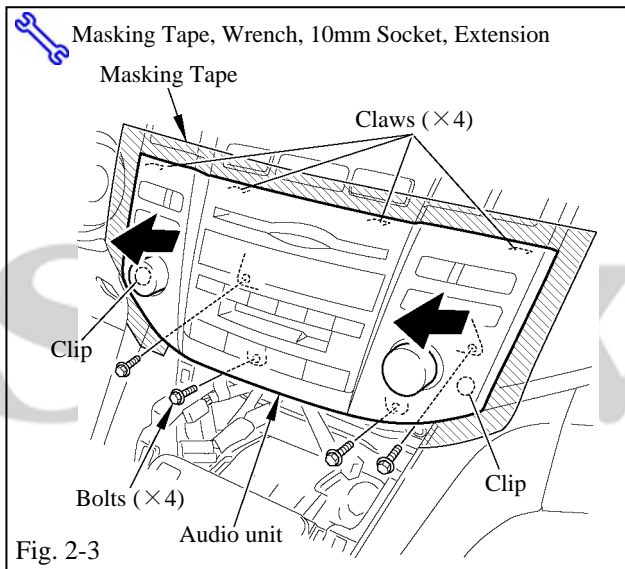

(c) Remove the audio unit.

NOTE: The illustration shows a vehicle equipped with Mark Levinson Audio, but the procedure is the same for other models.

- (1) Affix masking tape around the edge of the audio unit (the shaded area) to protect the unit from damage (Fig. 2-3).
- (2) Remove the mounting bolts (Fig. 2-3).

NOTE: When removing the unit, use magnetic tools, and avoid dropping bolts. It may be difficult to retrieve bolts dropped in some locations.

- (3) Pull the audio unit in the direction of the arrows, and disconnect the wiring connector (Fig. 2-3).

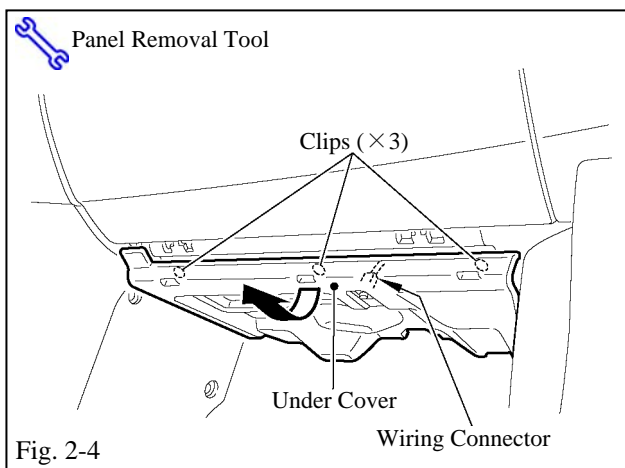

(d) Remove the under cover from beneath the glove box (Fig. 2-4).

- (1) Pull the cover in the direction of the arrow, and remove the clips.
- (2) Disconnect the wiring connector.

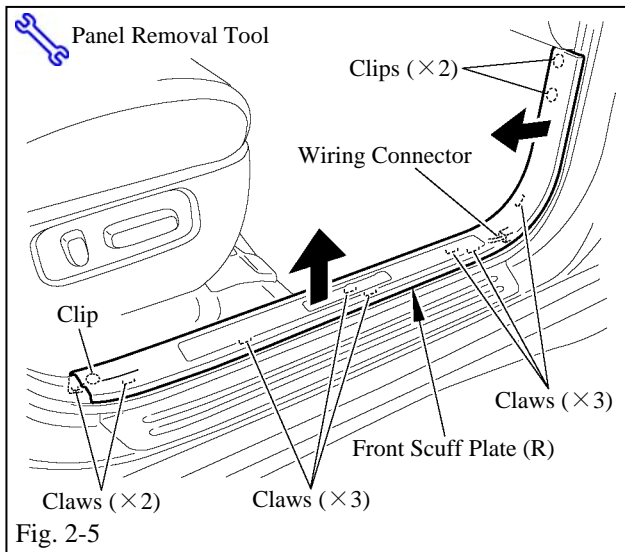

- (e) Remove the front scuff plate (R) (Fig. 2-5).
 - (1) Pull the plate in the direction of the arrow, and remove the clip and claw.
 - (2) Disconnect the wiring connector. (On vehicles with that equipment).

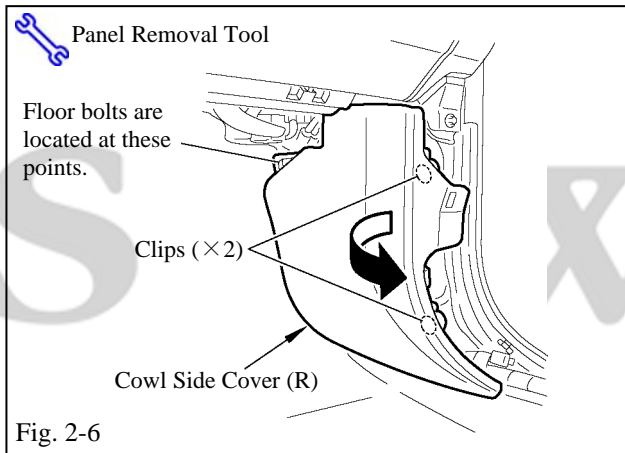

- (f) Remove the cowl side cover (R) (Fig. 2-6).
 - (1) Pull the cover in the direction of the arrow, and remove the clips.

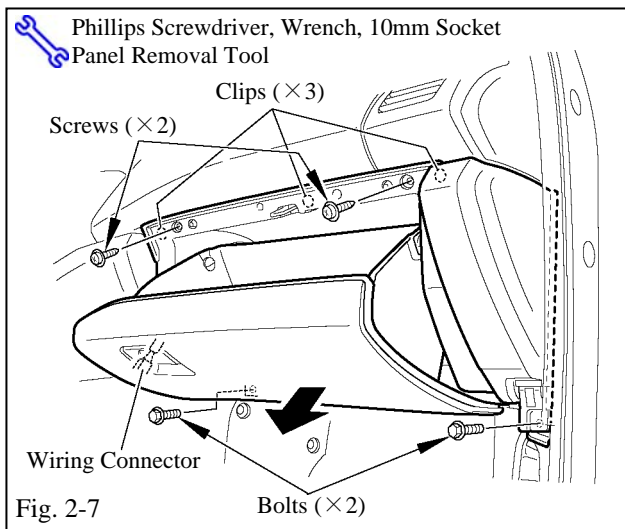

- (g) Remove the glove box (Fig. 2-7).
 - (1) Remove the screws and bolts.
 - (2) Pull the glove box out and remove the clips.
 - (3) Disconnect the wiring connector.

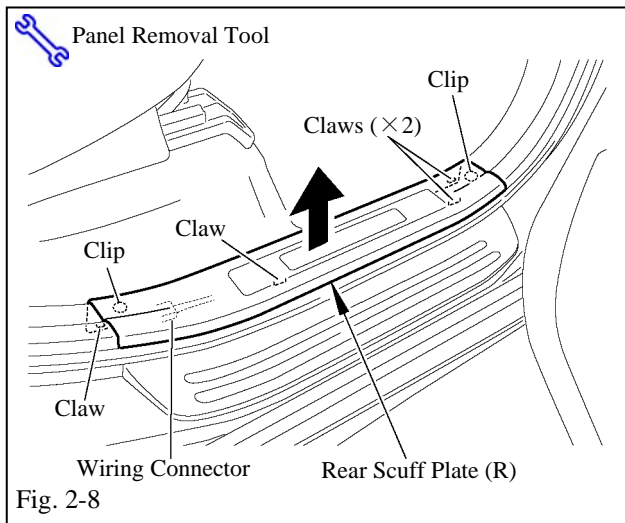

- (h) Remove the rear scuff plate (R) (Fig. 2-8).
 - (1) Pull the plate in the direction of the arrow, and detach the clips and claws.
 - (2) Disconnect the wiring connector. (On vehicles with that equipment).

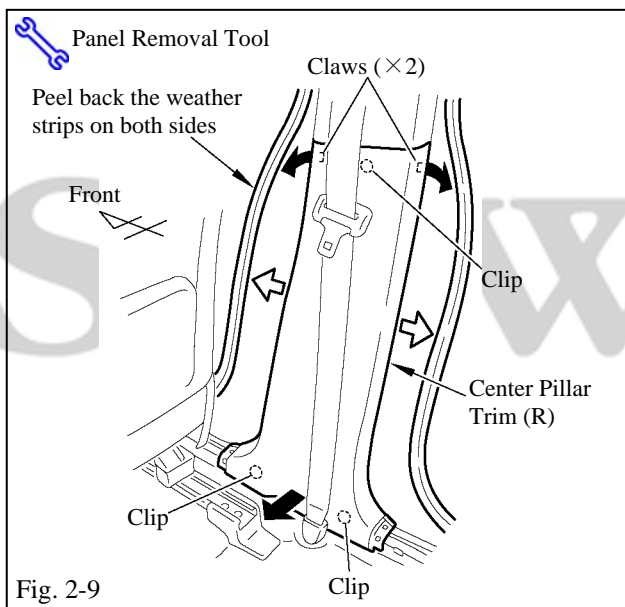

- (i) Remove the center pillar trim (R) (Fig.2-9).
 - (1) Peel back the front and rear weather strips.

NOTE : Take care to keep the sealant of the weather strip off the center pillar trim (R).

 - (2) Pull the trim in the arrowed directions, then detach the clips and claws.

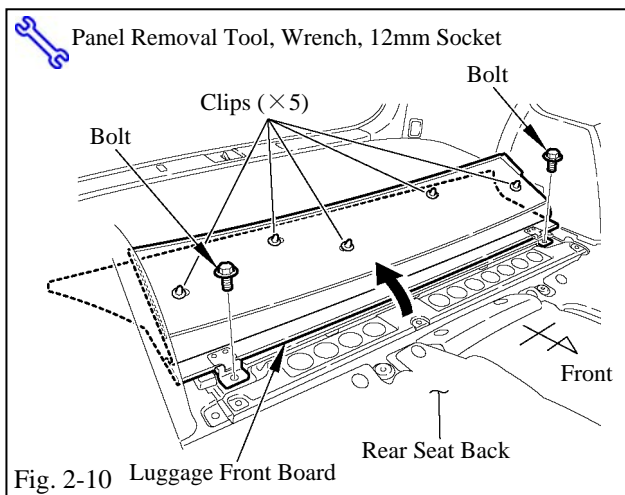

- (j) Remove the tonneau cover from the luggage compartment.
- (k) Remove the luggage compartment front board (Fig. 2-10).
 - (1) Pull the front of the board in the arrowed direction, and remove the clips.
 - (2) Remove the bolts.

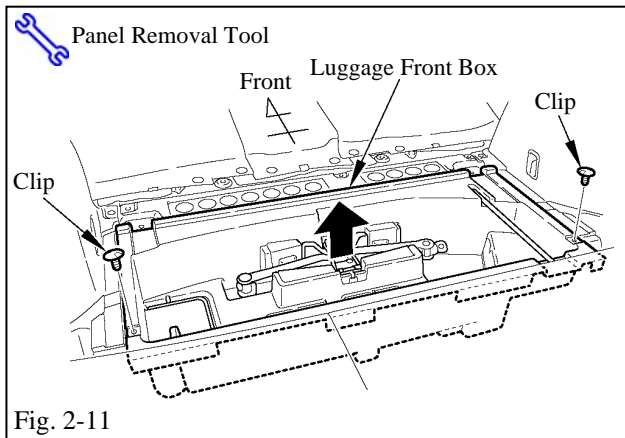

Fig. 2-11

- (l) Remove the luggage front box (Fig. 2-11).
- (1) Remove the clips.

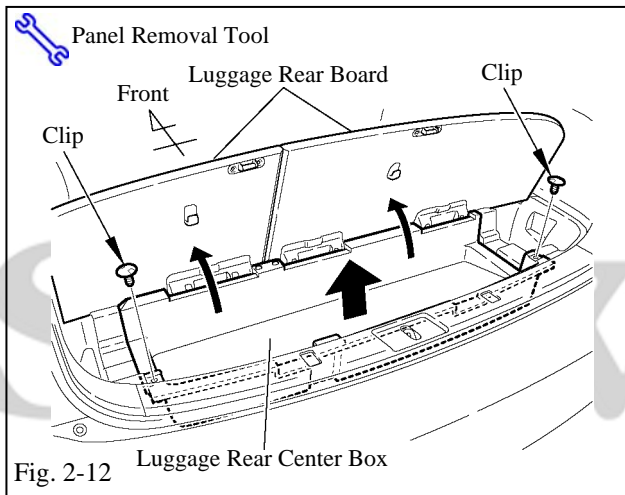

Fig. 2-12

- (m) Remove the luggage rear center box (Fig. 2-12).
- (1) Open the luggage rear board.
- (2) Detach the clips.

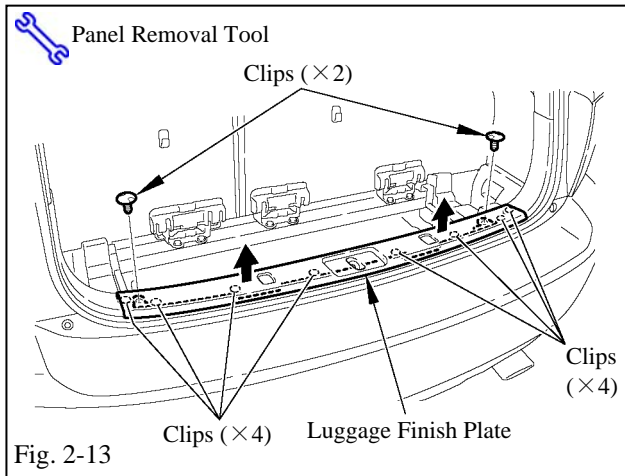
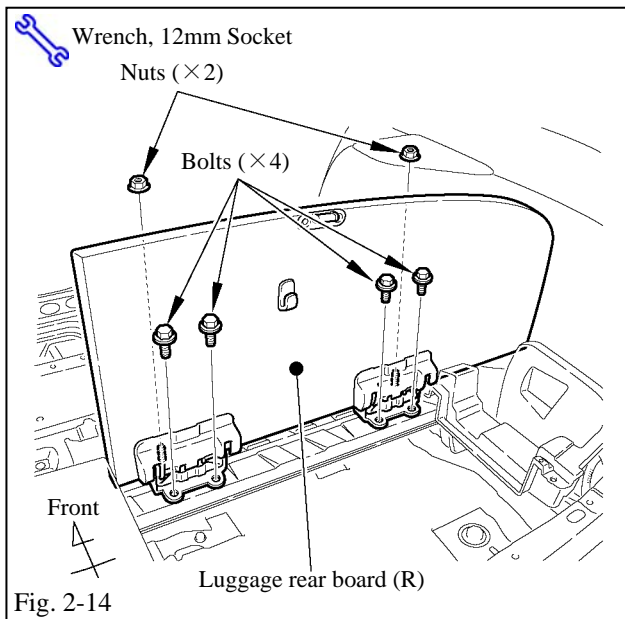

Fig. 2-13

- (n) Remove the luggage finish plate (Fig. 2-13).
- (1) Detach the clips.
- (2) Pull the plate in the direction of the arrows, and remove the clips.



(o) Remove the luggage rear board (R)
(Fig 2-14).

(1) Remove the bolts and nuts.

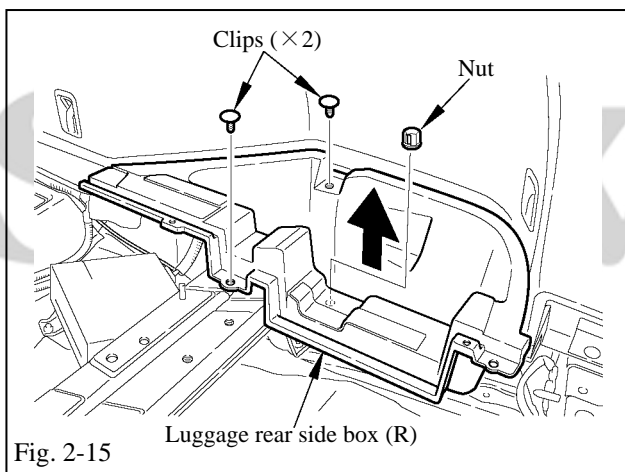

(p) Remove the luggage rear side box (R)
(Fig. 2-15).

(1) Remove the clips and nut.

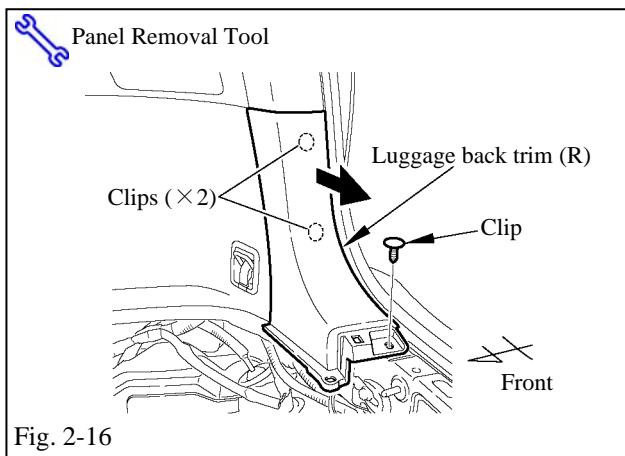

(q) Remove the luggage back trim (R)
(Fig. 2-16).

(1) Remove the clips.

(2) Pull the trim in the direction of the arrow,
and remove the clip.

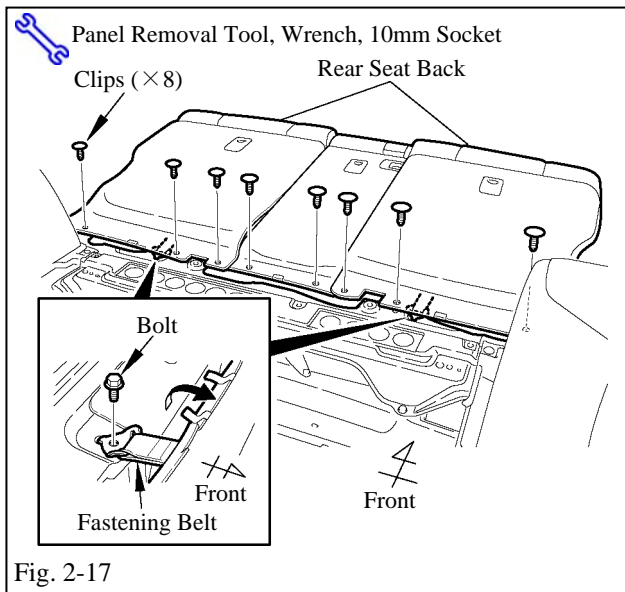

Fig. 2-17

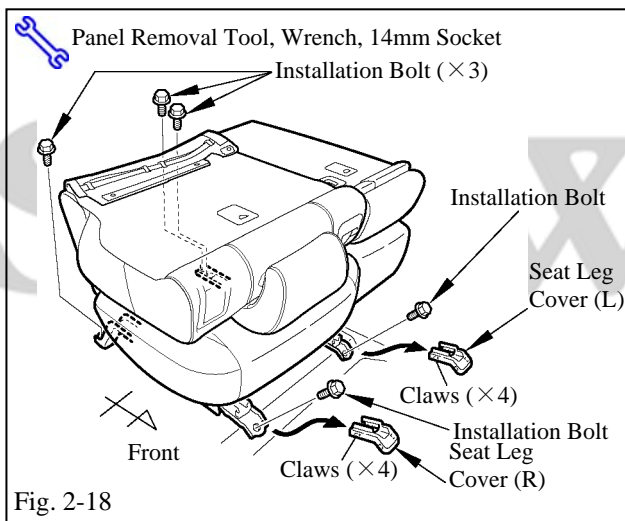

Fig. 2-18

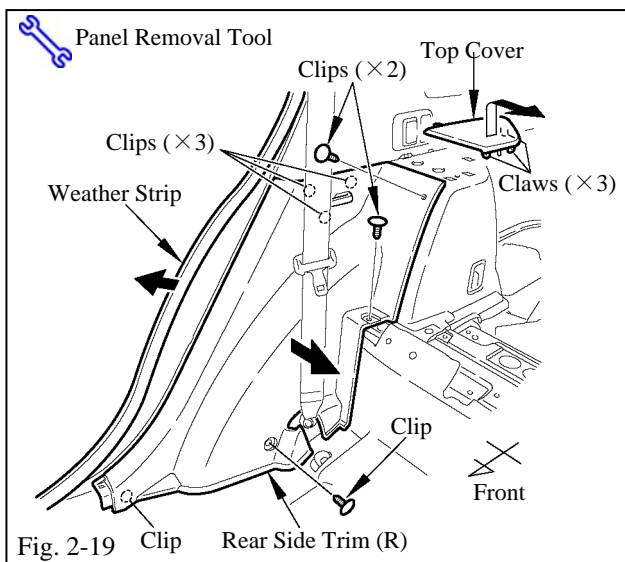

Fig. 2-19

(r) Remove the clips that hold down the carpet on the back of the rear seat back (Fig. 2-17).

(s) Remove the mounting bolts that hold the fastening belt for the rear seat back (Fig. 2-17).

(t) Remove the rear seat (R) (Fig. 2-18).

(1) Remove the front seat leg cover.

(2) Remove the front mounting bolts.

(3) Remove the rear mounting bolts

(u) Remove the rear side trim (R) (Fig. 2-19).

(1) Pull the top cover in the direction of the arrow to remove it.

(2) Peel back the weather strip.

(3) Remove the clips.

(4) Pull the trim in the direction shown by the arrows, and remove the clips.

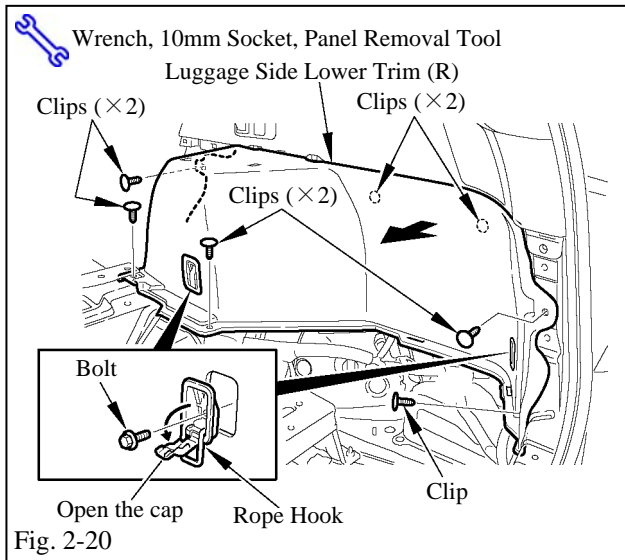

- (v) Remove the luggage side lower trim (R) (Fig. 2-20).
- (1) Remove the bolt, then remove the front rope hook.
- (2) Remove the bolt, then remove the rear rope hook.
- (3) Remove the clips.
- (4) Pull the trim in the direction shown by the arrows, and remove the clips.

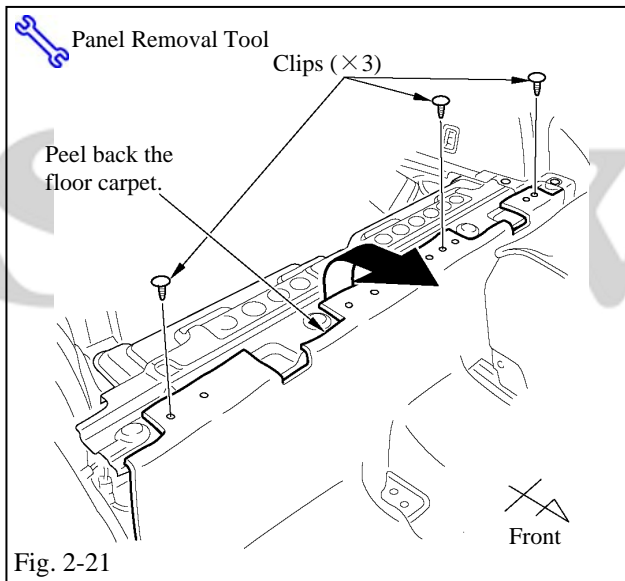

- (w) Remove the clips that hold the floor carpet (Fig. 2-21).

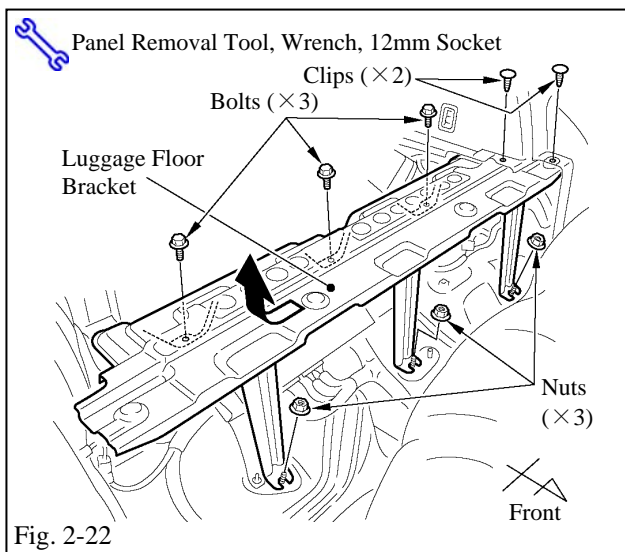

- (x) Remove the luggage floor bracket (Fig. 2-22).
- (1) Remove the last clips on the left.
- (2) Remove the nuts on the front side.
- (3) Remove the rear bolts.

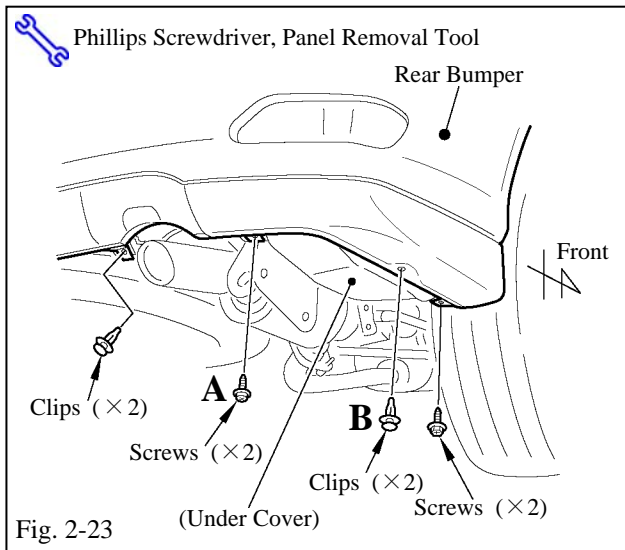

(y) Remove the rear bumper.

NOTE : The illustration shows the right side, but the same applies on the left side.

(1) Remove the screws and clips from the underside (Fig. 2-23).

NOTE : The illustration shows a vehicle with air spring suspension. If the vehicle has coil spring suspension, the under cover, screws A and clips B are absent.

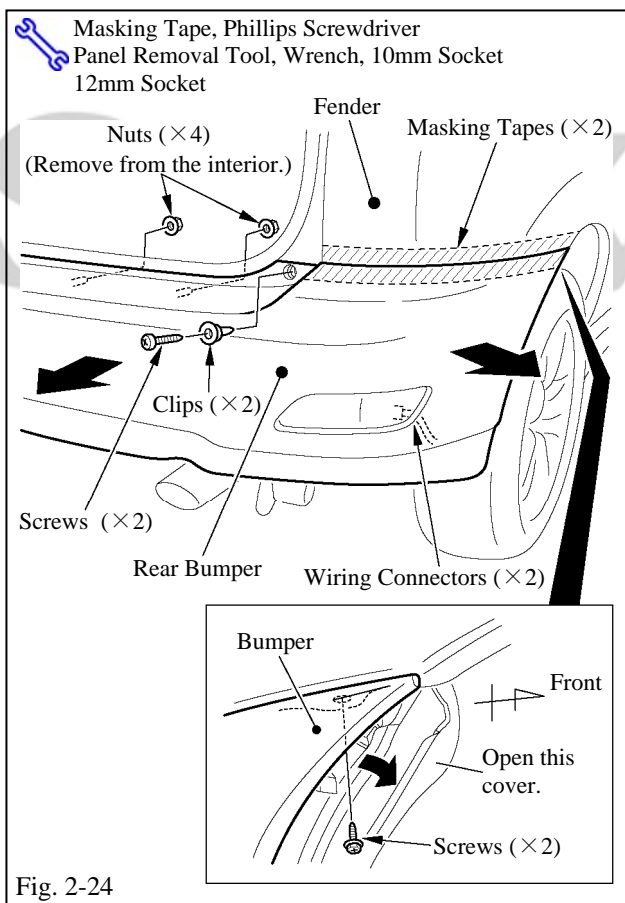

(2) Affix masking tape in the positions shown, to avoid damaging those surfaces (Fig. 2-24).

(3) Remove the upper screws and clips (Fig. 2-24).

(4) Remove the nuts (Fig. 2-24).

(5) Pull the bumper in the direction of the arrows to detach it from the body (Fig. 2-24).

(6) Disconnect the wiring connector (Fig. 2-24).

3. Antenna installation and wiring

- (a) Place the template in the position indicated in the diagram on the rear left edge of the roof, and provisionally fix it with masking tape (Fig. 3-1).

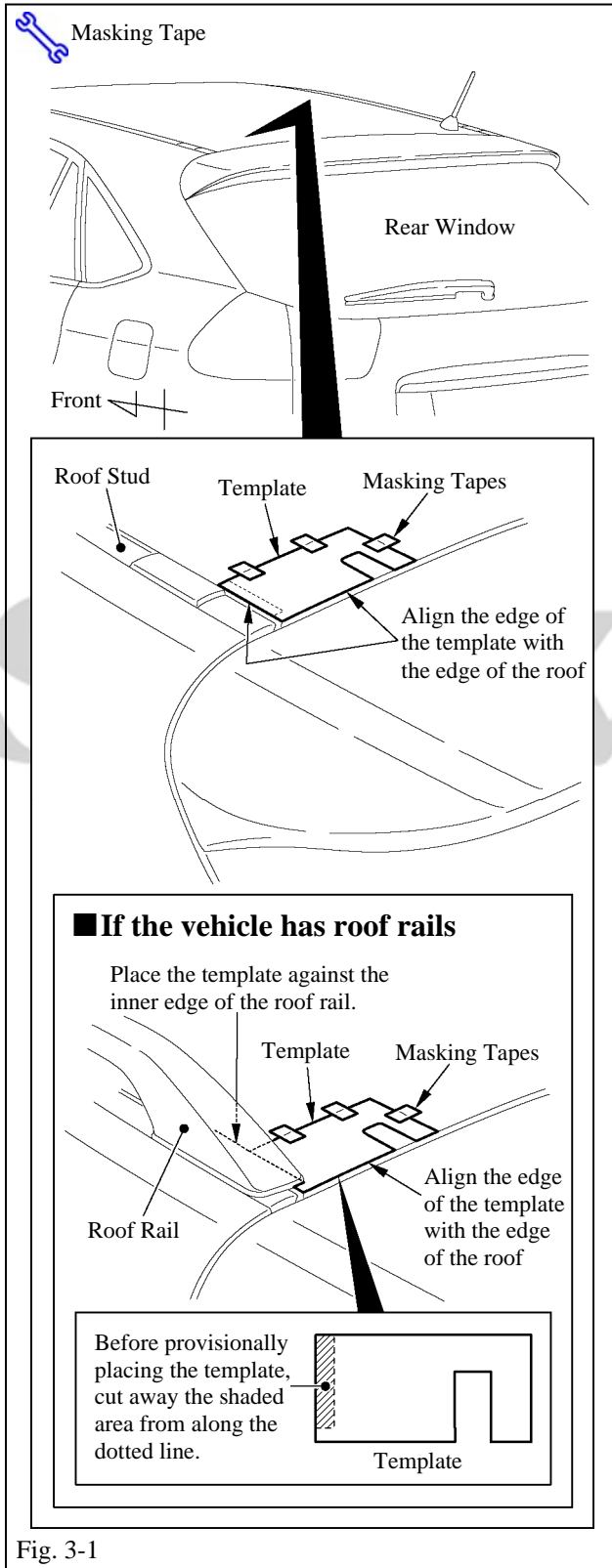
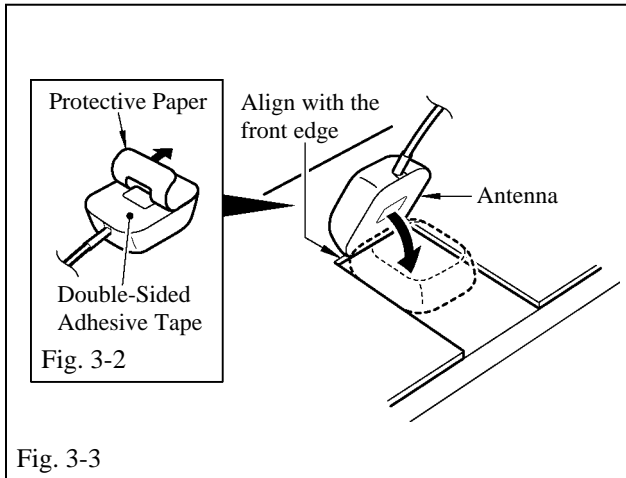

Fig. 3-1



(b) Peel the protective paper off the double-sided adhesive tape on the underside of the antenna (Fig 3-2).

(c) Align the front edge of the antenna with that of the template, then stick it down with a rotating motion (Fig. 3-3).



NOTE : Clean all dirt, oil etc. off the roof before sticking the antenna in place.

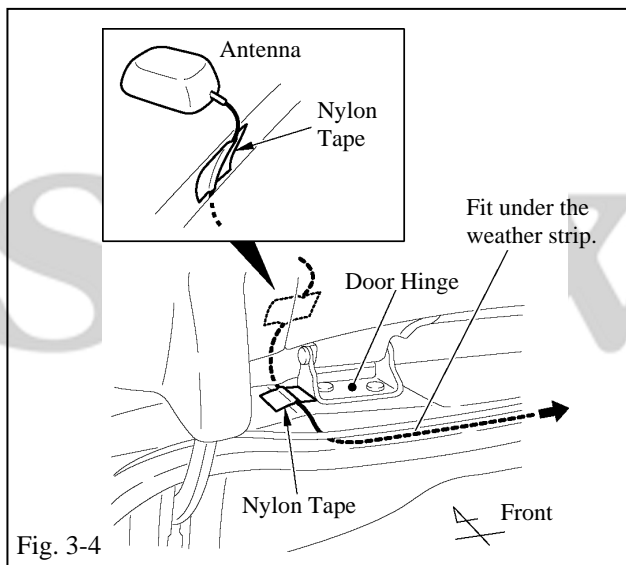

(d) Run the antenna cable through the rear gate.

(1) Fasten with nylon tape along the body face of the rear gate (Fig. 3-4).



NOTE : Clean all dirt, oil etc. off the body face before sticking the nylon tape in place



NOTE : The stickiness of nylon tape is reduced by peeling it off after using it the first time, so do not reuse it.

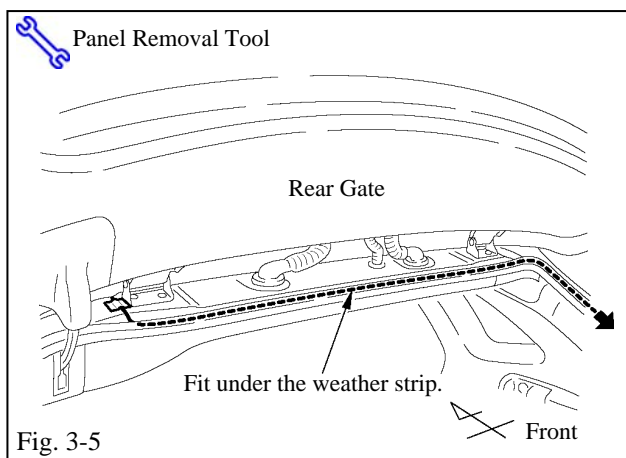

(2) Run the cable along the weather strip as far as the bumper (Fig. 3-5, 3-6).

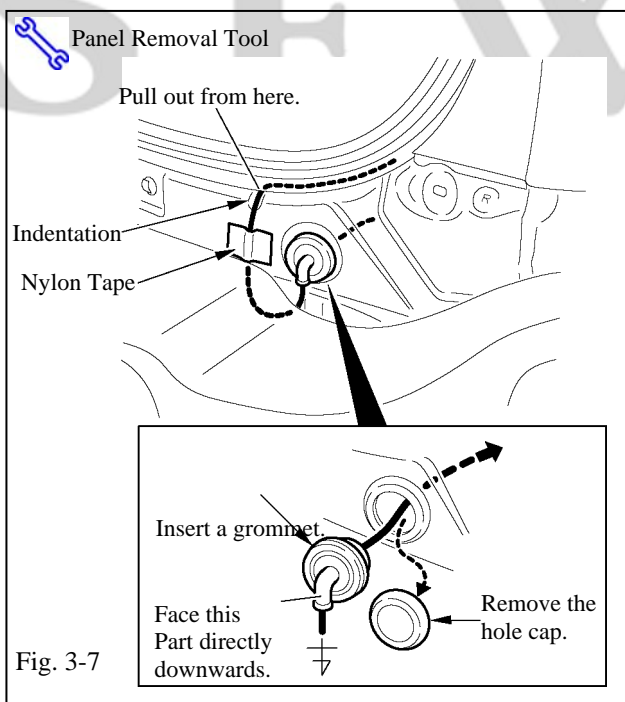
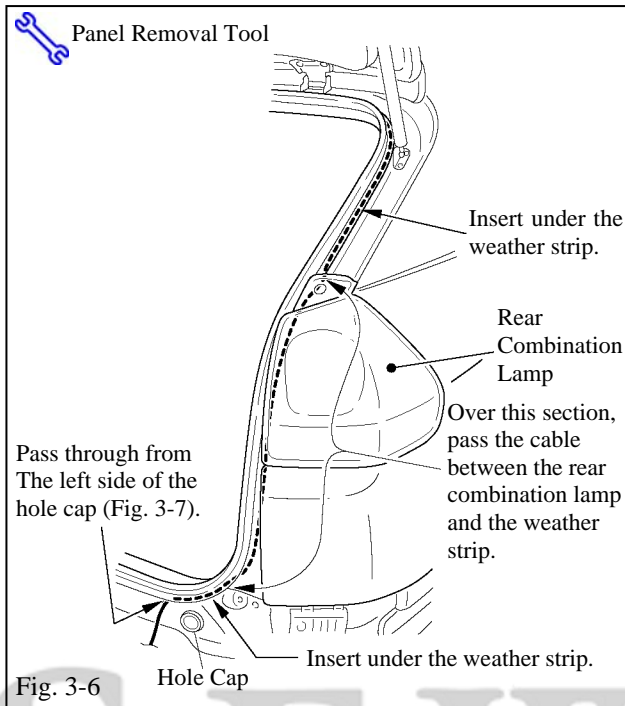

(e) Run the antenna cable into the luggage compartment (Fig. 3-7).

- (1) Remove the hole cap where the cable passes through.
- (2) Run the cable through and fit the grommet.
- (3) Hold the cable down with nylon tape.



NOTE : Clean all dirt, oil etc. off the body face before sticking the nylon tape in place.

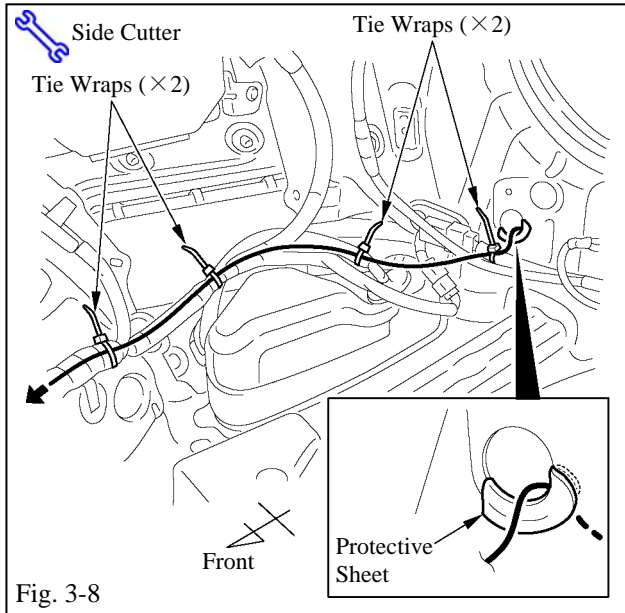

- (4) Affix the protective sheet in the position indicated in the diagram, to protect the cable (Fig. 3-8).
- (5) Use tie wraps to fasten the antenna cable to the harness shown in the diagram (Fig. 3-8).
- (6) Use a side cutter to cut off the excess tie wrap length.

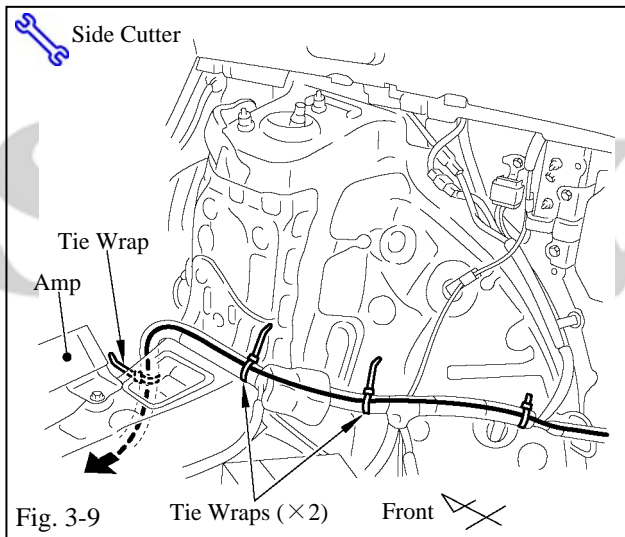

- (f) Run the antenna cable to the tuner mounting position (Fig. 3-9, 3-10).
- (1) Use tie wraps to fasten the antenna cable to the harness shown in the diagram.
- (2) Use a side cutter to cut off the excess tie wrap length.

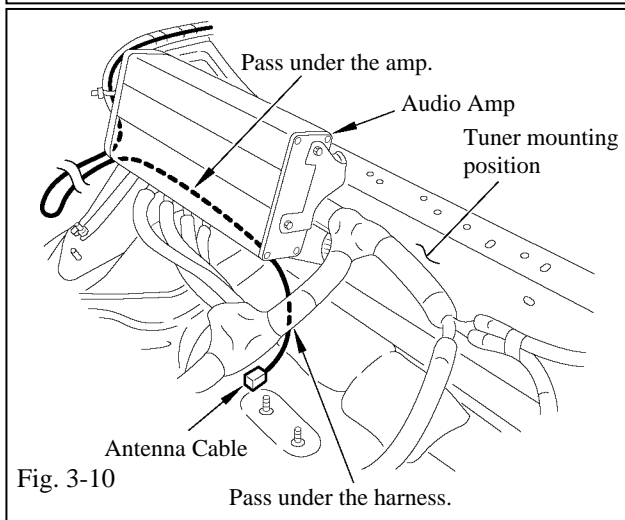

NOTE : Excess cable length can be stored with the tuner cable, next to the audio amp. Refer to step 5. (d) in the procedure for the method.

4. Tuner cable wiring

(a) Wiring to the audio unit

- (1) Bring the tuner cable in from the indicated position in the glove box and run it to the audio unit mounting position (Fig. 4-1).

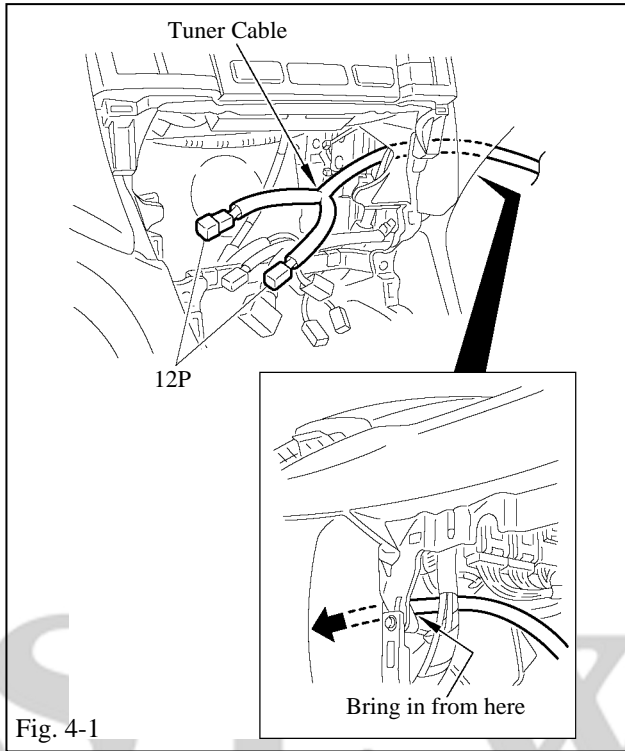

- (2) Connect the tuner cable to the audio harness (Fig. 4-2).

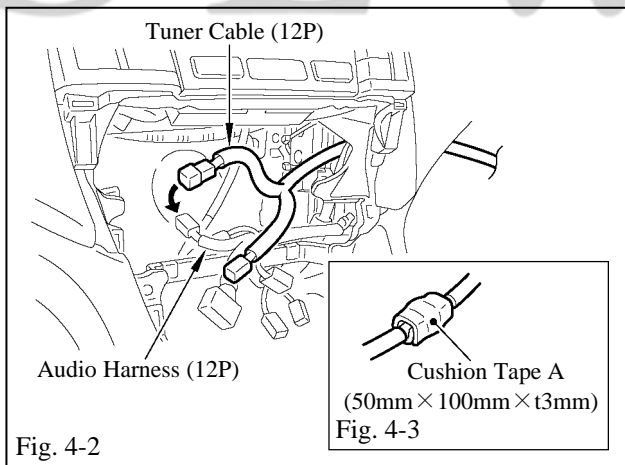

- (3) Wrap cushion tape A around the connector connection position (Fig. 4-3).

- (4) Connect the tuner cable to the audio unit (Fig. 4-4).

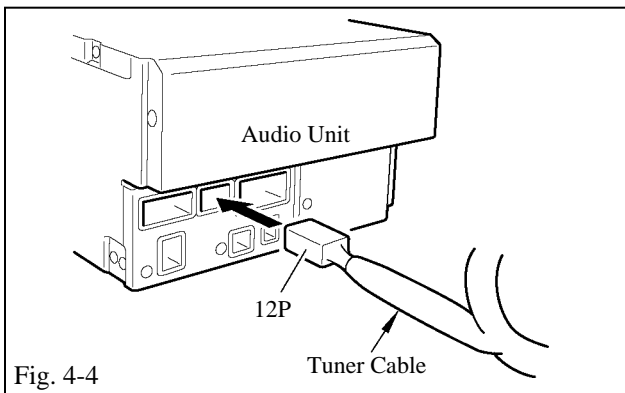

- (5) Replace the audio unit.

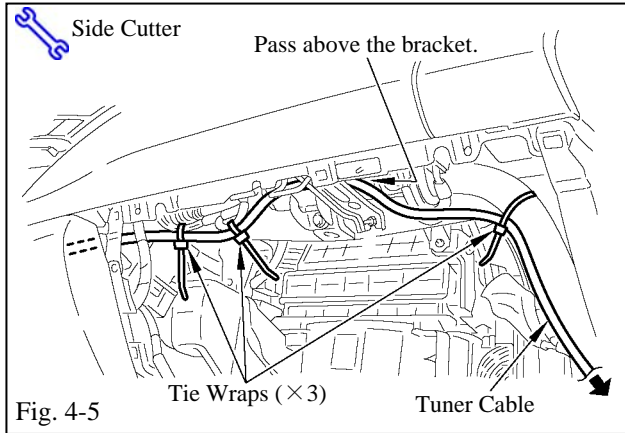

(b) Wiring through the glove box

- (1) Fasten the cable to the indicated bracket and harness with tie wraps (Fig. 4-5).
- (2) Use a side cutter to cut off the excess tie wrap length.

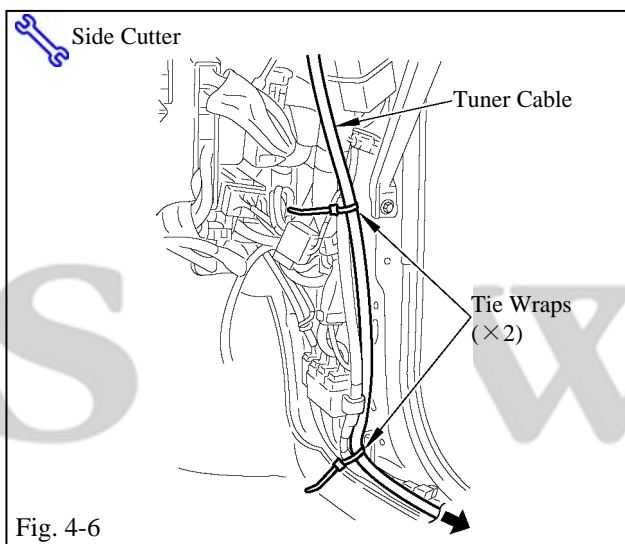

(c) Wiring through the cowl side

- (1) Fasten the cable to the indicated harness with tie wraps (Fig. 4-6).
- (2) Use a side cutter to cut off the excess tie wrap length.

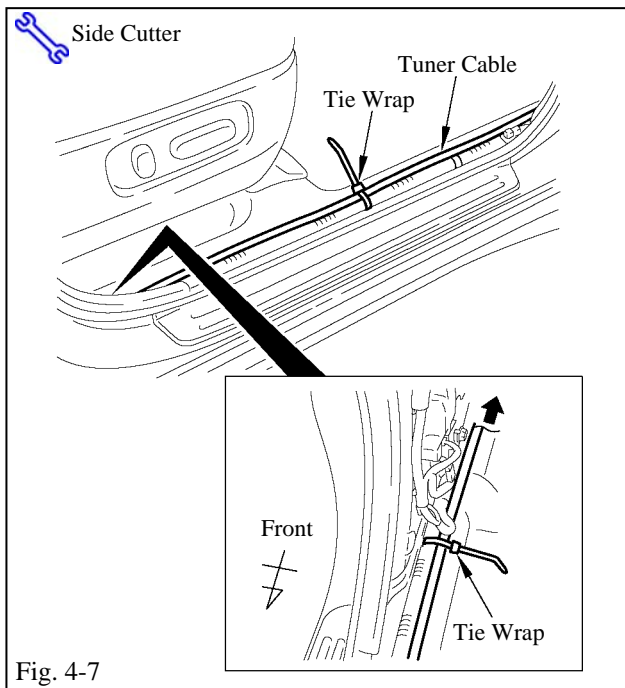

(d) Wiring behind the front scuff plate

- (1) Fasten the cable along the indicated harness with tie wraps (Fig. 4-7).
- (2) Use a side cutter to cut off the excess tie wrap length.

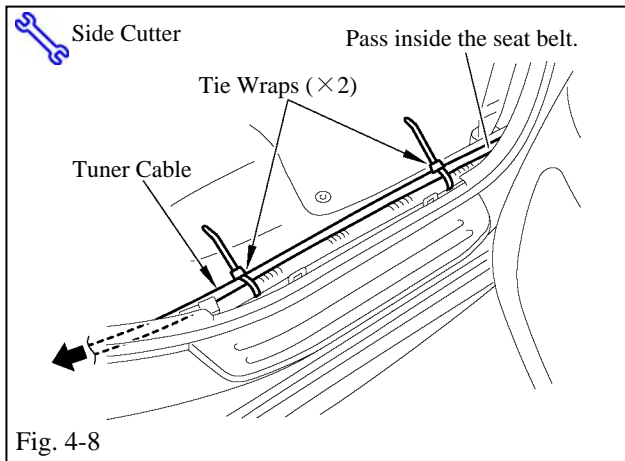

(e) Wiring behind the rear scuff plate

- (1) Fasten the cable along the indicated harness with tie wraps (Fig. 4-8).
- (2) Use a side cutter to cut off the excess tie wrap length.

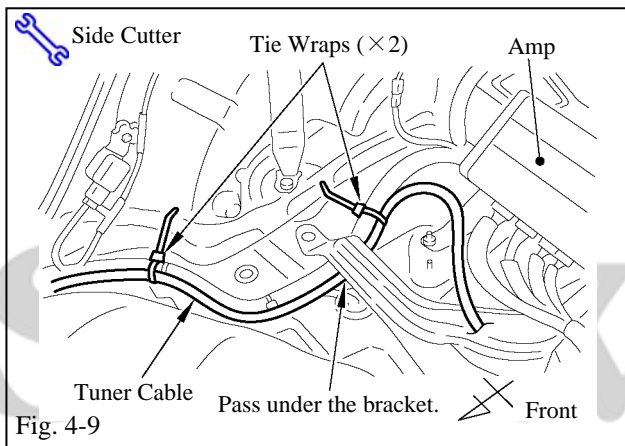

(f) Wiring around the rear seat

- (1) Fasten the cable along the indicated harness with tie wraps (Fig. 4-9).
- (2) Use a side cutter to cut off the excess tie wrap length.

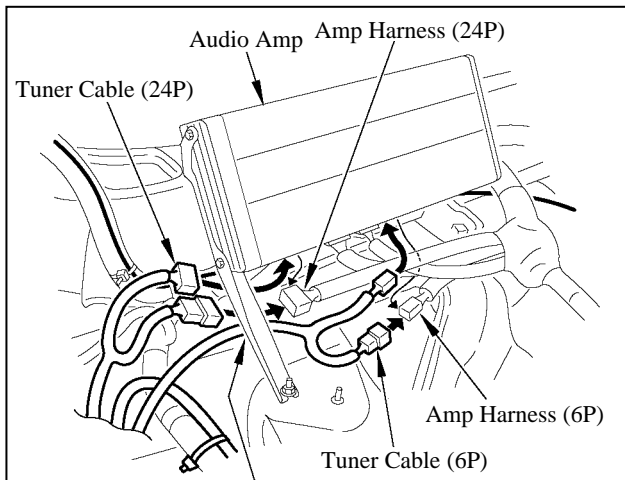

(g) Connection to the audio amp

- (1) Disconnect the wiring connector from the amp and interpose the tuner cable before reconnecting (Fig.4-10).

NOTE : The illustration shows a vehicle equipped with Mark Levinson Audio, but the procedure is the same for standard audio amp.

- (2) Wrap cushion tape A around the connector connection positions (Fig. 4-11).

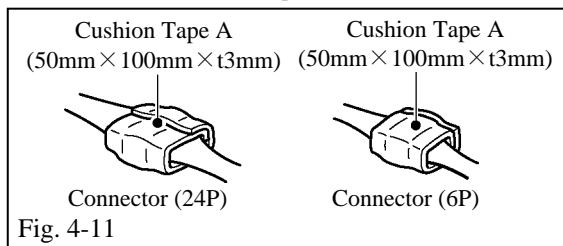

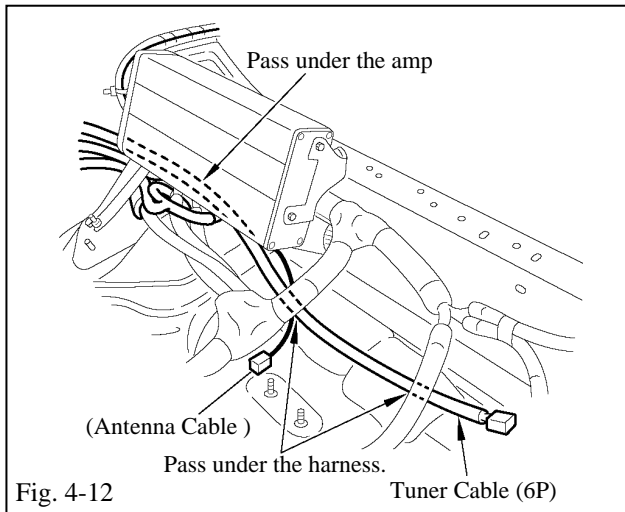

(h) Run the cable to the tuner mounting position (Fig. 4-12).

NOTE : Excess cable length can be stored with the antenna cable, next to the audio amp. Refer step 5. (d) in procedure for the method.

5. Tuner installation and Wiring

(a) Attach tuner brackets A and B the tuner (Fig. 5-1).

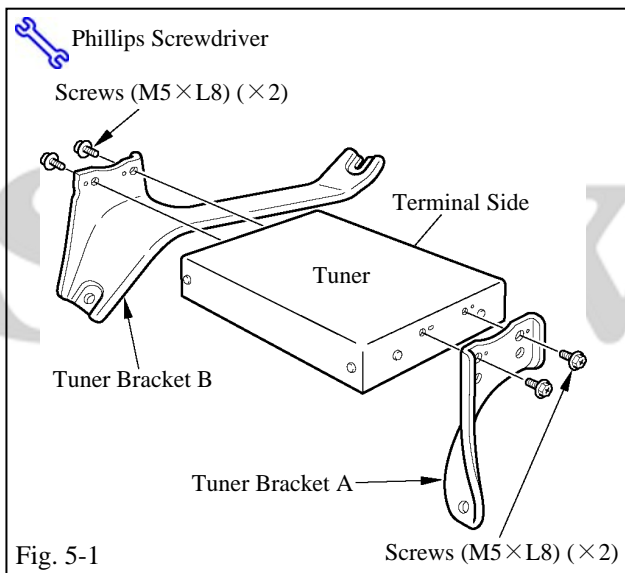

(b) Mount the tuner to the floor.

NOTE : The illustration shows a vehicle equipped with Mark Levinson Audio, but the procedure is the same for standard audio amp.

(1) Affix cushion tape B to the indicated position on the floor (Fig. 5-2).

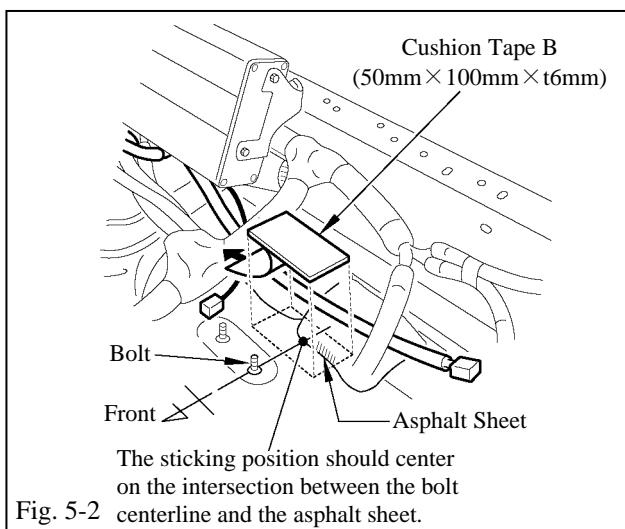

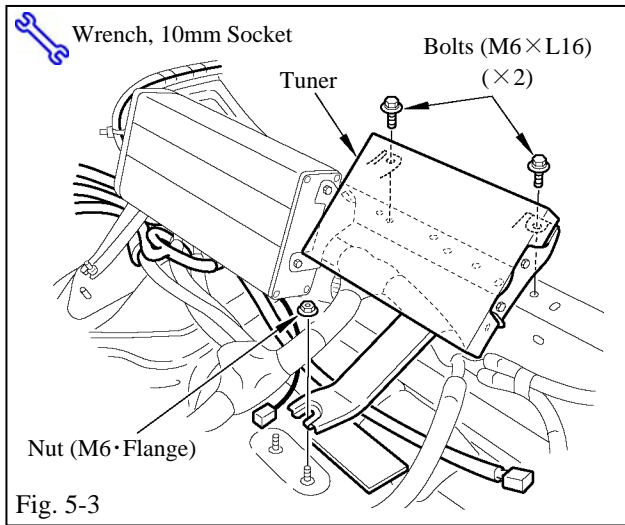

(2) Use the nut and bolts to fasten the tuner to the floor (Fig. 5-3).

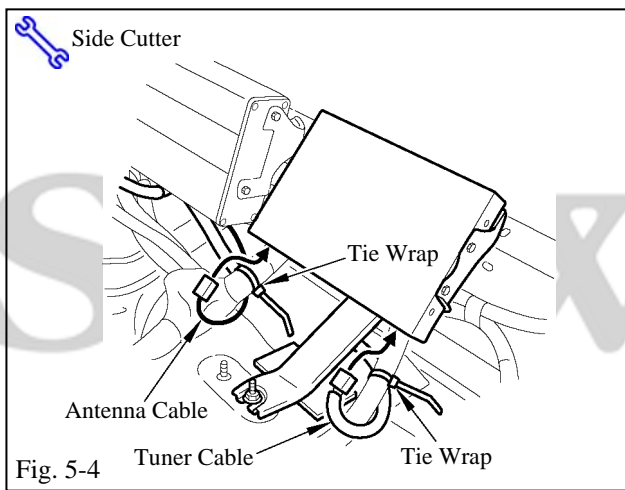

(c) Connect the antenna cable and tuner cable to the tuner (Fig. 5-4).

- (1) Use tie wraps to fasten the antenna and tuner cables to the indicated harness.
- (2) Use a side cutter to cut off the excess tie wrap length.

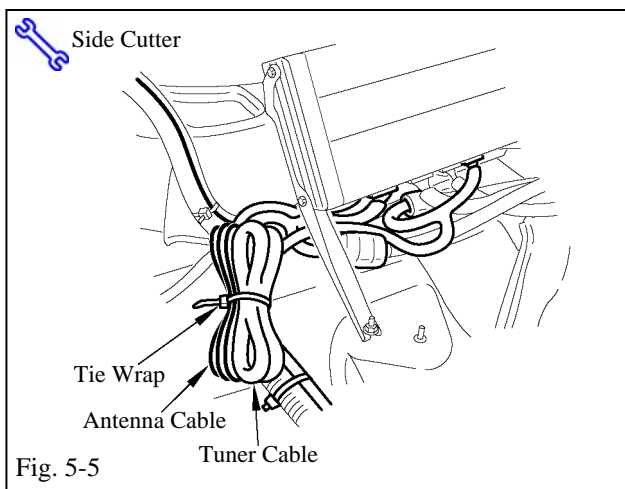

(d) Dealing with excess cable length

- (1) Bundle the excess lengths of the tuner cable and antenna cable together and fasten them to the indicated harness with tie wraps (Fig. 5-5).



NOTE : Tie the cables so that they do not get in the way when putting back the floor bracket and the luggage side trim.

- (2) Use a side cutter to cut off the excess tie wrap length.

6. Completing the installation

- (a) Complete the reassembly of the vehicle.
 - (1) Reconnect any disconnected connectors.
 - (2) Verify the panels fit together properly with no uneven gaps between them.
 - (3) When putting the rear seat mounting bolts back, tighten them to 37 N-m (27 lbs-ft).
- (b) Clean up and remove any trash.
- (c) Reconnect the vehicle's negative battery cable (Fig. 6-1).
 - (1) Position the negative terminal at original factory position.
 - (2) Tighten the nut to 4.1N•m (36 lbf•in).
 - (3) Do not touch the positive terminal with any tool when replacing the cable.
- (d) After the battery cable is reconnected, the functional components of the car need to be re-initialized. Initialize them with reference to RM0270U in the vehicle repair manual.

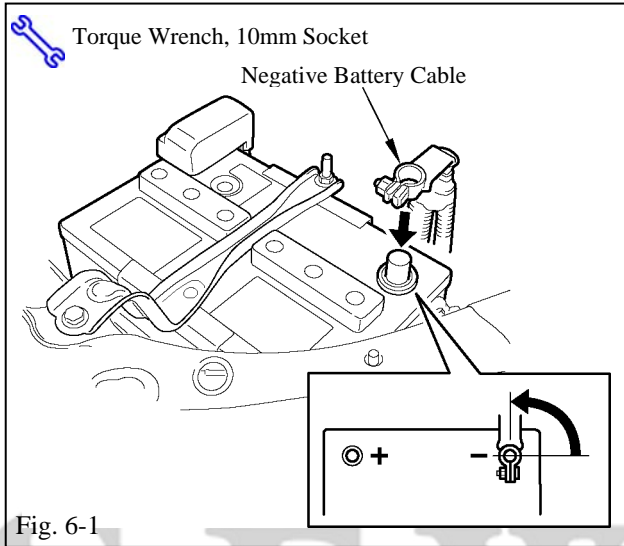

Fig. 6-1

LEXUS RX350 2007 - XM SATELLITE RADIO TUNER
 Checklist - these points **MUST** be checked to ensure a quality installation.

Check:

Look For:

Accessory Function Checks

- Verify the proper operation of the satellite radio tuner referring to the receiver assy and radio owner's manuals.
- Verify the proper operation of the receiver assy and radio referring to the receiver assy and radio owner's manuals.

Vehicle Function Checks

- Cigarette Lighter
- Height Control Switch (if equipped)
- Seat Heater Switch (if equipped)
- Head Lamp Wiper Switch (if equipped)
- Front Door Scuff Light (if equipped)
- Tire pressure switch (if equipped)
- Rear Door Scuff Light (if equipped)
- Rear Gate Opener Switch
- Rear Fog Lamp
- Navigation System (if equipped)
- After the battery cable is reconnected, the functional components of the car need to be re-initialized. Initialize them with reference to RM0270U in the vehicle repair manual.

- Functioning Cigarette Lighter
- Functioning Height Control Switch
- Functioning Seat Heater Switch
- Functioning Head Lamp Wiper Switch
- Functioning Front Door Scuff Light
- Functioning Tire pressure switch
- Functioning Rear Door Scuff Light
- Functioning Rear Gate Opener Switch
- Functioning Rear Fog Lamp
- Functioning Navigation System