



**Technical Service
Information Bulletin**

July 29, 2002

Title:

CHILD RESTRAINT SEAT TOP STRAP BRACKET INSTALLATION

Models:

'90 – '00 All Models

BODY
B0004-02

Introduction Child restraint seat top strap bracket installation procedures are provided to supplement the Owner's Manual. Beginning with 2001 models, the top strap brackets are factory installed.

NOTE:

- The child restraint seat top strap assembly is not available as a service part. Contact the child restraint seat manufacturer for recommended top strap information, top strap to child restraint seat installation instructions, and top strap retailers.
- The top strap brackets can only be installed on vehicles that have nuts welded in place by the factory. The locations of these nuts can be found in the Owner's Manual (for most 1990 and newer models). Lexus does not recommend modifying vehicles that do not have nuts welded in place by the factory. All LX 450 and LX 470 vehicles, prior to 2001 model year, may not have these nuts welded in by the factory.

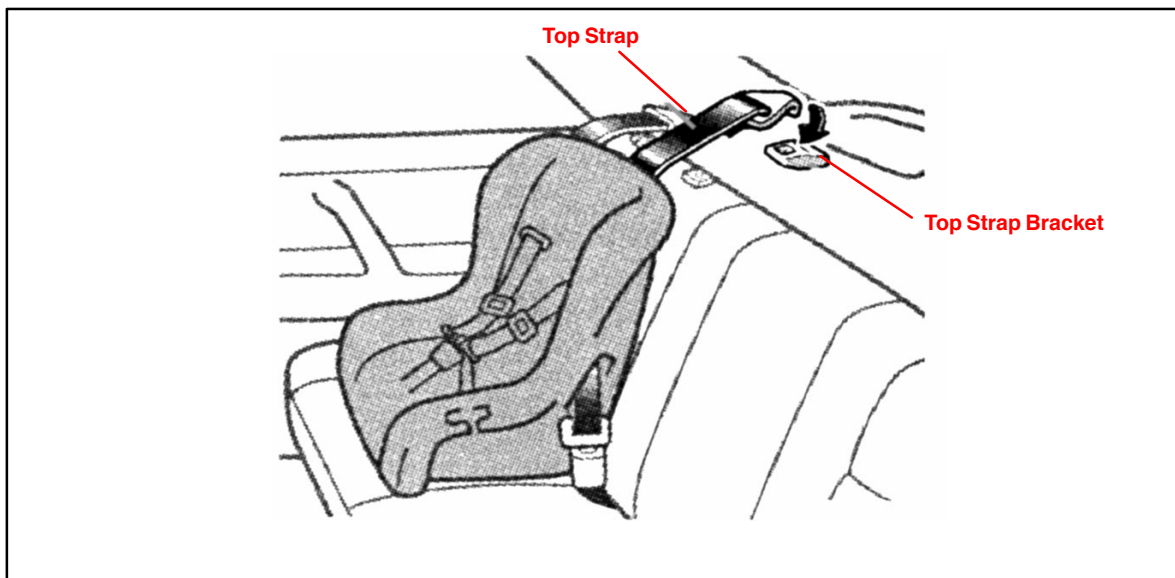

**Applicable
Vehicles**

- 1990 – 2000 model year vehicles, all models.

**Parts
Information**

PART NUMBER	PART NAME
73709-12010	Bracket Sub-Assembly (Bracket, Bolt, 10 mm Spacer, and Washers)
04731-22012	CRS Kit (two Bolts [15 mm, 30 mm], three Spacers [5 mm, 10 mm, 15 mm], and Locking Clip)

**Warranty
Information**

OP CODE	DESCRIPTION	TIME	OFF	T1	T2
N/A	Not Applicable to Warranty	-	-	-	-



**Installation
Procedure****Child Restraint Seat Top Strap Bracket Installation**

Obtain the exact year and vehicle model Lexus Owner's Manual before beginning installation.

1. Confirm with the customer which seat location(s) they will be installing the child restraint seat. The Owner's Manual seat section provides an illustration showing available top strap bracket location(s). The illustration page in the Owner's Manual is provided on page 4 of this bulletin.

NOTE:

Determine which kit parts are needed for each specific child seat location, by referring to page 4 of this bulletin.

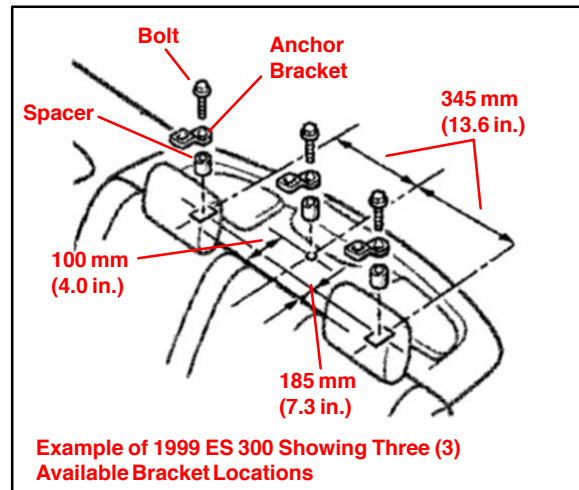

2. Remove a 20 mm diameter area of the carpet or trim material above the bracket mounting location. In some vehicles, a 20 mm circle is already pre-cut into the interior trim material. Once the interior trim material is removed, the nuts welded in by the factory should be visible.

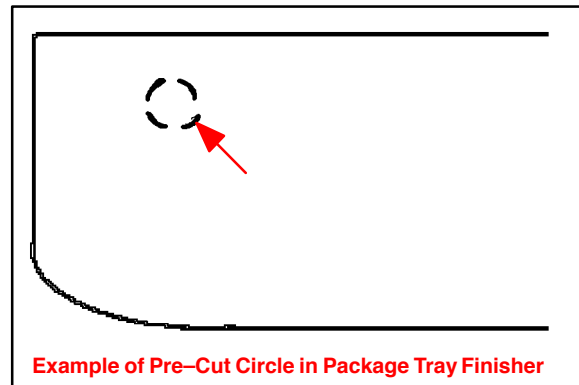

3. If a 5 mm or 15 mm spacer is specified, remove the red lock washer from the Bracket Sub-Assembly (P/N 73709-12010) and remove the 10 mm spacer. Assure the red lock washer is re-installed onto the bolt. If a 5 mm spacer is needed, use the 15 mm bolt from the CRS Kit (P/N 04731-22012).

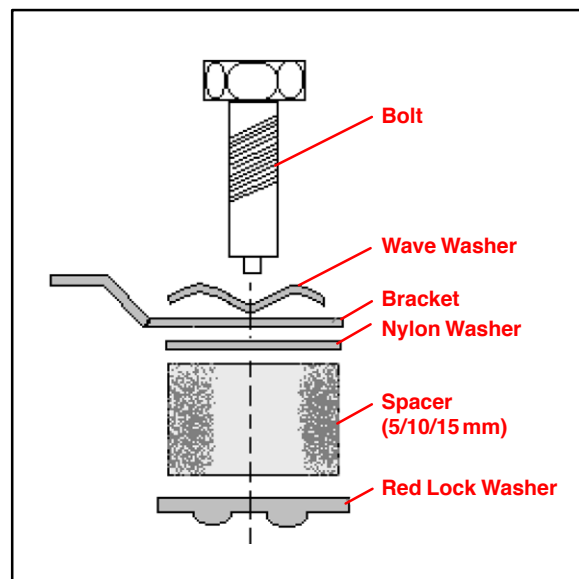

Installation Procedure
(Continued)

4. Install the bracket assembly, according to the directions in the Owner's Manual. Tighten the bolt to 16.5 – 24.7 N–m, (1.68 – 2.52 kgf–m, 12.2 – 18.2 ft–lbf).
 - Assure the top strap is attached to the child seat, according to the child seat manufacturer's instructions.
 - Assure the child seat is installed in the vehicle according to the Lexus Owner's Manual (seat section).

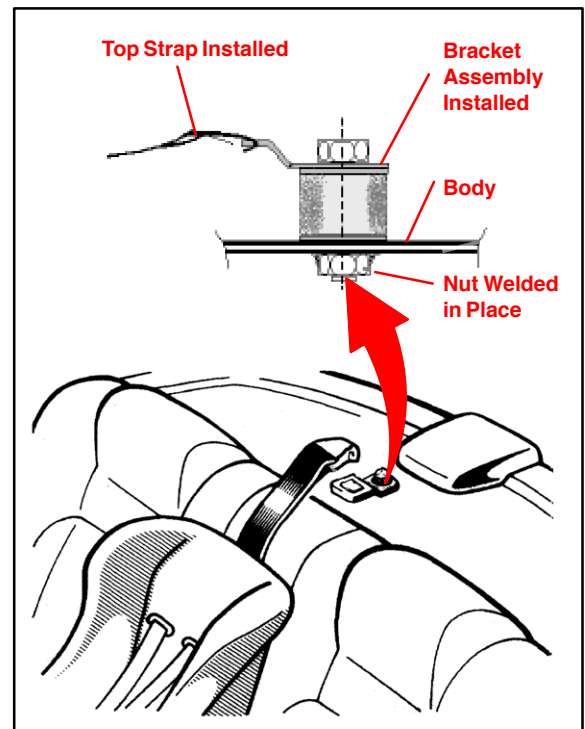

Installation Reference Information

Owner's Manual Installation Reference Information

Page 4 of this bulletin is a reference chart containing:

- Owner's Manual page(s) that provide the illustration showing available top strap bracket location(s). The information goes back to 1990 model year. 2001 models and newer already had the bracket installed by the factory.
- Installation notes, such as bracket spacer sizes for each specific child seat location.

EXAMPLE:

OWNER'S MANUAL	ES 300
1997	pg 89–90 a

This cell contains information on the 1997 ES300

Refer to this page in the Owner's Manual to find the illustration showing available top strap bracket locations.

Installation Note. In this case, all bracket positions on the 1997 ES 300 will require a 15 mm spacer.

INSTALLATION NOTE	COMMENT
a	Spacer – 15 mm for all anchors
b	Spacer – 10 mm for outer, 15 mm for center
c	Spacer – 15 mm for outer, 10 mm for center
d	Spacer – 5 mm for all anchors
N/A	Top strap anchor bracket mounting not available
Standard	No installation necessary, anchor already installed by factory

**Installation
Reference
Information**
(Continued)

OWNER'S MANUAL	LS 400	ES 300	ES 250	SC 400	SC 300
2000	pg 117–118 Standard	pg 114–115 Standard		N/A	N/A
1999	pg 112–114 a	pg 105–106 a		N/A	N/A
1998	pg 111–113 a	pg 99–100 a		N/A	N/A
1997	pg 98–100 a	pg 89–90 a		pg 91–92 a	pg 91–92 a
1996	pg 79–82 a	pg 67–68 c		pg 72–73 a	pg 72–73 a
1995	pg 77–80 a	pg 67–68 c		pg 70–71 a	pg 70–71 a
1994	pg 74–75 b	pg 68–69 c		pg 67–68 a	pg 67–68 a
1993	pg 74–75 b	pg 60–61 c		pg 67–68 a	pg 67–68 a
1992	pg 62 b	pg 61–62 c		pg 61–62 a	pg 61–62 a
1991	pg 61–62 b		pg 59–60 a		
1990	pg 61 b		pg 55–56 a		

OWNER'S MANUAL	GS 400	GS 300	LX 470	LX 450	RX 300
2000	pg 112–113 Standard	pg 112–113 Standard	N/A		pg 126–127 d
1999	pg 108–109 a	pg 108–109 a	N/A		pg 123–124 d*
1998	pg 107–108 a	pg 107–108 a	N/A		
1997		pg 97–98 a		N/A	
1996		pg 70–72 a		N/A	
1995		pg 69–70 a			
1994		pg 69–70 a			
1993		pg 69–70 a			
1992					
1991					
1990					

* 1999 RX 300 Owner's Manual OM48403U refer to pages 126–127.