

1 RX 300 ELECTRICAL WIRING DIAGRAM

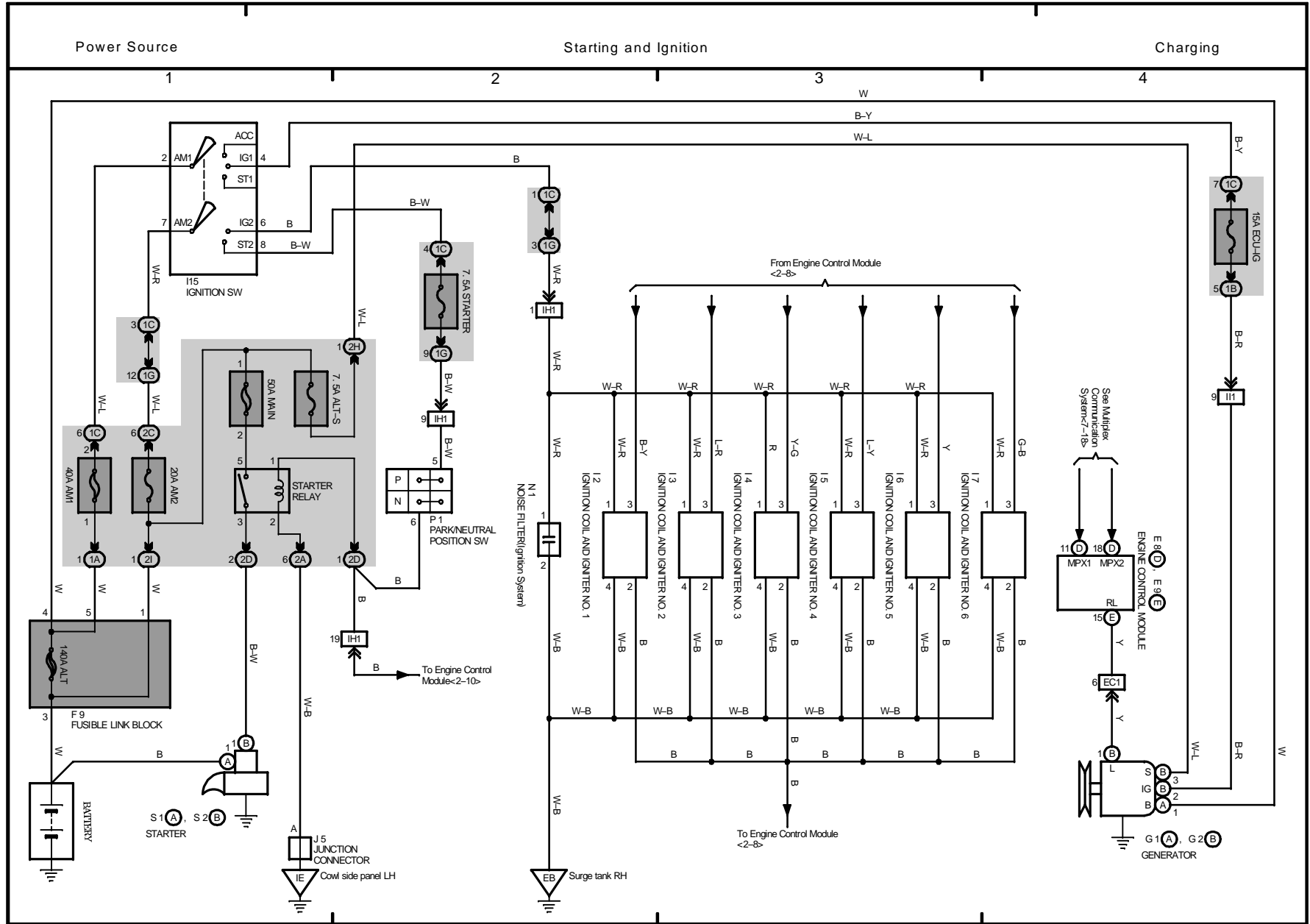

2000 LEXUS RX 300 (EWD395U)

Engine Control and Engine Immobiliser System

* 1 : Shielded

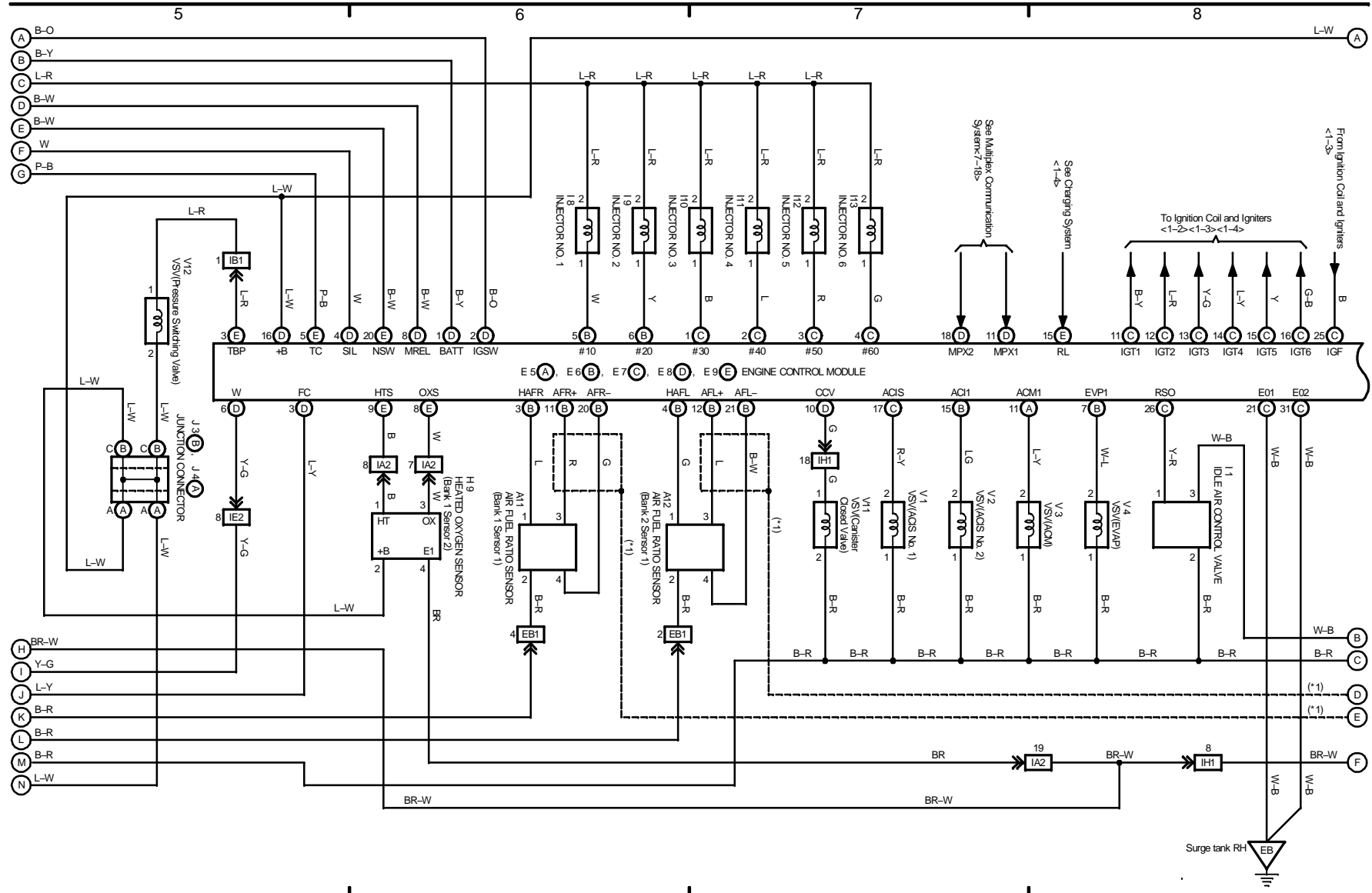

2000 LEXUS RX 300 (EWD395U)

OVERALL ELECTRICAL WIRING DIAGRAM

Engine Control and Engine Immobiliser System

* 1 : Shielded

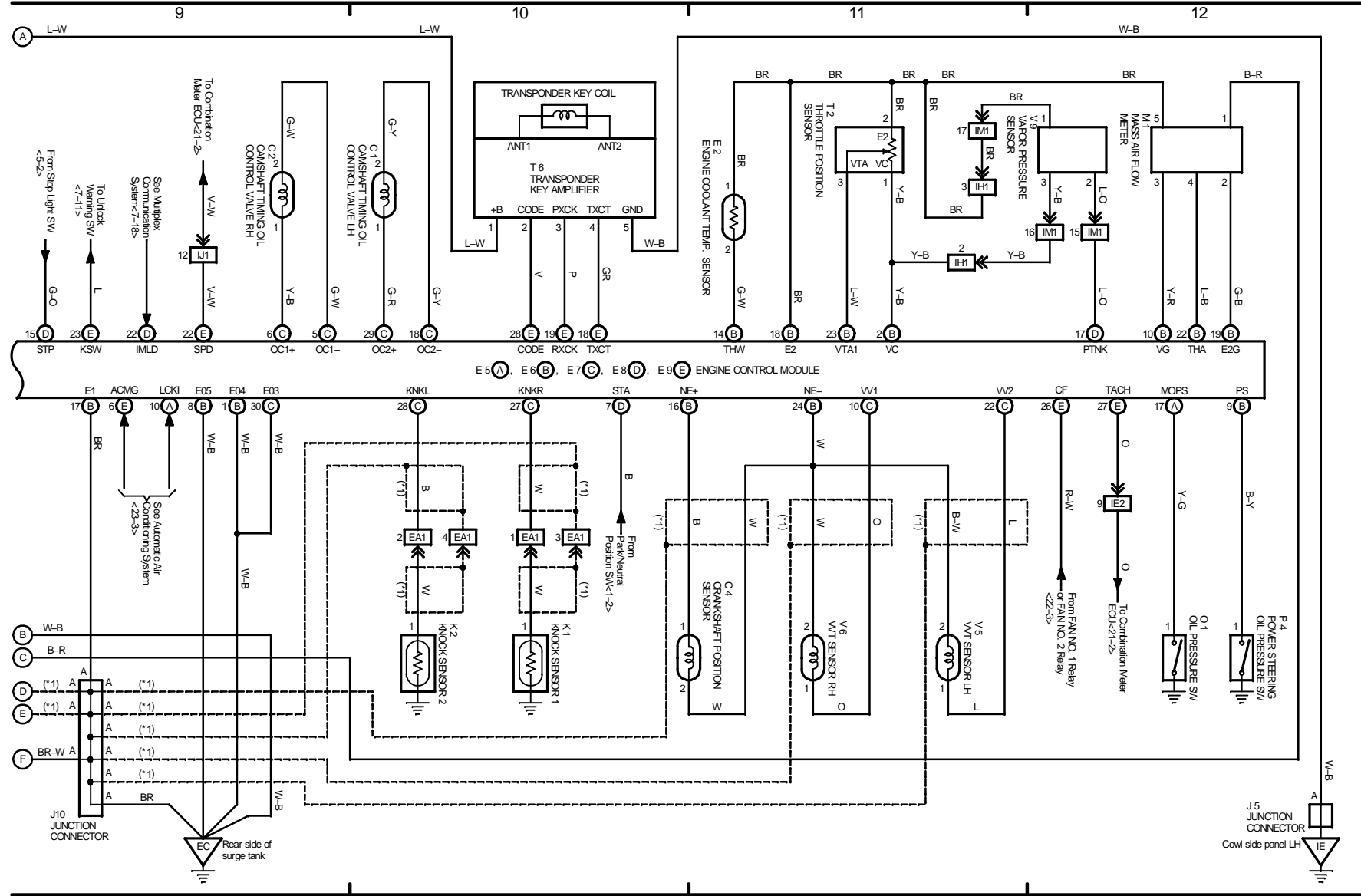

2000 LEXUS RX 300 (EWD395U)

2 RX 300 (Cont' d)

M OVERALL ELECTRICAL WIRING DIAGRAM

3 RX 300

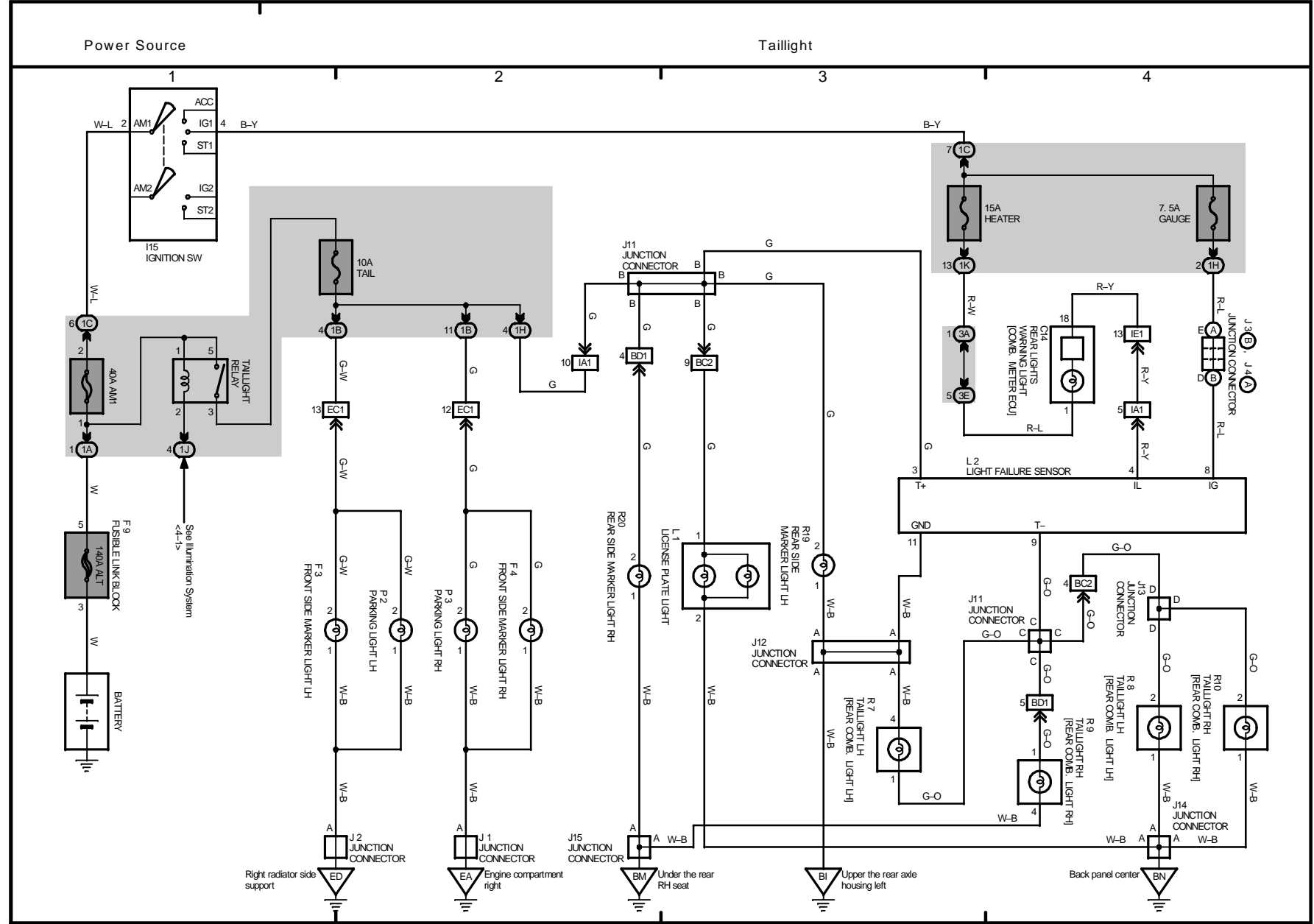

2000 LEXUS RX 300 (EWD395U)

M OVERALL ELECTRICAL WIRING DIAGRAM

5 RX 300

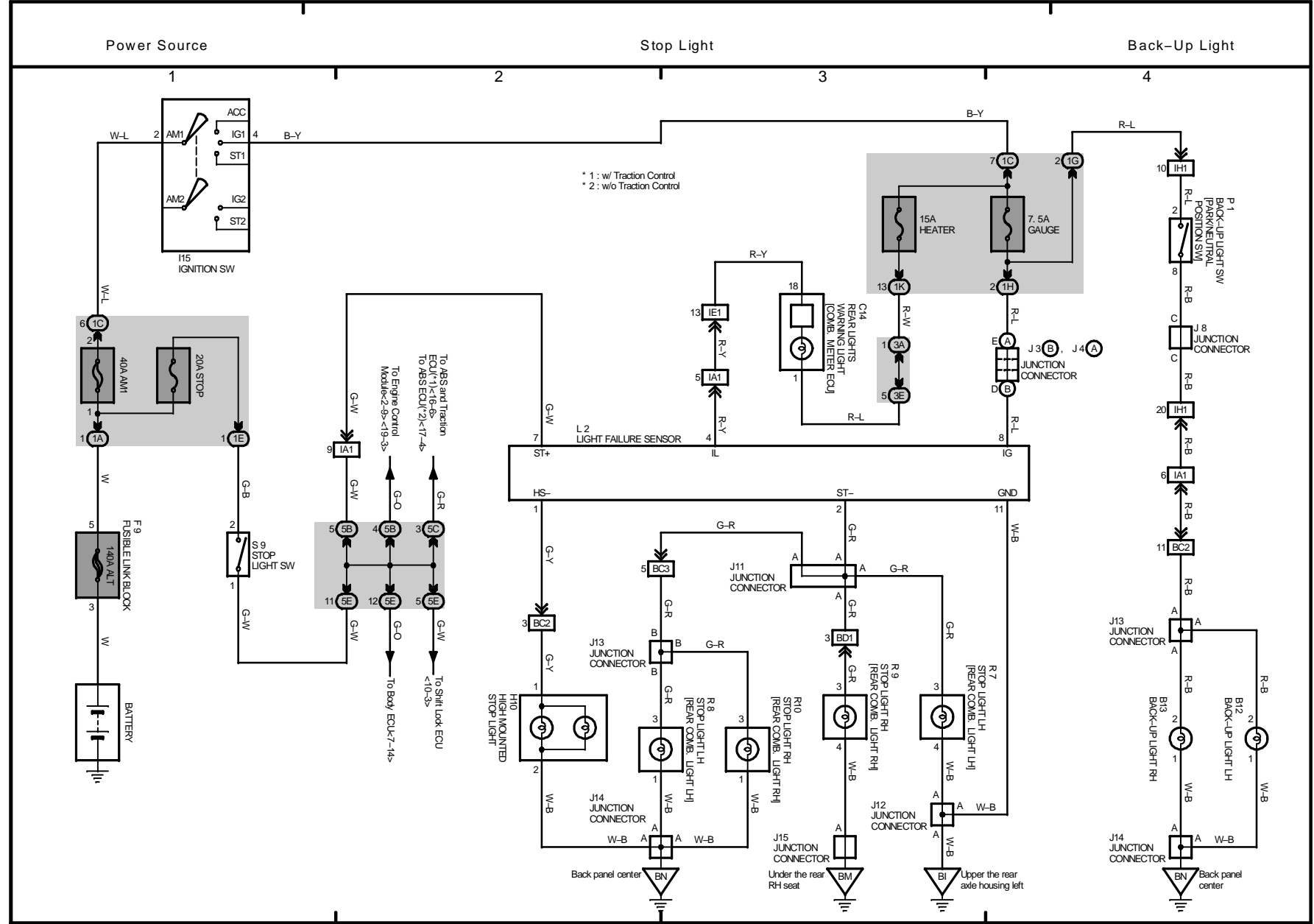

M OVERALL ELECTRICAL WIRING DIAGRAM

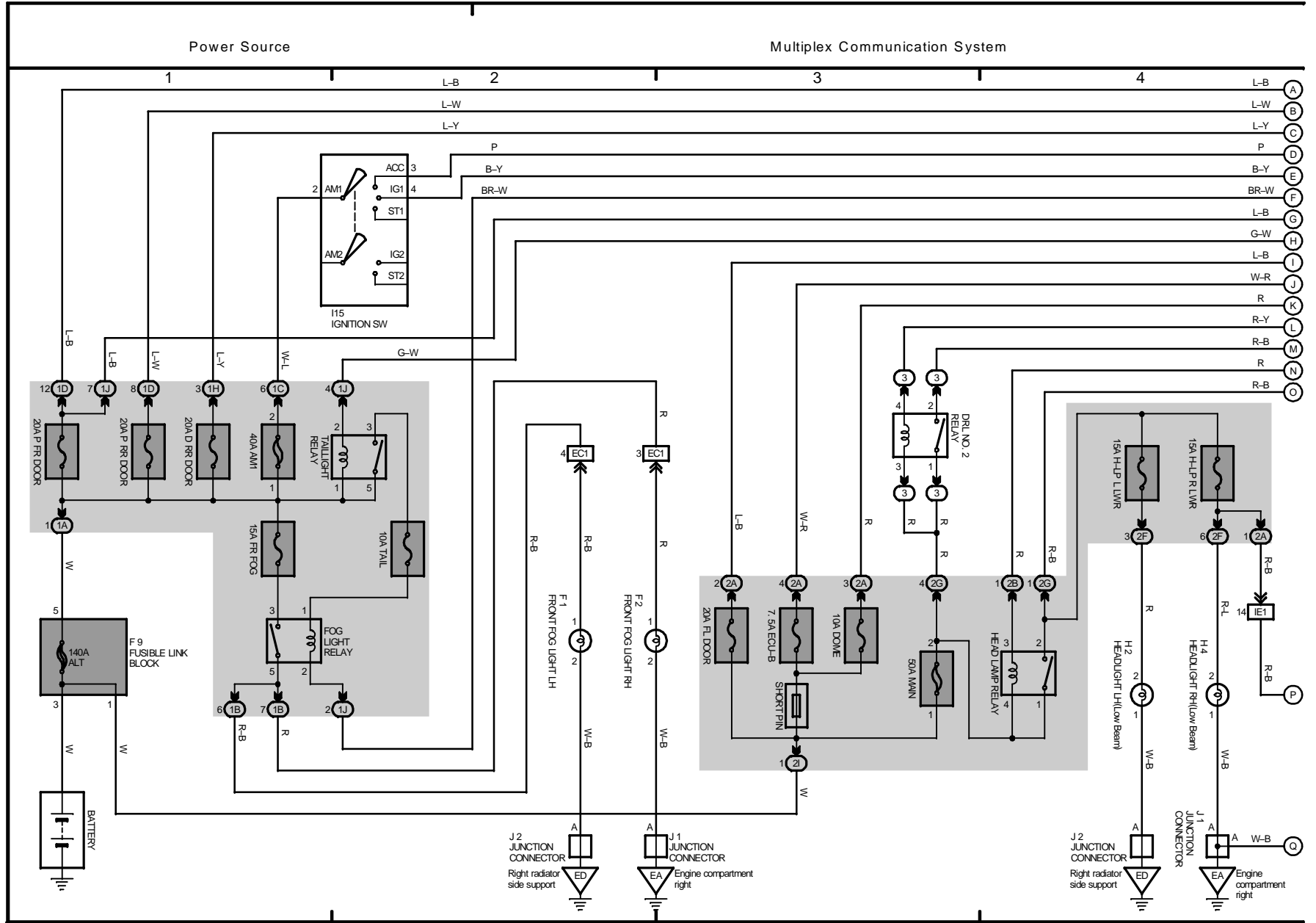

2000 LEXUS RX 300 (EWD395U)

Multiplex Communication System

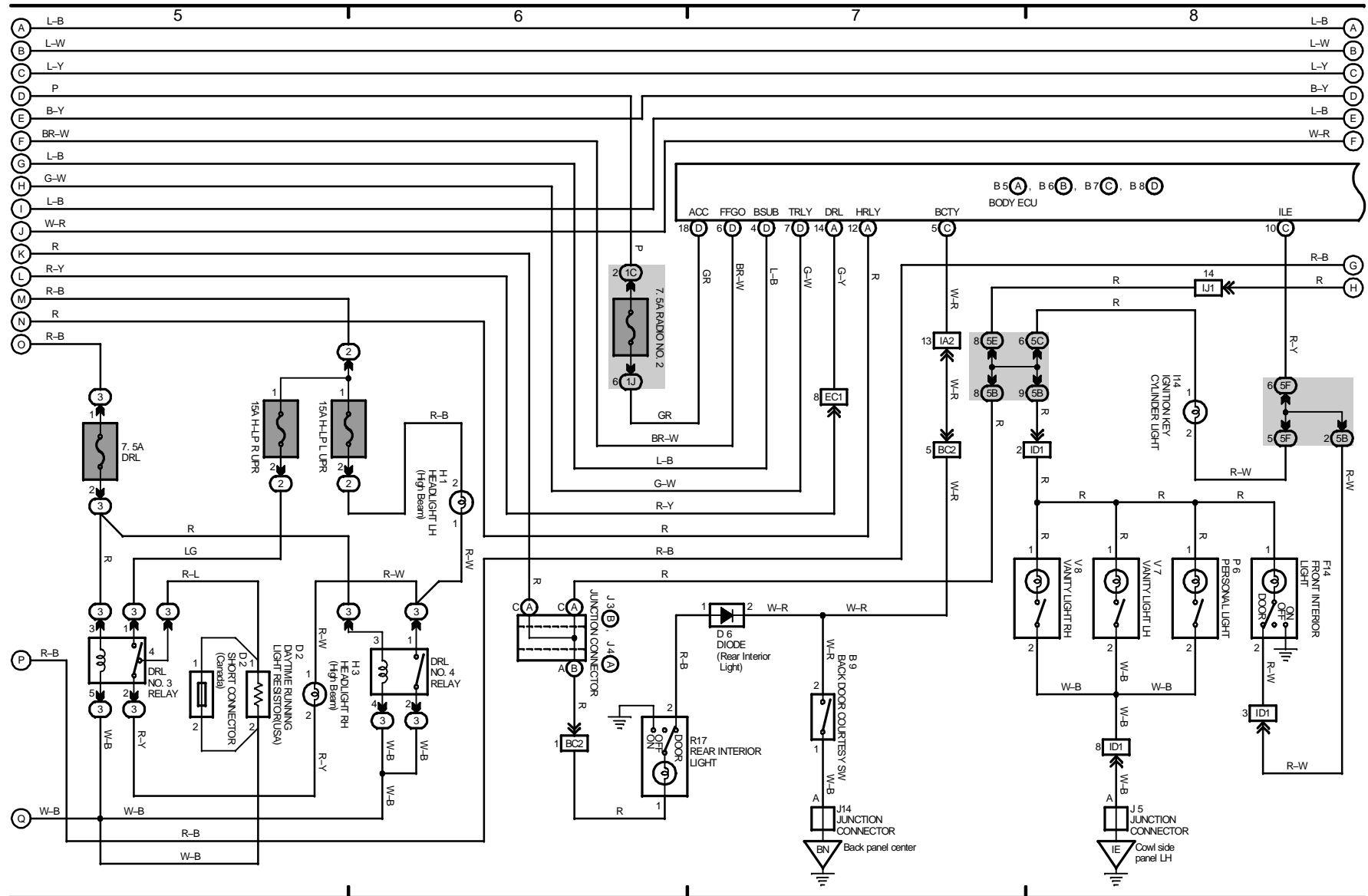

2000 LEXUS RX 300 (EWPD395U)

M OVERALL ELECTRICAL WIRING DIAGRAM

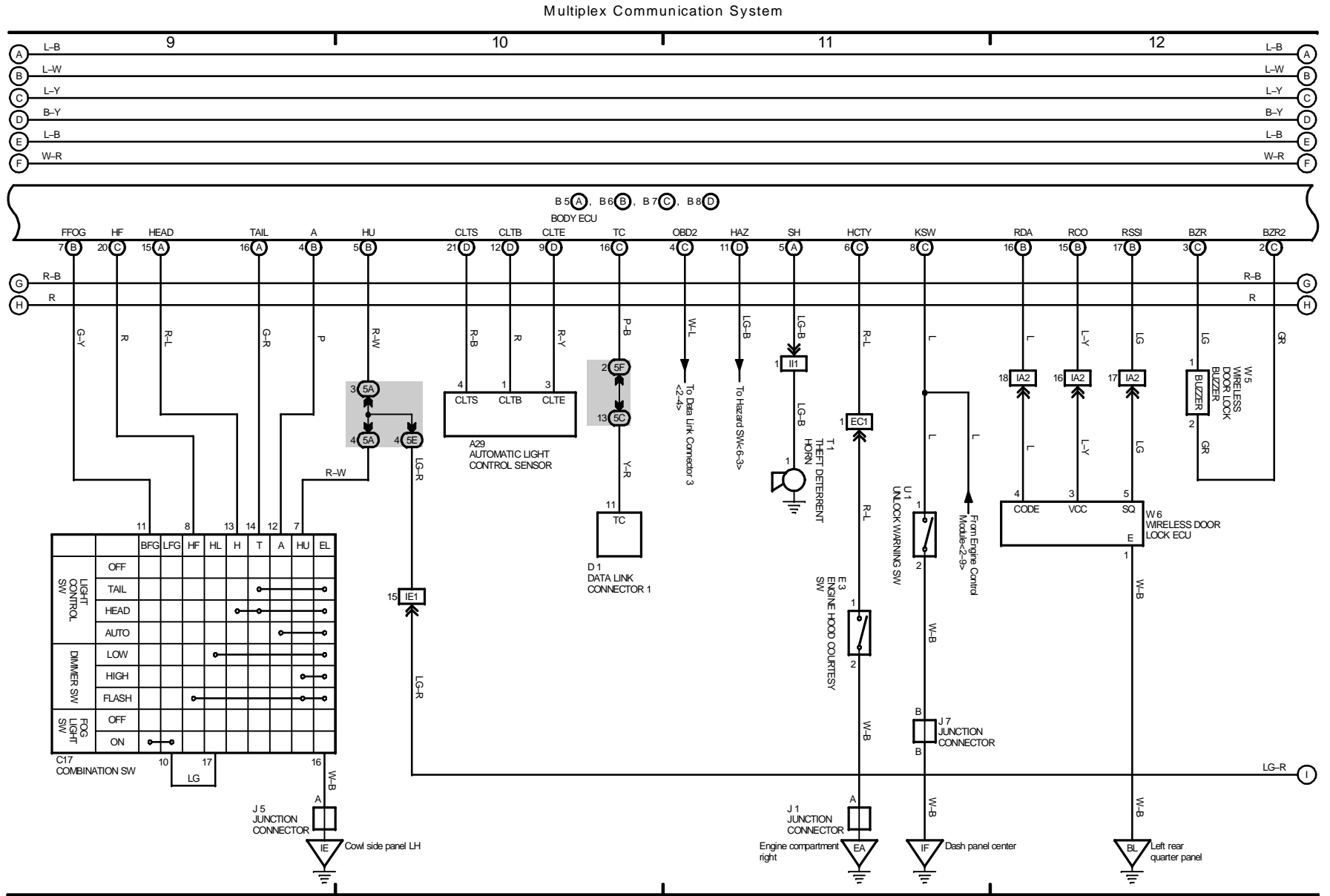

2000 LEXUS RX 300 (EWD395U)

Multiplex Communication System

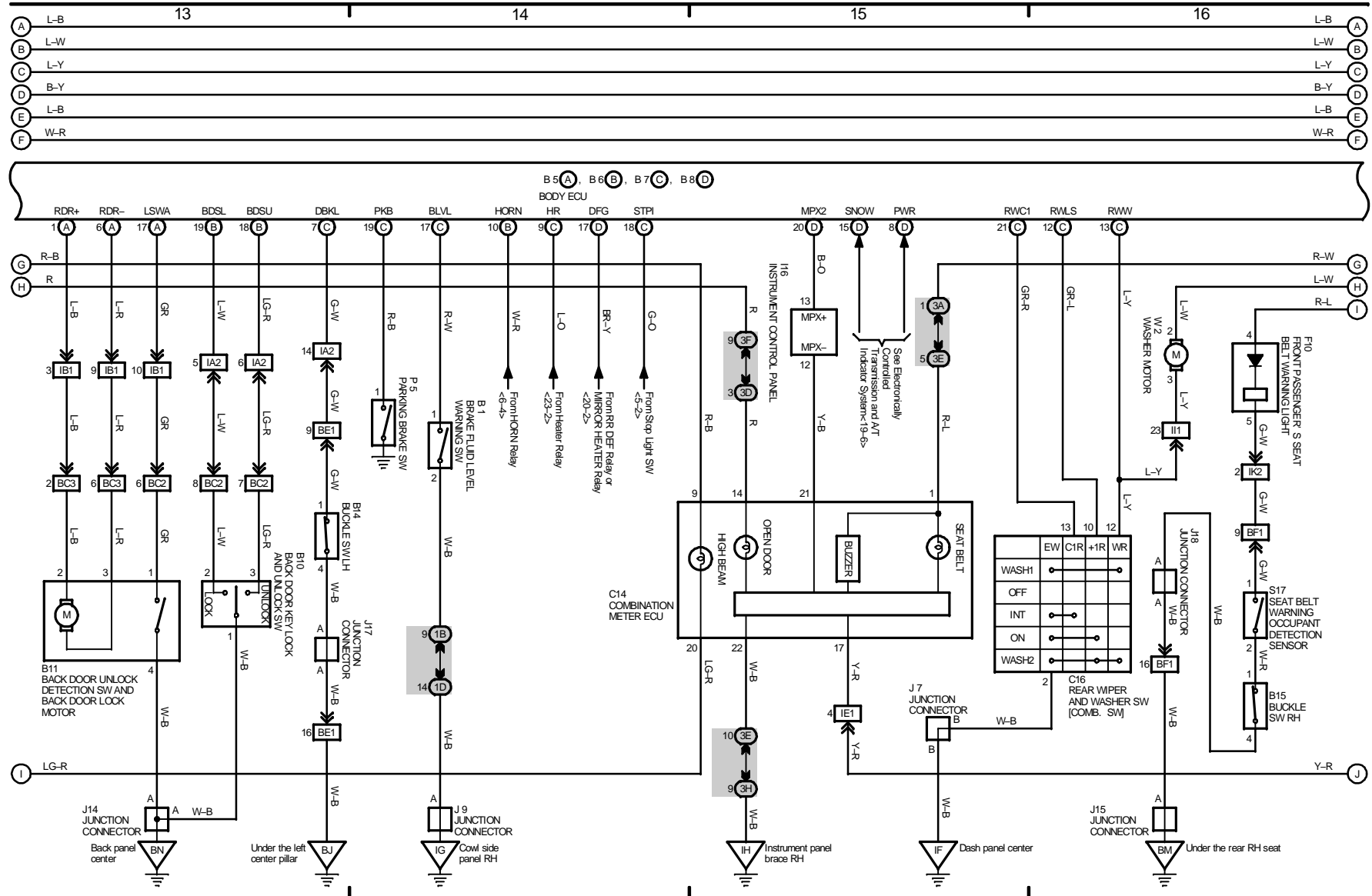

2000 LEXUS RX 300 (EWD395U)

Multiplex Communication System

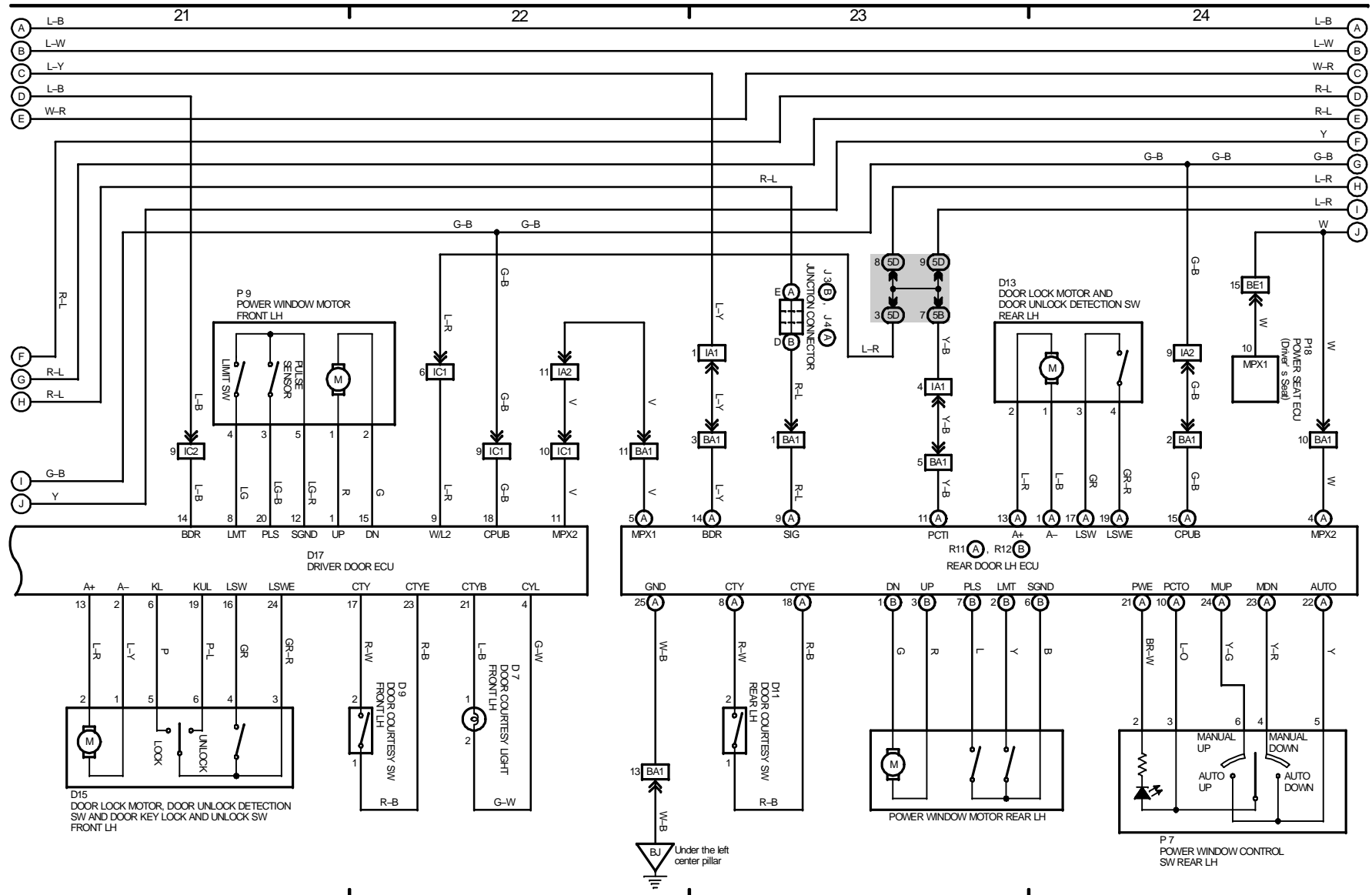

2000 LEXUS RX 300 (EWD395U)

Multiplex Communication System

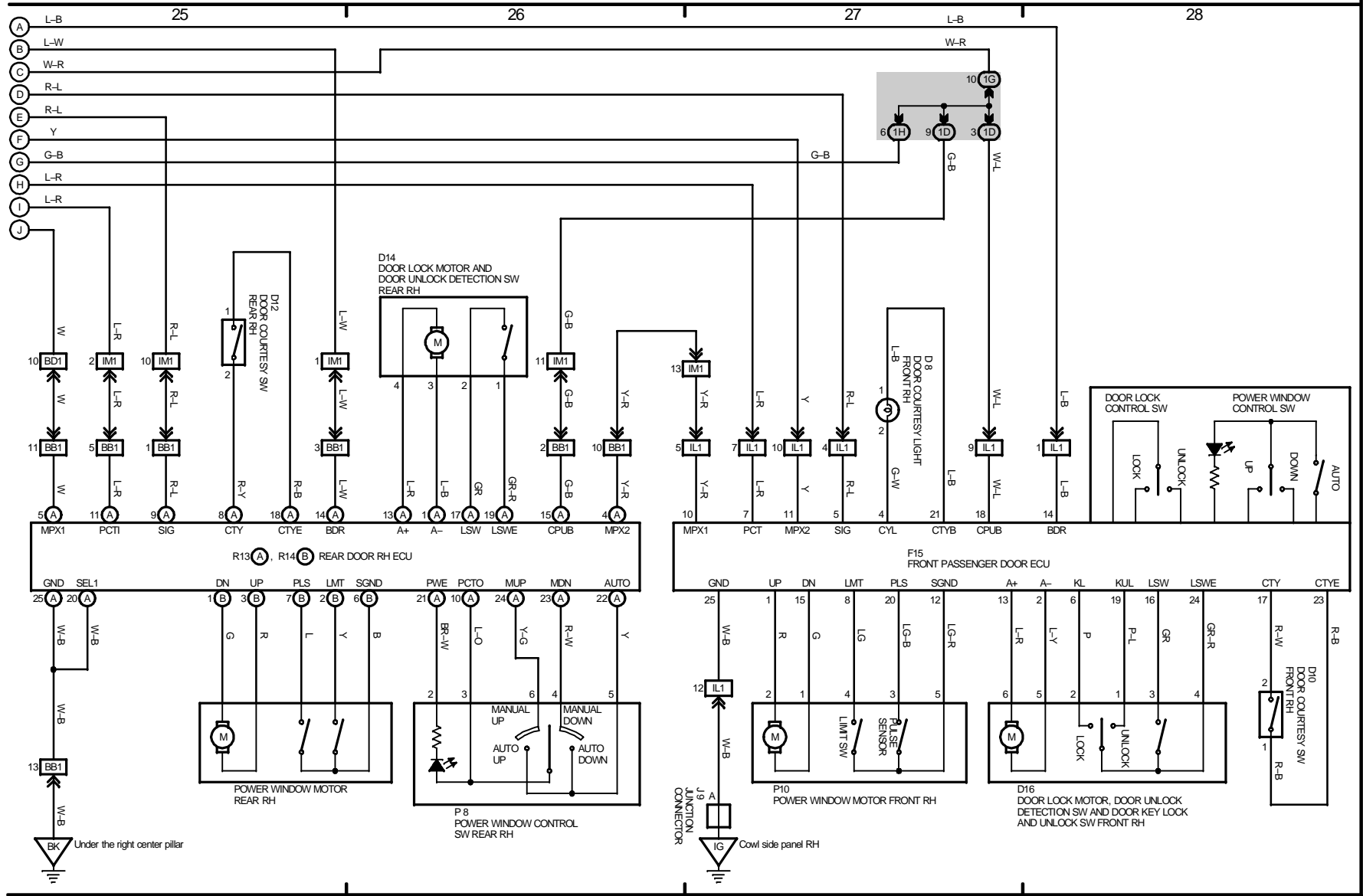

2000 LEXUS RX 300 (EWD395U)

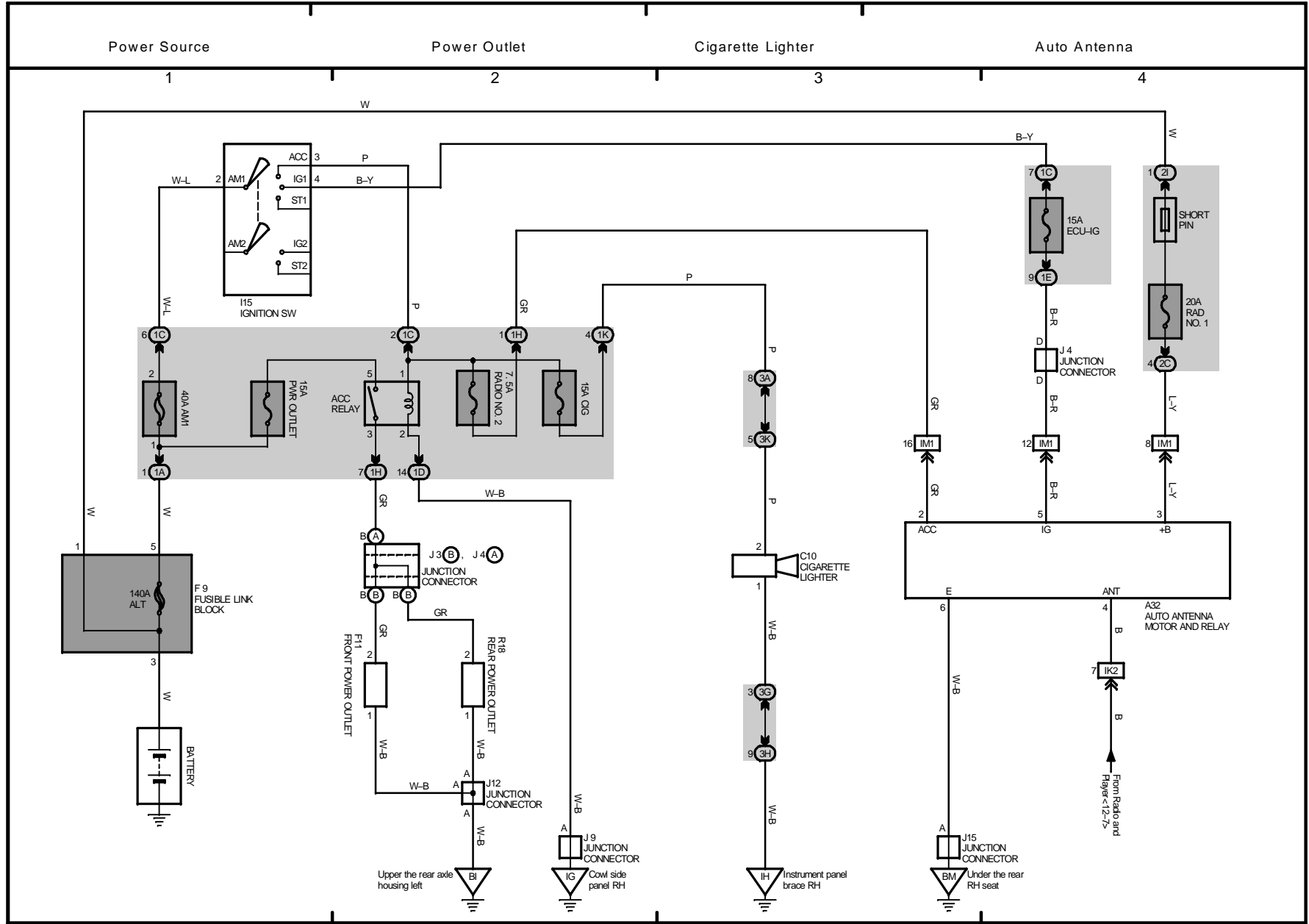

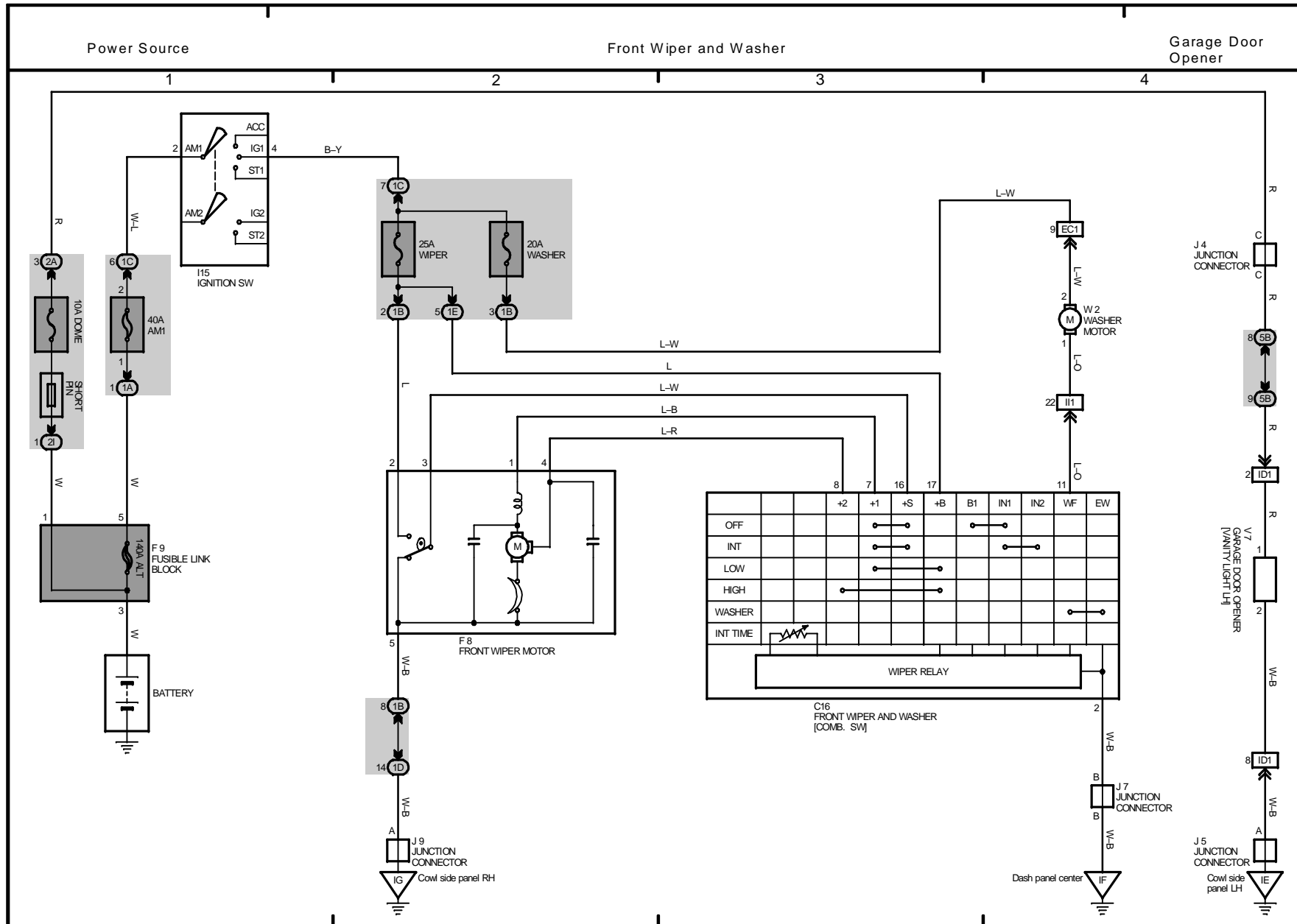

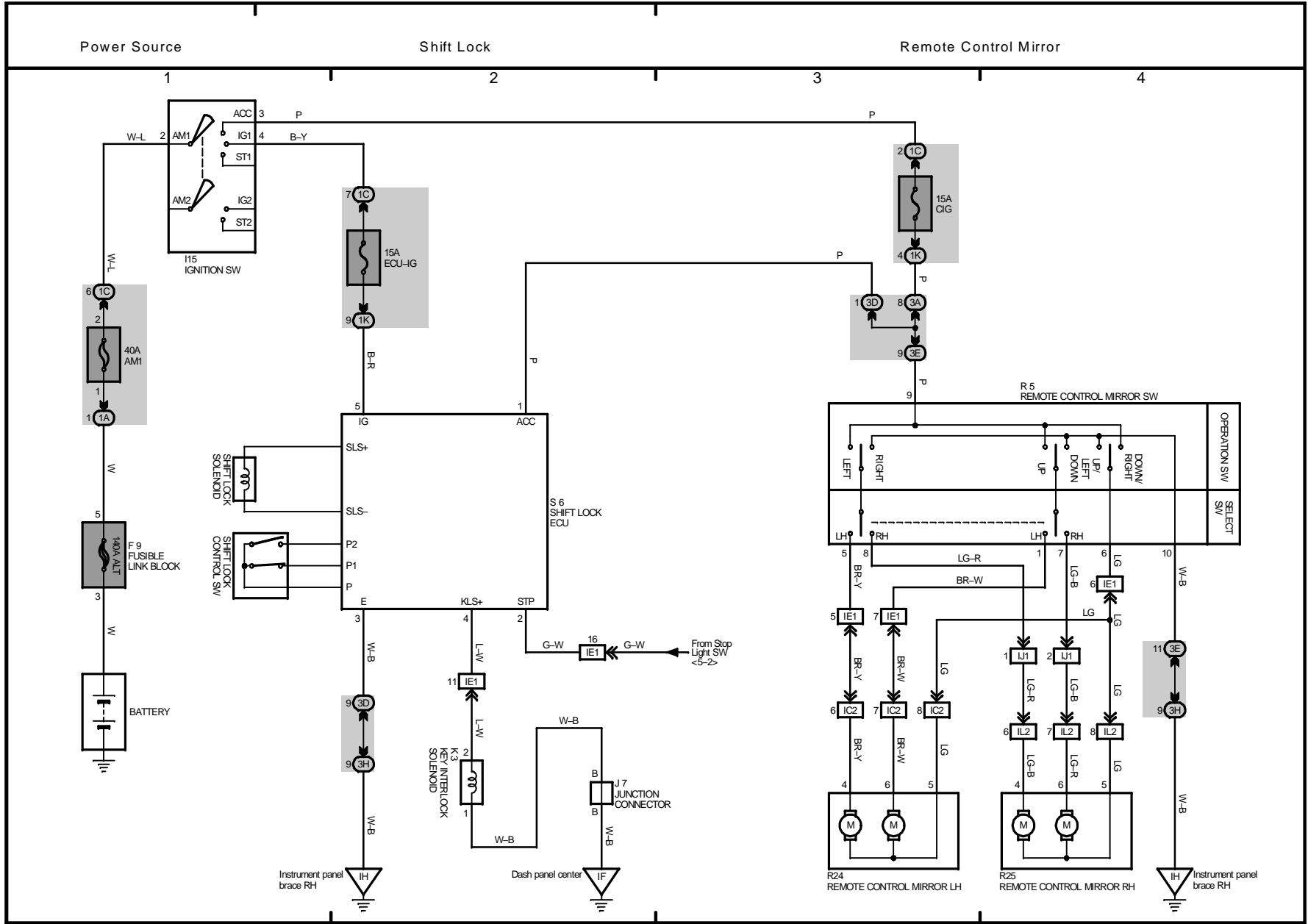

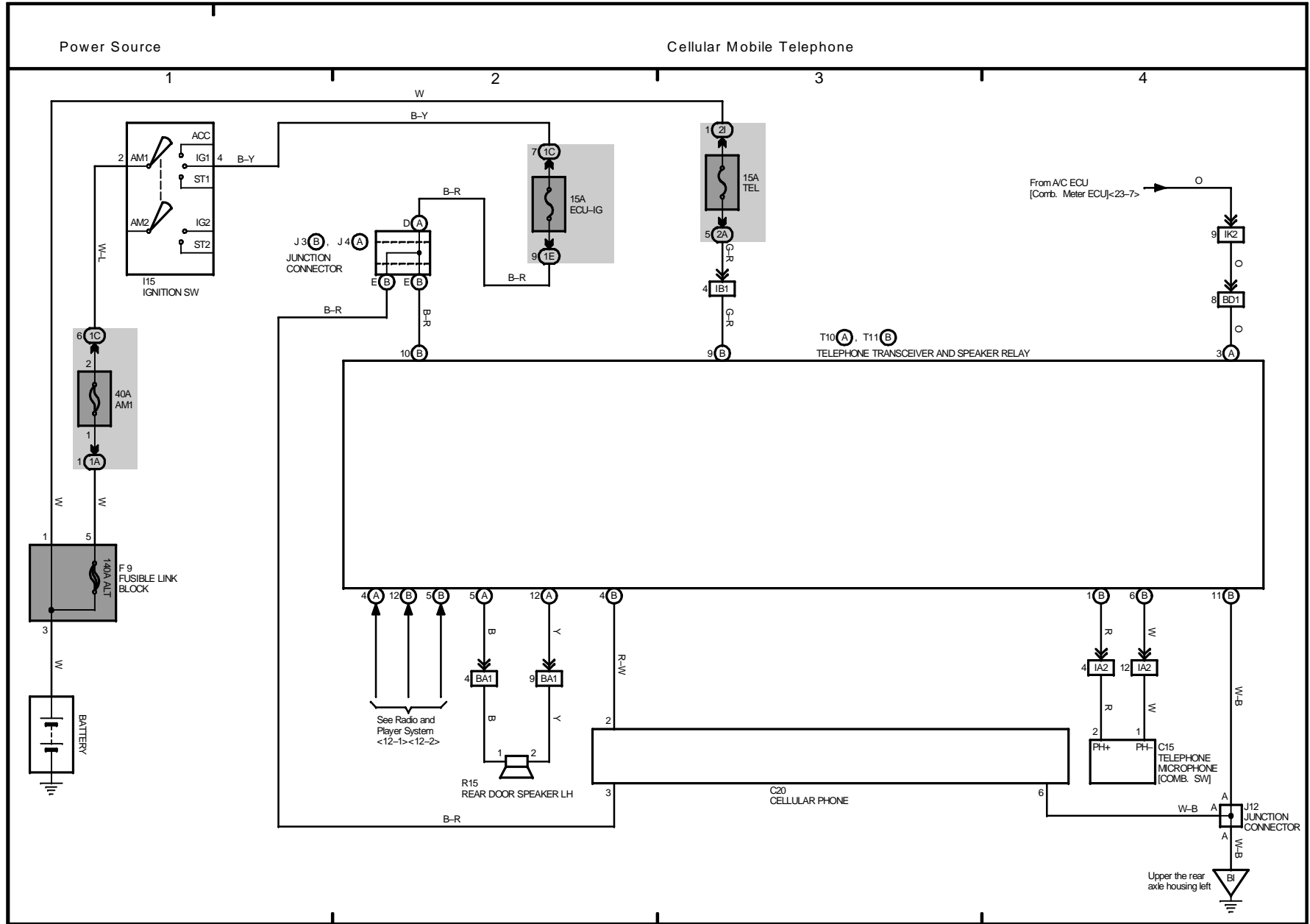

2000 LEXUS RX 300 (EWD395U)

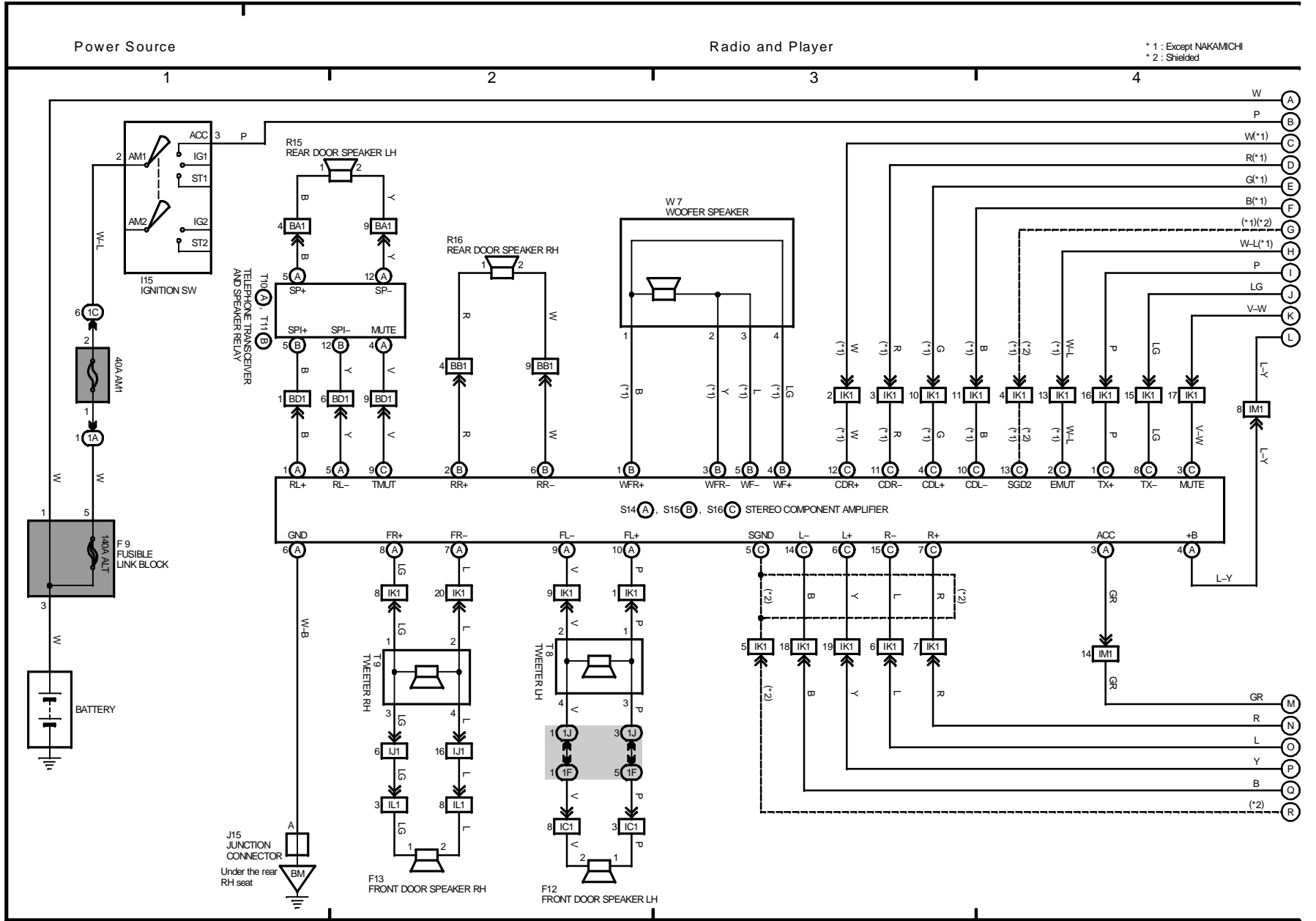

OVERALL ELECTRICAL WIRING DIAGRAM

Radio and Player

* 1 : Except NAKAMICHI
 * 2 : Shielded

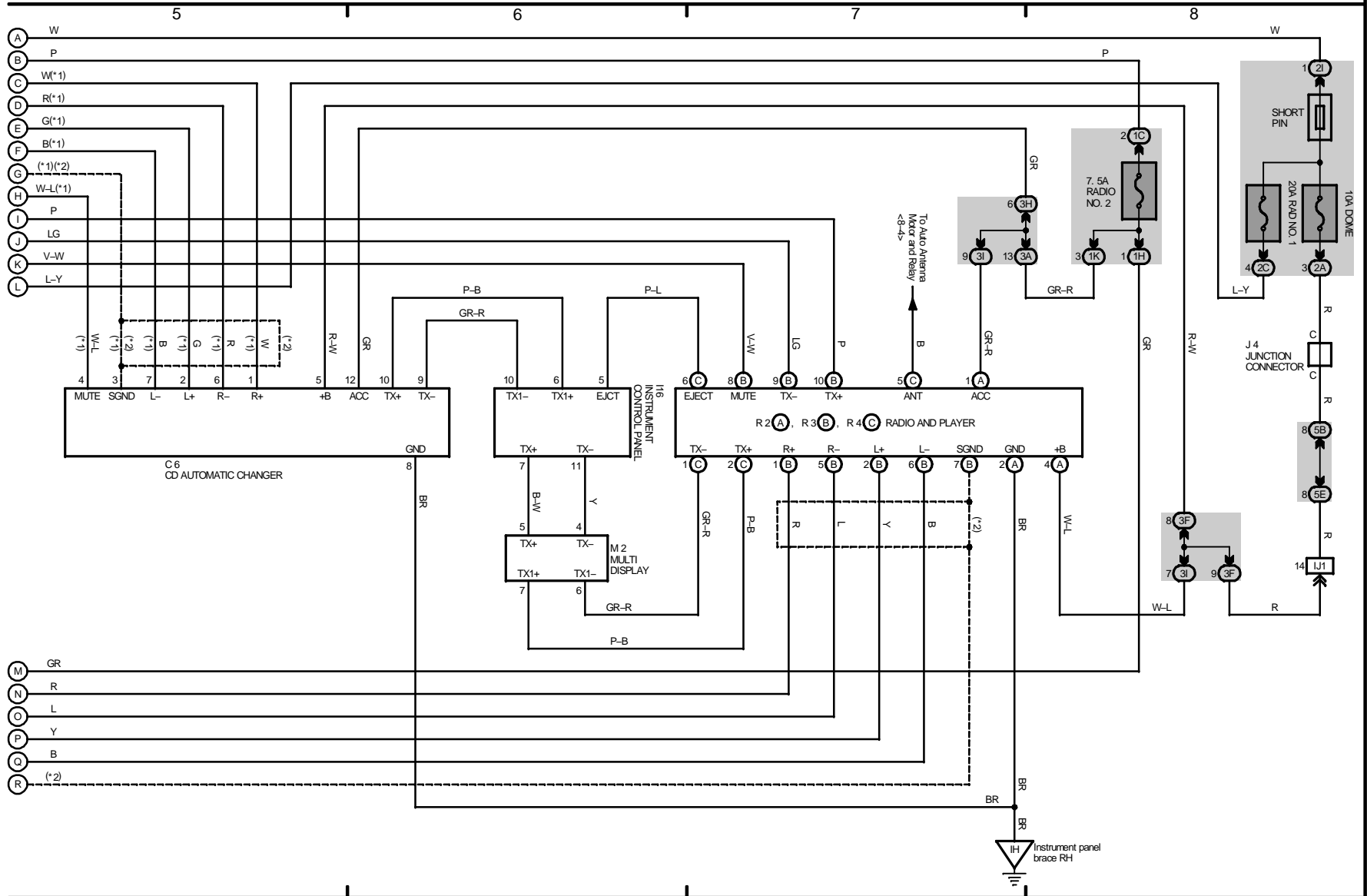

2000 LEXUS RX 300 (EWD395U)

M OVERALL ELECTRICAL WIRING DIAGRAM

13 RX 300

2000 LEXUS RX 300 (EWD395U)

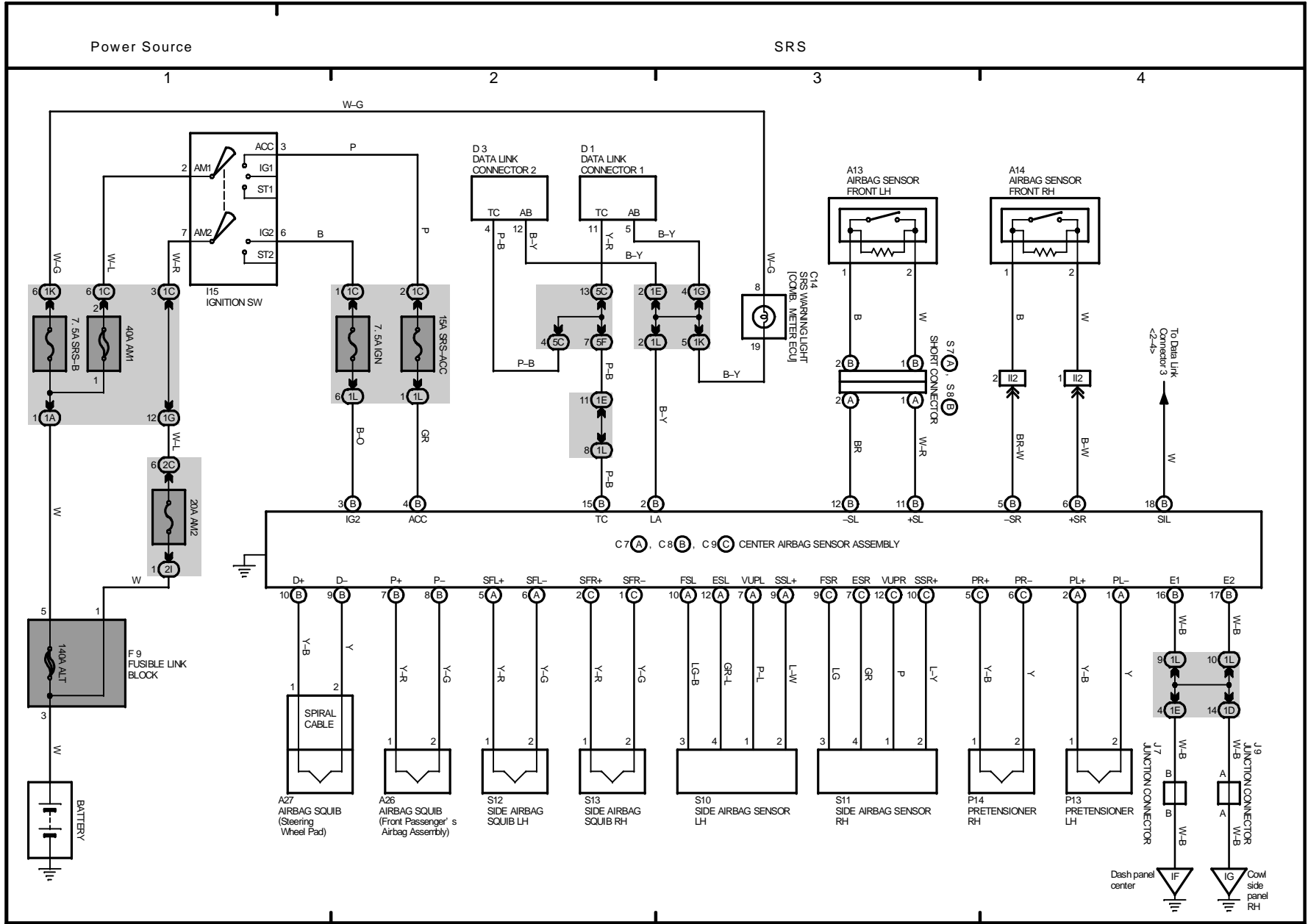

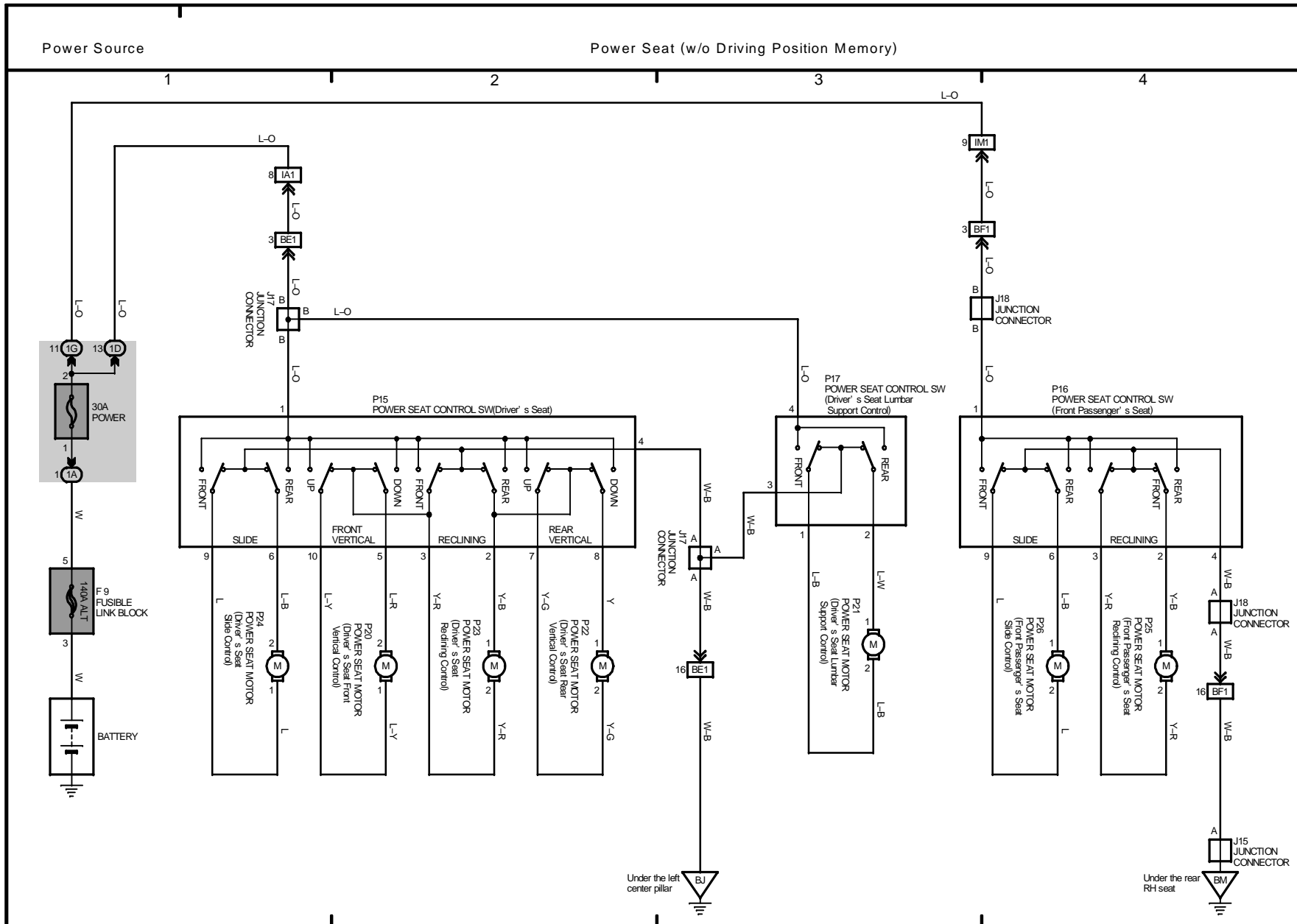

Power Seat (w/ Driving Position Memory)

Electric Tension Reducer

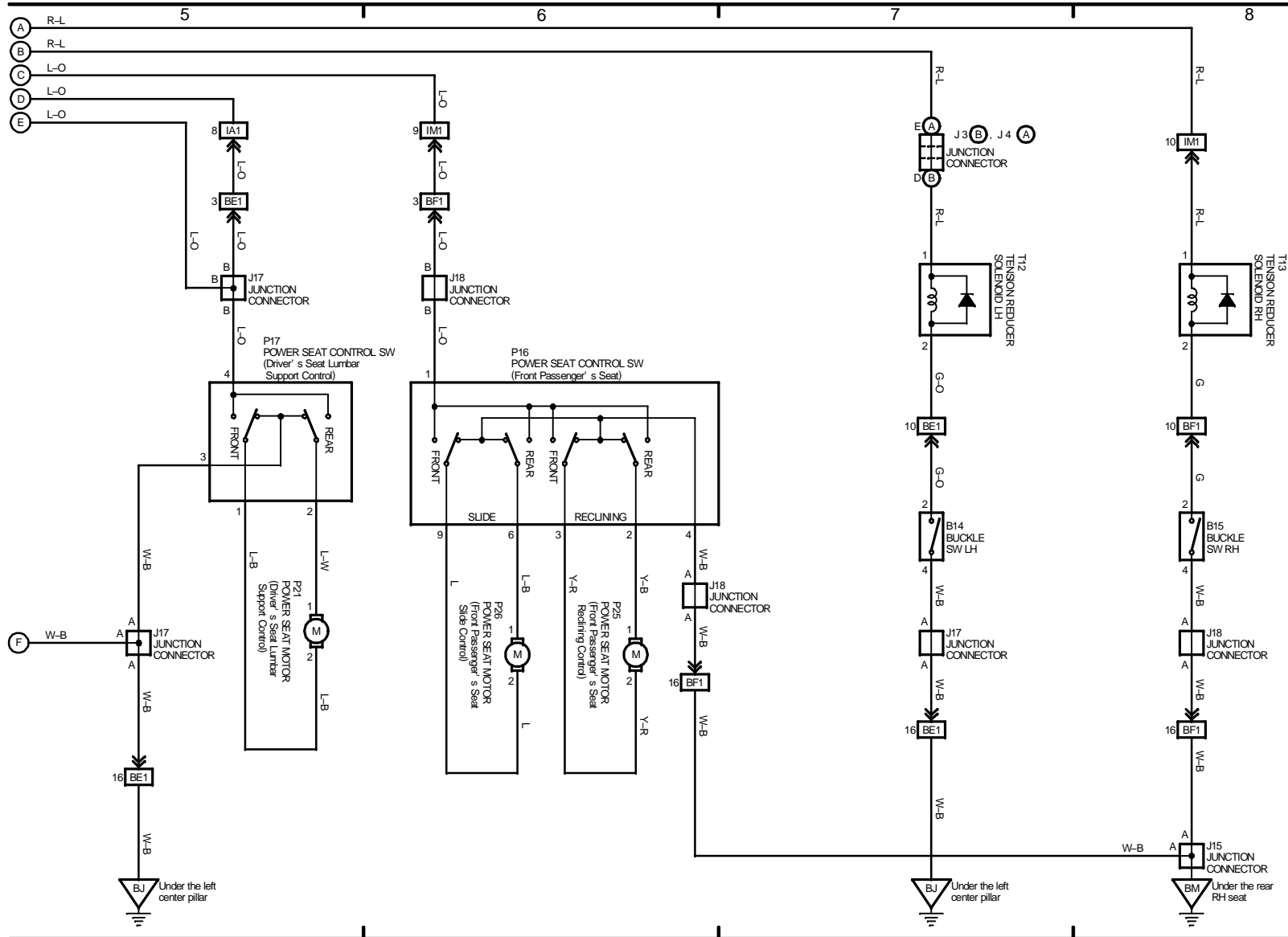

2000 LEXUS RX 300 (EWDP395U)

2000 LEXUS RX 300 (EWD395U)

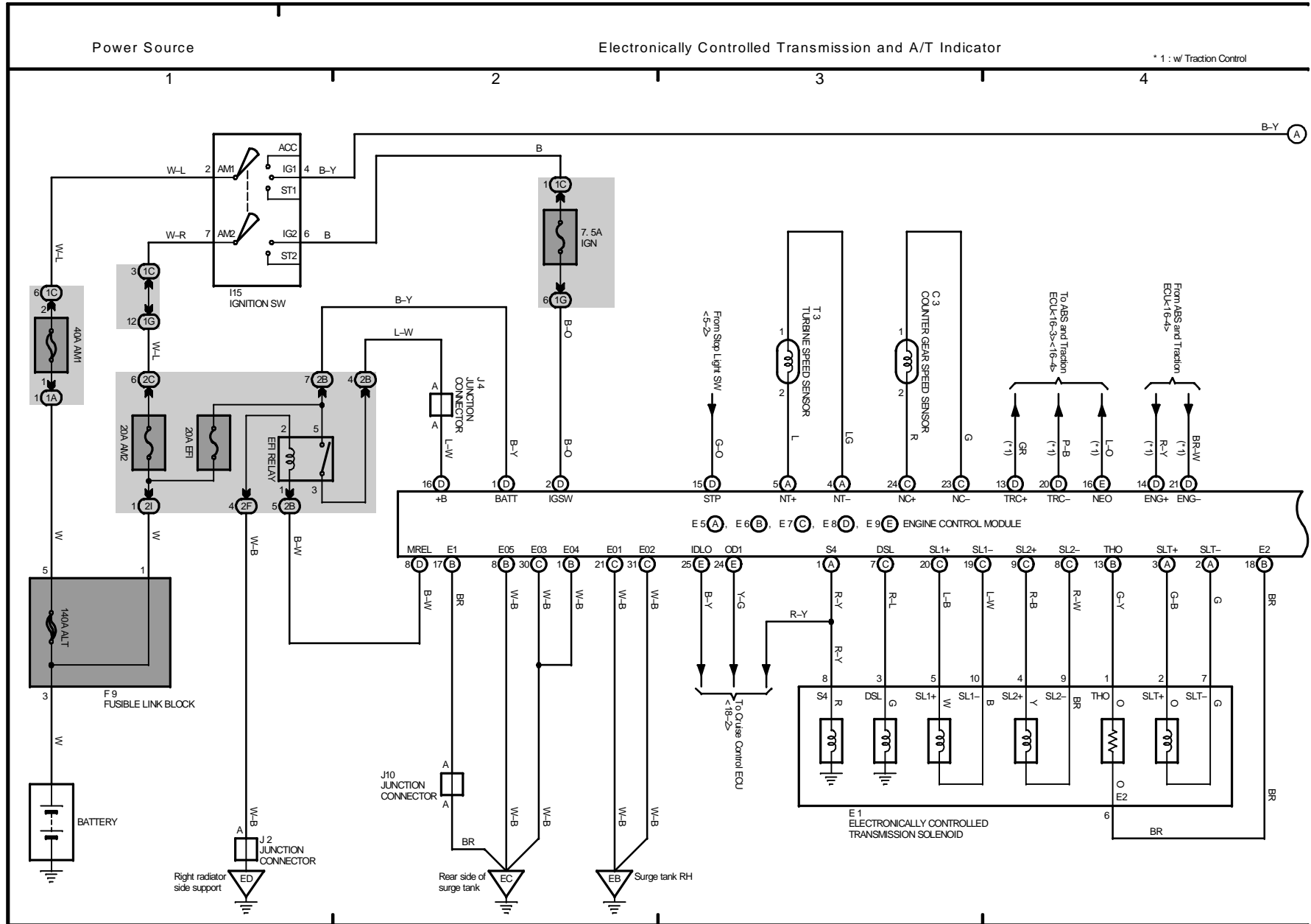

M OVERALL ELECTRICAL WIRING DIAGRAM

Electronically Controlled Transmission and A/T Indicator

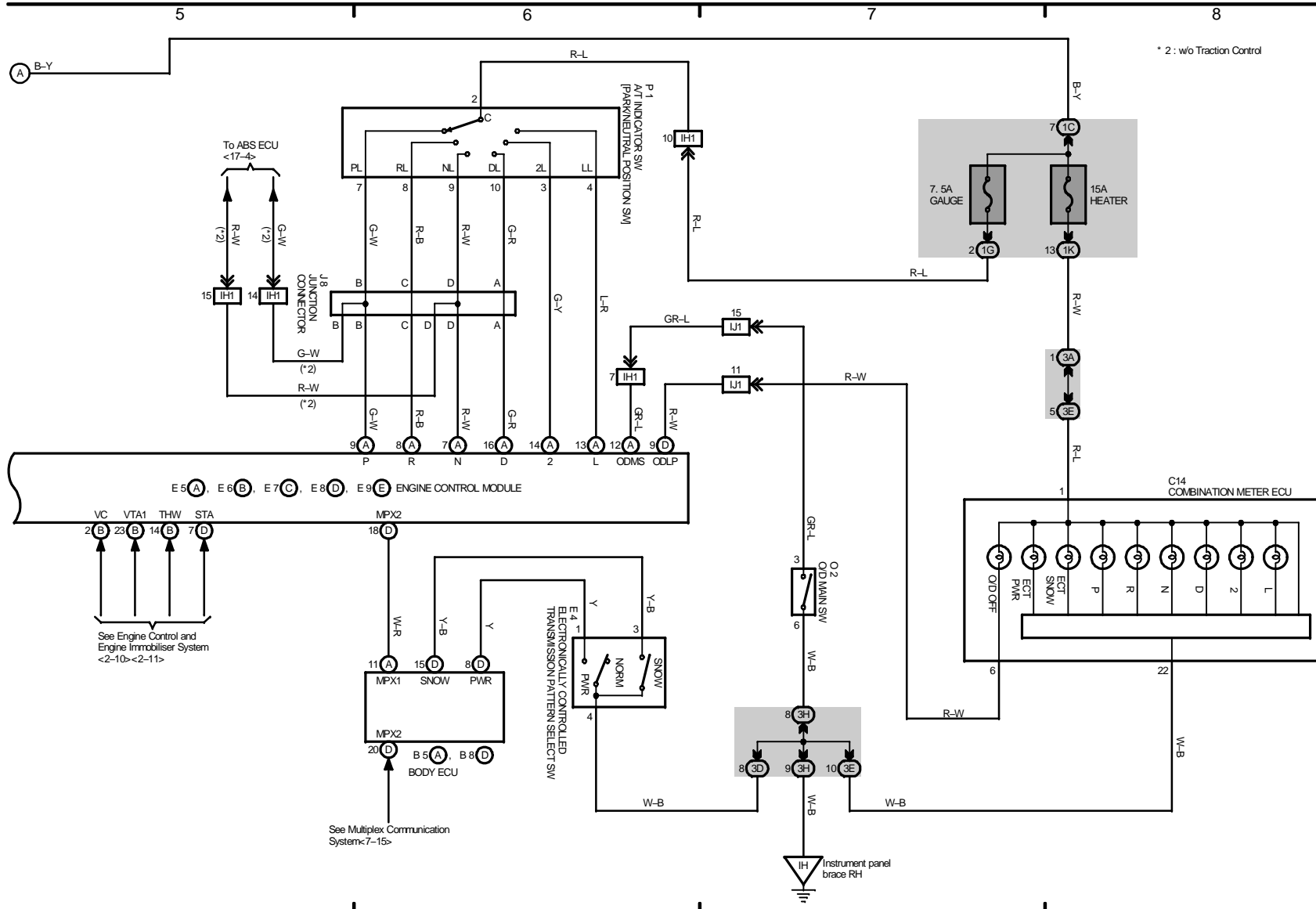

2000 LEXUS RX 300 (EWD395U)

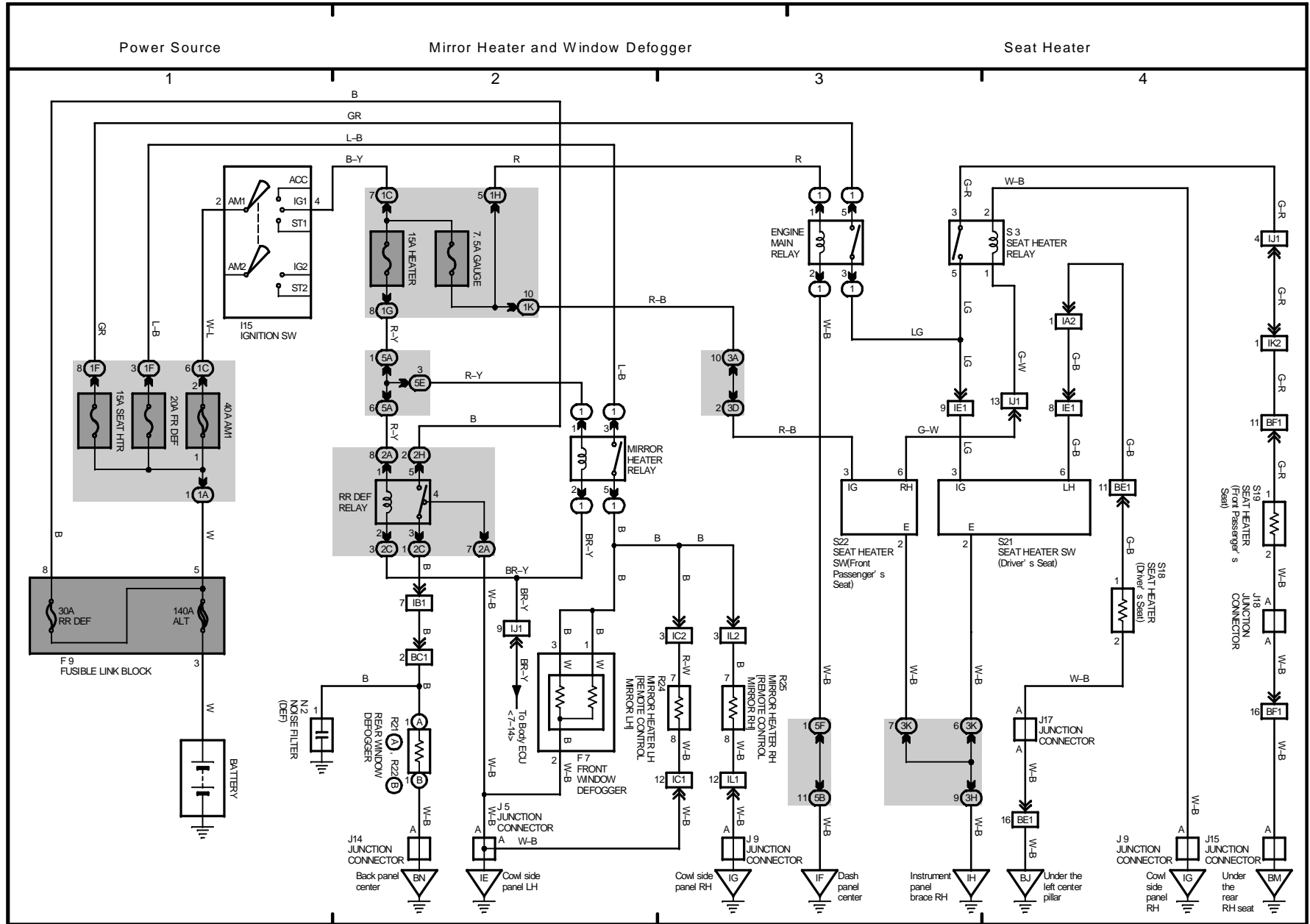

M OVERALL ELECTRICAL WIRING DIAGRAM

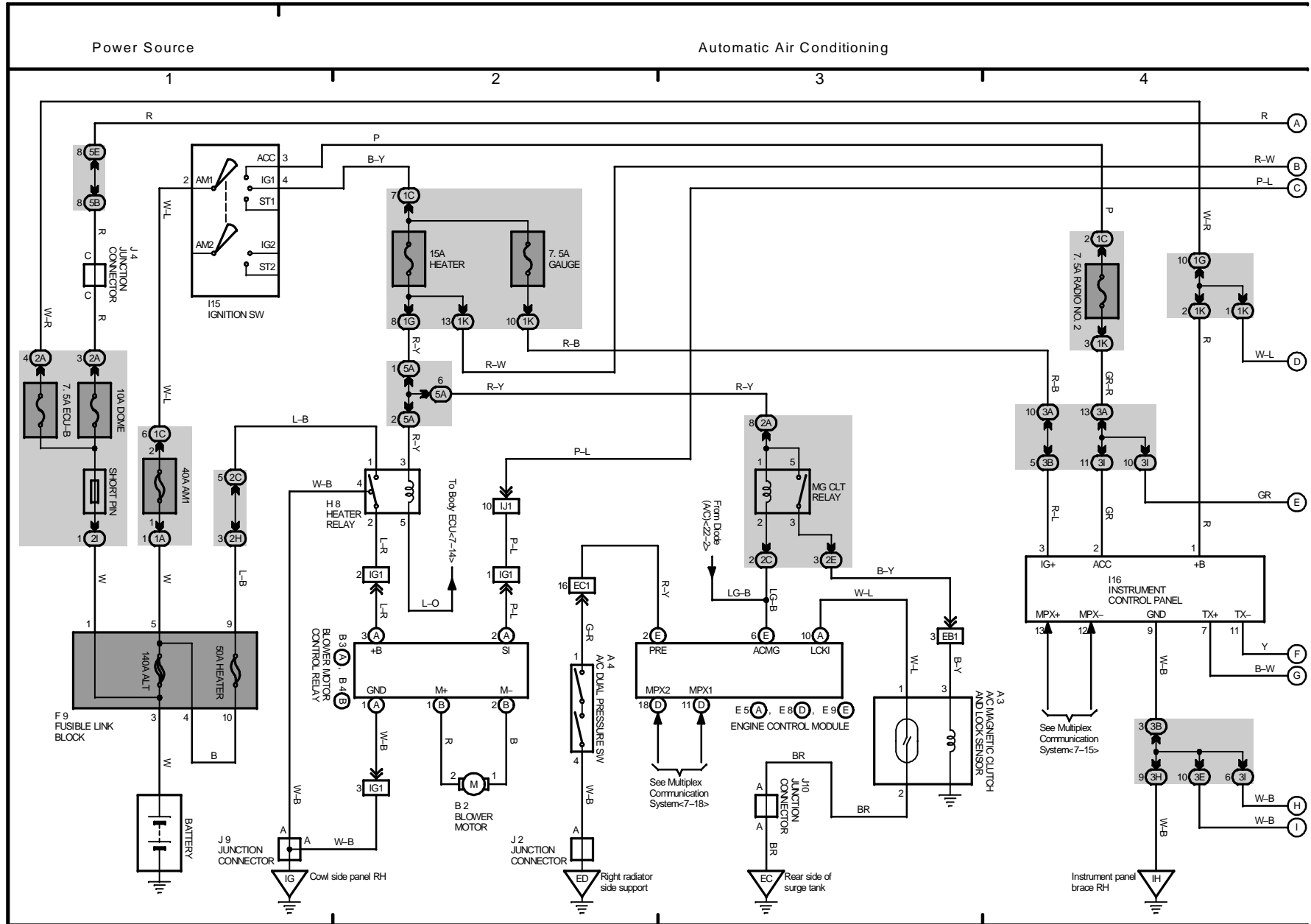

2000 LEXUS RX 300 (EWD395U)

