

RADIO AND PLAYER

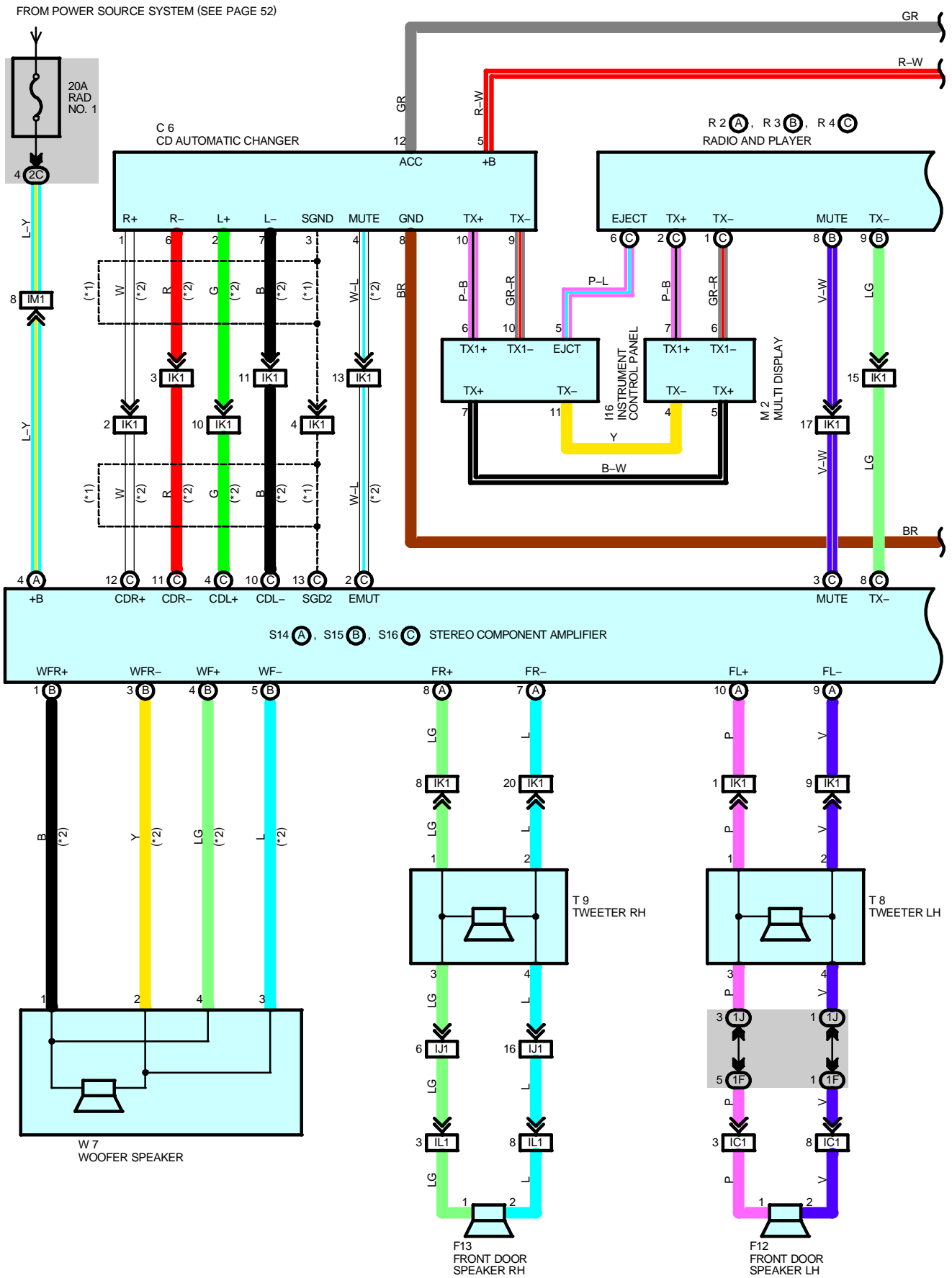

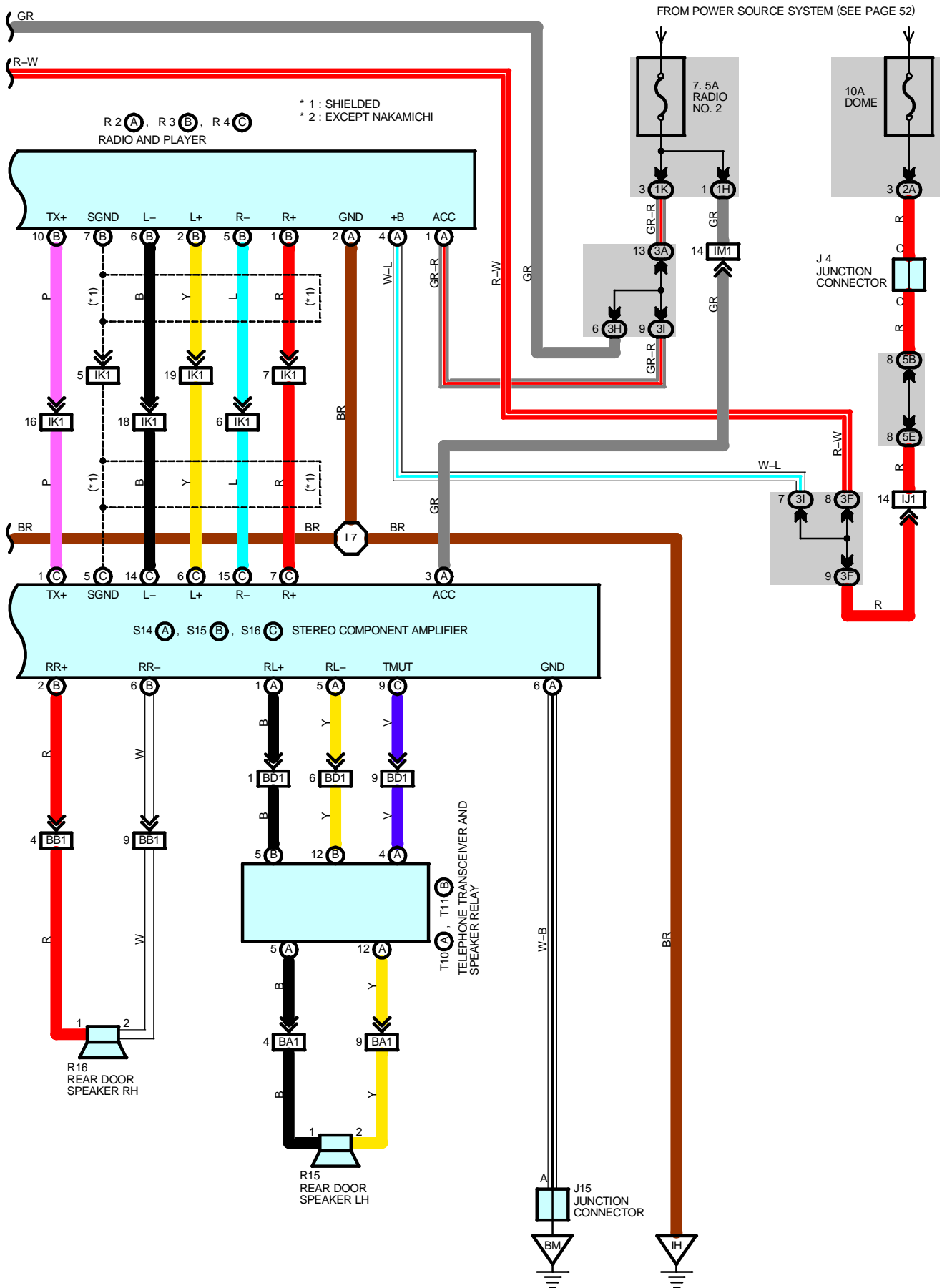

RADIO AND PLAYER

SERVICE HINTS

R2 (A) RADIO AND PLAYER

- (A) 1-GROUND : Approx. **12** volts with the ignition SW at **ACC** or **ON** position
- (A) 4-GROUND : Always approx. **12** volts
- (A) 2-GROUND : Always continuity

S14 (A) STEREO COMPONENT AMPLIFIER

- (A) 6-GROUND : Always continuity
- (A) 3-GROUND : Approx. **12** volts with the ignition SW at **ACC** or **ON** position
- (A) 4-GROUND : Always approx. **12** volts

○ : PARTS LOCATION

Code	See Page	Code	See Page	Code	See Page
C6	34	R2	A 35	S16	C 37
F12	36	R3	B 35	T8	35
F13	36	R4	C 35	T9	35
I16	35	R15	37	T10	A 37
J4	35	R16	37	T11	B 37
J15	36	S14	A 37	W7	37
M2	35	S15	B 37		

○ : JUNCTION BLOCK AND WIRE HARNESS CONNECTOR

Code	See Page	Junction Block and Wire Harness (Connector Location)
1F	22	Cowl Wire and Instrument Panel J/B (Lower Finish Panel)
1H		
1J	22	Instrument Panel Wire and Instrument Panel J/B (Lower Finish Panel)
1K		
2A	24	Cowl Wire and Engine Room J/B (Engine Compartment Left)
2C		
3A	26	Instrument Panel Wire and J/B No.3 (Behind the Instrument Panel Center)
3F		
3H		
3I		
5B	28	Cowl Wire and J/B No.5 (Behind the Instrument Panel Left)
5E		

□ : CONNECTOR JOINING WIRE HARNESS AND WIRE HARNESS

Code	See Page	Joining Wire Harness and Wire Harness (Connector Location)
IC1	42	Front Door LH Wire and Cowl Wire (Left Kick Panel)
IJ1	44	Cowl Wire and Instrument Panel Wire (Behind the Glove Box)
IK1	44	Floor Wire and Instrument Panel Wire (Behind the Glove Box)
IL1	44	Front Door RH Wire and Cowl Wire (Right Kick Panel)
IM1	44	Cowl Wire and Floor Wire (Right Kick Panel)
BA1	46	Rear Door LH Wire and Floor No.2 Wire (Under the Left Center Pillar)
BB1	46	Rear Door RH Wire and Floor Wire (Under the Right Center Pillar)
BD1	46	Floor No.2 Wire and Floor Wire (Upper the Rear Axle Housing Left)

▽ : GROUND POINTS

Code	See Page	Ground Points Location
IH	42	Instrument Panel Brace RH
BM	46	Under the Rear RH Seat

○ : SPLICE POINTS

Code	See Page	Wire Harness with Splice Points	Code	See Page	Wire Harness with Splice Points
I7	44	Instrument Panel Wire			

