

Mazzuri Super

12780 Pierce St. #8 Pacoima, CA 91331

Tel: (818) 897-4687

Fax: (323) 843-9535

<http://www.mazzurisuper.com>

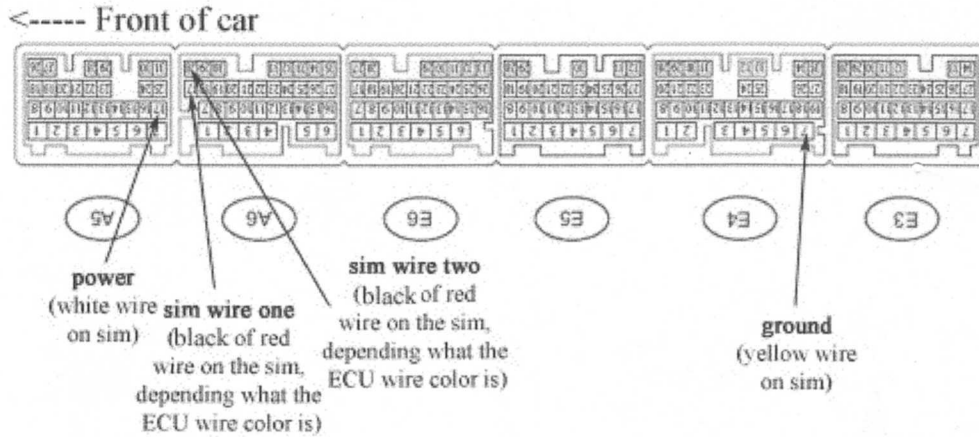

DISCONNECT GROUND WIRE BEFORE INSTALLING SIM

Some install tips:

1. This is not an easy install; make sure you know what you are doing.
2. The oil dipstick will be in the way of the header, when you unbolt the bolts holding it in place the header will fit. If you want to bolt it back up, you will need to modify the lower bracket, if you don't want to, you can just zip tie it.
3. MAKE SURE TO LEAVE EVERYTHING LOSE, DON'T TIGHTEN ANYTHING UNTILL ALL THE BOLTS AND NUTS ARE ONE. THAN WORK YOUR WAY FROM THE BOTTOM UP.
4. Reuse all the stock gaskets. To keep the stock donut gasket in place while you're bolting it up to the new header, put something sticky on it (I use exhaust gasket maker) and it won't move.
5. Unclipping the o2 sensor plugs, is done from the bottom of the car when you are pulling out the stock headers.
6. Do not splice the 2 o2 sensor wires back in to the connection. Just cut them and attach the new O2 sim wires and leave the original ones cut.