

REMOVAL

1. REMOVE THESE PARTS:

- (a) Front door scuff plates
- (b) Cowl side trims
- (c) Front door opening trims
- (d) Assist grips
- (e) Front pillar garnishes

2. REMOVE STEERING WHEEL

(See page [SR-12](#))

3. REMOVE CLUSTER FINISH PANEL

Using a screwdriver, remove the cluster finish panel.

HINT:

Tape the screwdriver tip before use.

4. REMOVE HOOD LOCK AND FUEL LID CONTROL CABLE LEVER

- (a) Remove the 2 screws and hood lock control cable.
- (b) Remove the 2 screws and fuel lid control cable lever.

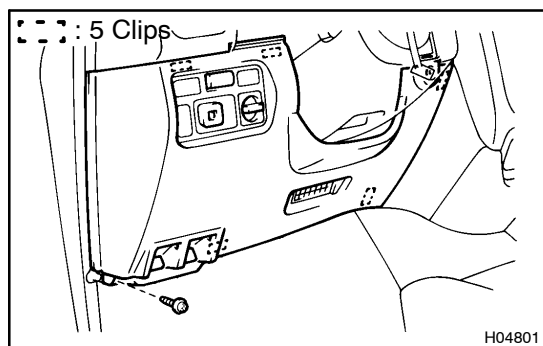
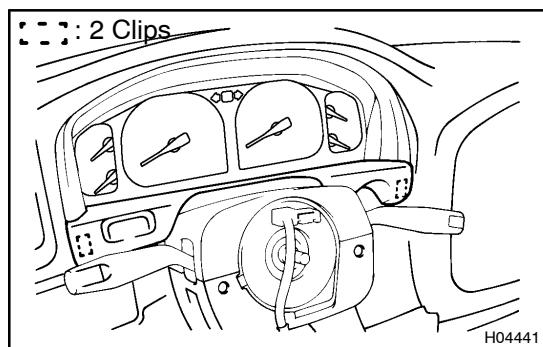

5. REMOVE LOWER NO.1 PANEL

- (a) Remove the screw.
- (b) Using a screwdriver, remove the lower No.1 panel, then disconnect the connectors.

HINT:

Tape the screwdriver tip before use.

6. REMOVE LH LOWER PANEL

7. REMOVE COLUMN COVER

Remove the 3 screws and column cover.

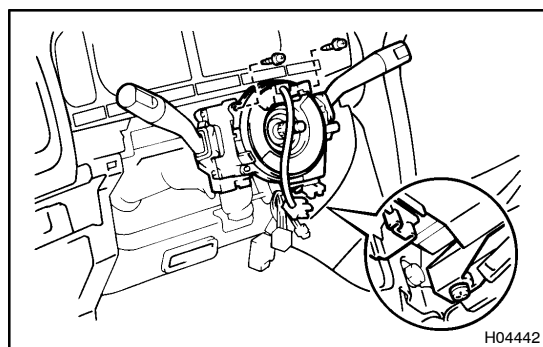

8. REMOVE COMBINATION SWITCH

- (a) Disconnect the connectors.
- (b) Remove the clamp.
- (c) Remove the 3 screws and combination switch.

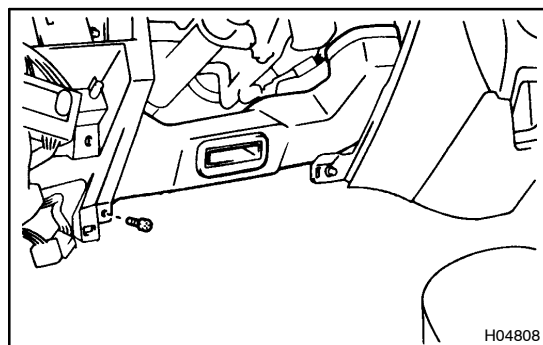

9. REMOVE NO.2 HEATER TO REGISTER DUCT

Remove the screw and No.2 heater to register duct as shown in the illustration.

10. REMOVE STEERING COLUMN

(See page [SR-12](#))

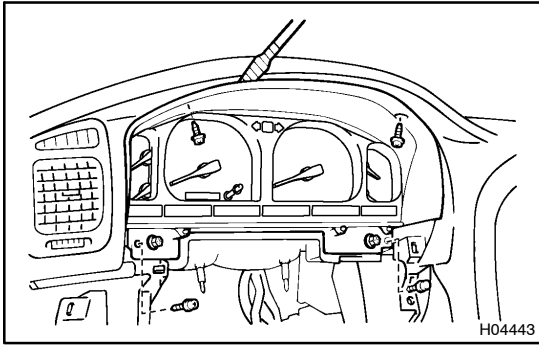

11. REMOVE COMBINATION METER

- (a) Disconnect the connectors.

HINT:

The connectors can be disconnected by loosening the bolts.

- (b) Remove the 2 screws and bolts.

- (c) Using a screwdriver, remove the combination meter.

HINT:

Tape the screwdriver tip before use.

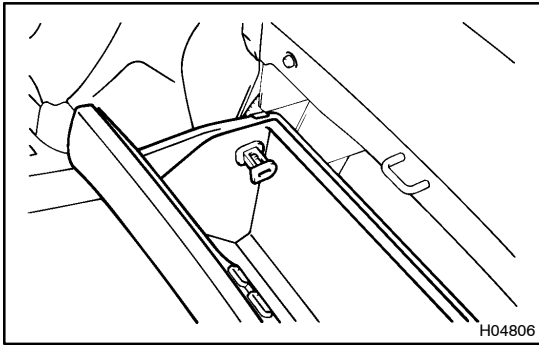

12. REMOVE GLOVE COMPARTMENT DOOR

- (a) Remove the glove compartment door stoppers.

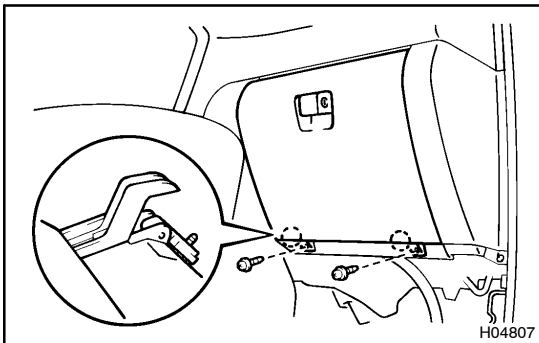

- (b) Remove the 2 screws and glove compartment door as shown in the illustration.

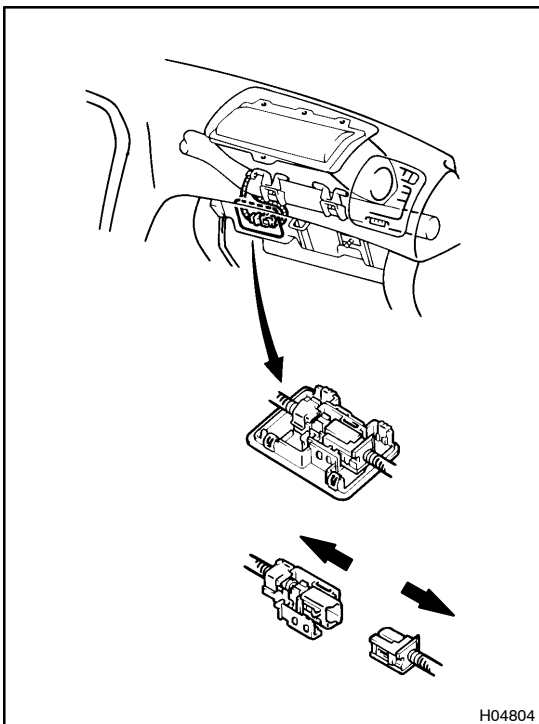

13. DISCONNECT AIRBAG CONNECTOR

(See page [RS-25](#))

- (a) Using a screwdriver, remove the No.1 under cover.

HINT:

Tape the screwdriver tip before use.

- (b) Pull up the airbag connector from the No.1 under cover.

- (c) Disconnect the airbag connector.

NOTICE:

When handling the airbag connector, take care not to damage the airbag wire harness.

14. REMOVE LOWER NO.2 PANEL

Remove the 3 screws and lower No.2 panel.

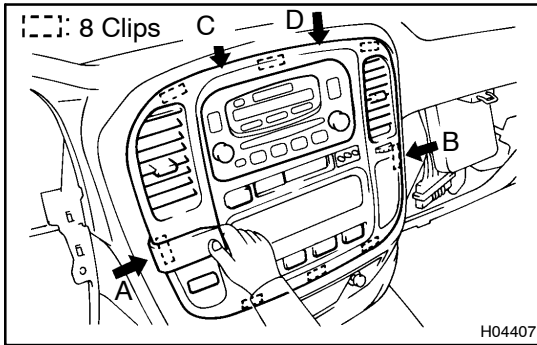
**15. REMOVE CENTER CLUSTER**

- (a) Using a moulding remover, remove the center cluster in order "A", "B", "C", "D" as shown in the illustration.
- (b) Disconnect the connectors.

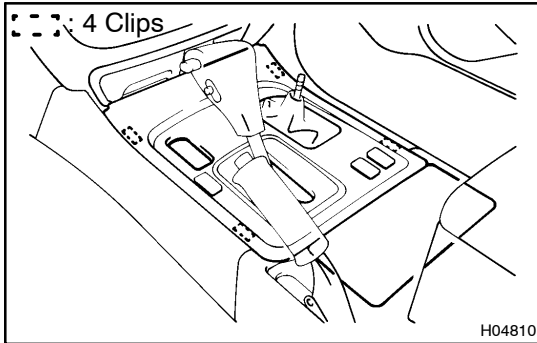
16. REMOVE RADIO ASSEMBLY**17. REMOVE REAR CONSOLE PANEL**

- (a) Remove the transfer shift lever knob.
- (b) Using a screwdriver, remove the rear console panel.

HINT:

Tape the screwdriver tip before use.

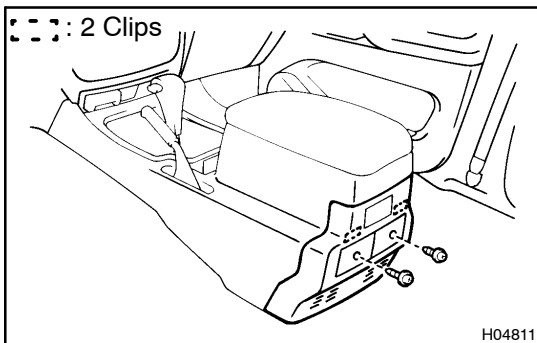
**18. REMOVE CONSOLE REAR END PANEL**

- (a) Remove the 2 screws.
- (b) Using a screwdriver, remove the console rear end panel.

HINT:

Tape the screwdriver tip before use.

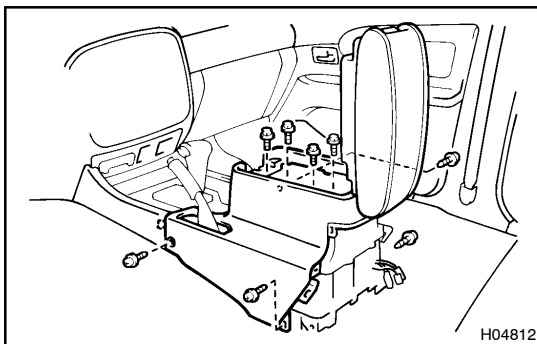
**19. REMOVE REAR CONSOLE BOX**

Remove the 4 bolts, 4 screws and rear console box.

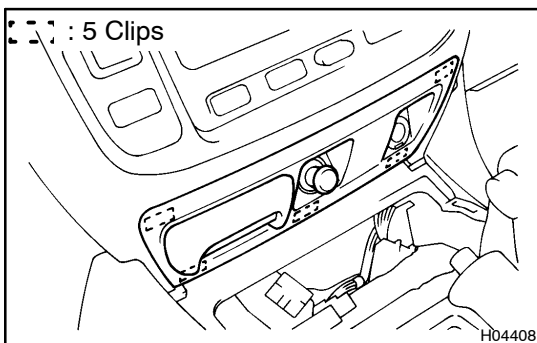
**20. REMOVE CENTER LOWER CLUSTER FINISH PANEL**

Using a screwdriver, remove the center lower cluster finish panel, then disconnect the connector.

HINT:

Tape the screwdriver tip before use.

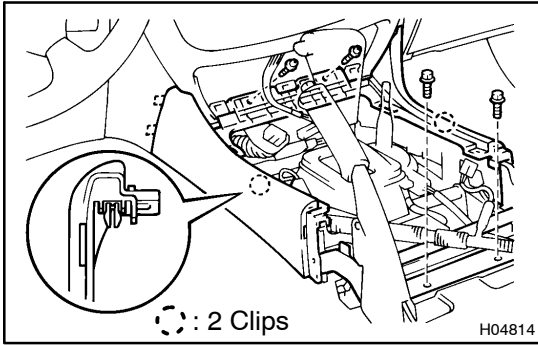
**21. REMOVE FRONT CONSOLE BOX**

Remove the 2 screws, 2 bolts and front console box.

22. REMOVE INSTRUMENT PANEL

(a) Disconnect the junction connectors.

HINT:

The connectors can be disconnected by loosening the bolts.

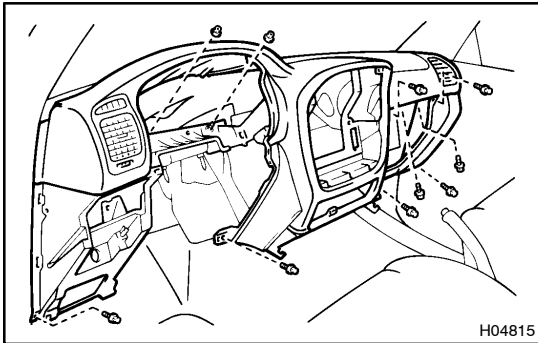

(b) Disconnect the connector, then remove the 8 bolts, 2 nuts and instrument panel.

23. REMOVE THESE PARTS:

- (a) Engine control ECU
- (b) No.3 heater to register duct
- (c) No.4 heater to register duct
- (d) Floor brace
- (e) No.1 brace
- (f) Reinforcement