

# Audio System

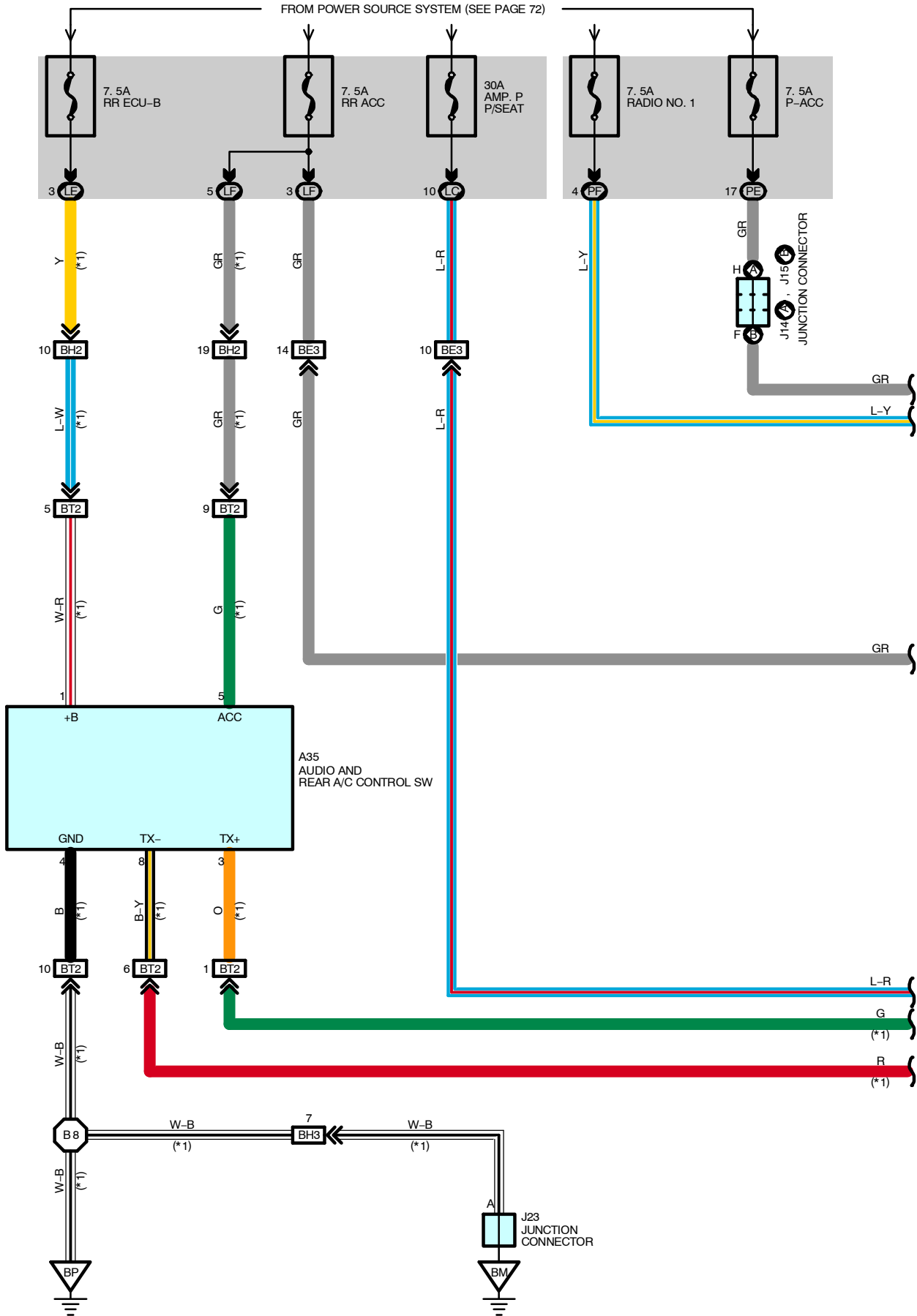

- \* 1 : W/ REAR AUDIO CONTROLLER
- \* 2 : MARK LEVINSON
- \* 3 : EXCEPT \*2

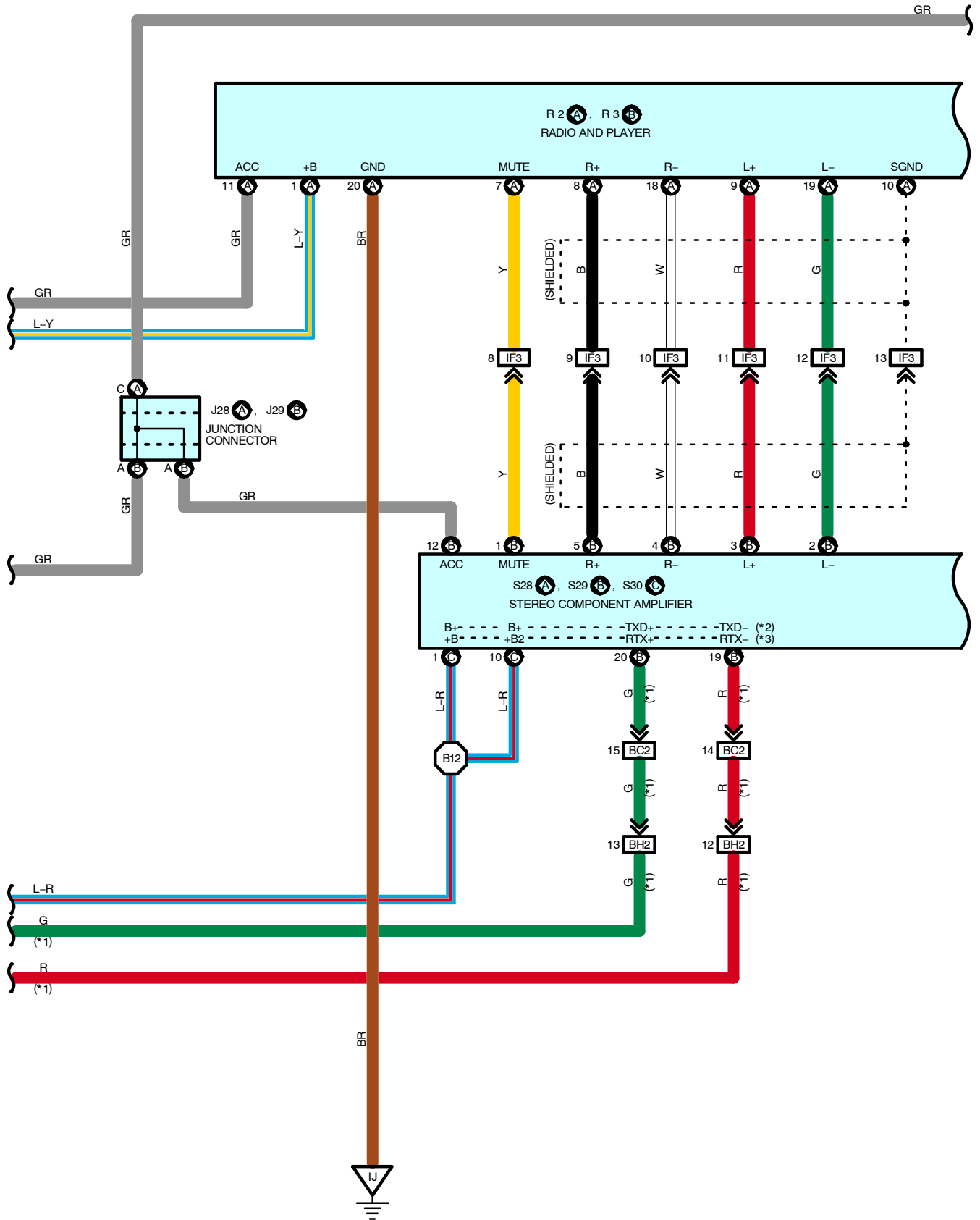

# Audio System

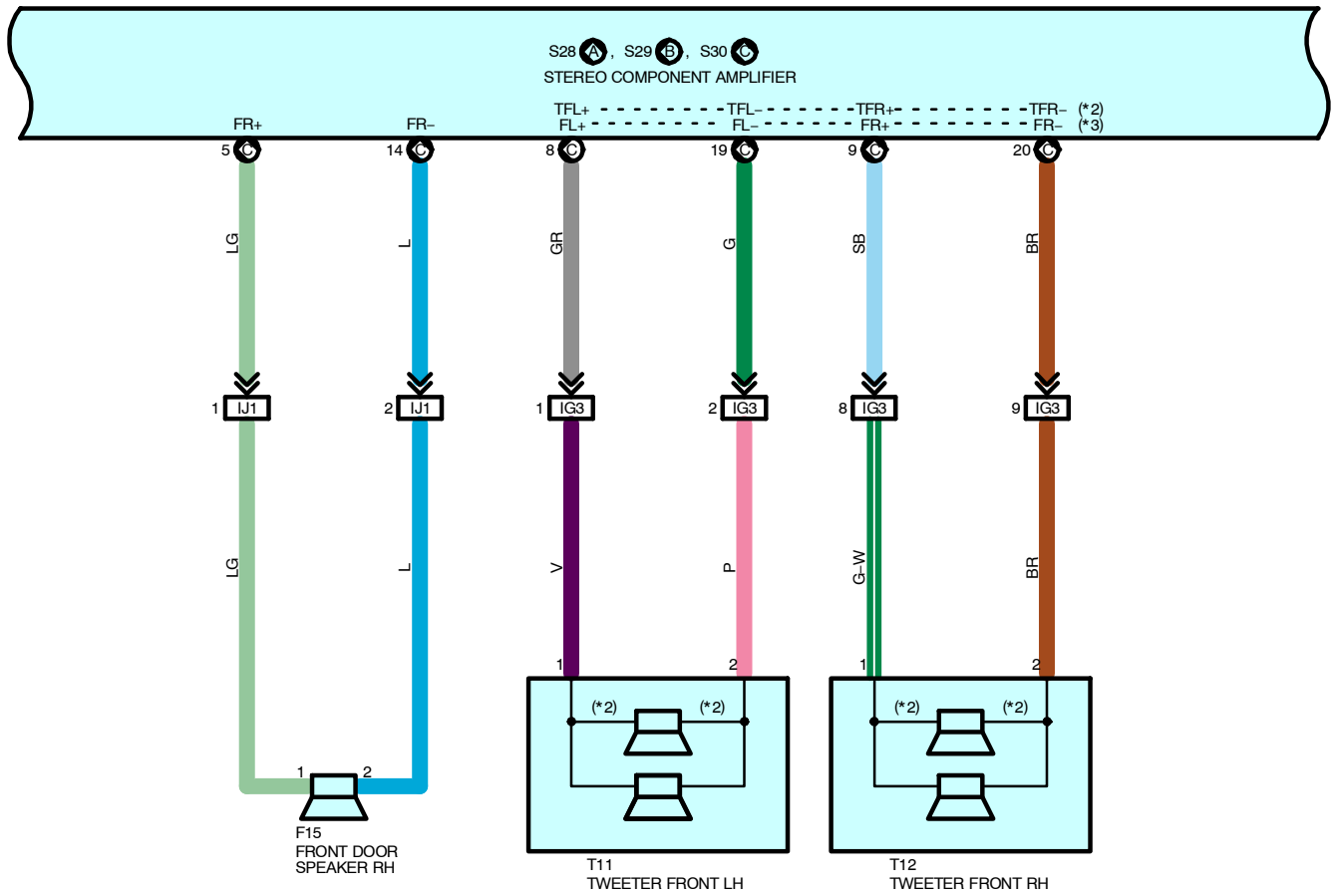
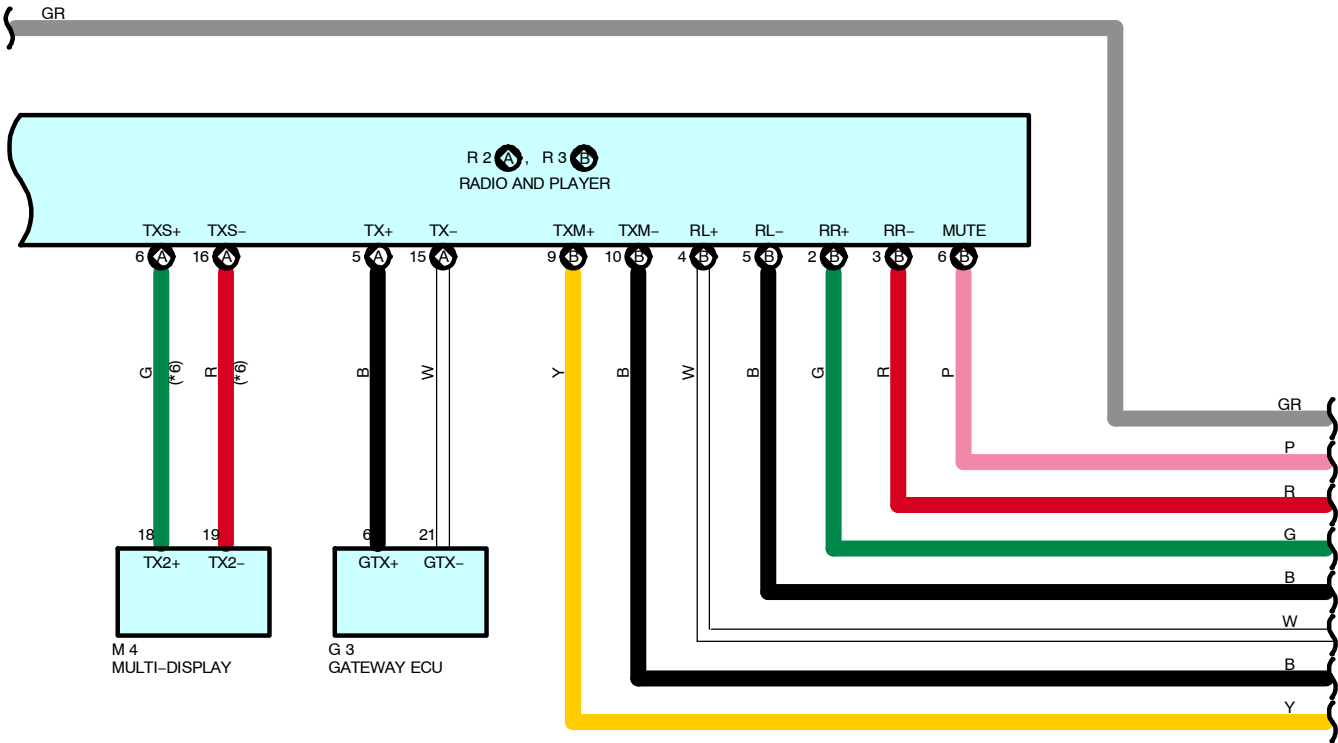

FROM POWER SOURCE SYSTEM (SEE PAGE 72)

- \* 2 : MARK LEVINSON
- \* 3 : EXCEPT \*2
- \* 4 : EXCEPT 7 SPEAKER
- \* 5 : 7 SPEAKER
- \* 6 : W/ LEXUS NAVIGATION SYSTEM

S31  
STEREO COMPONENT TUNER

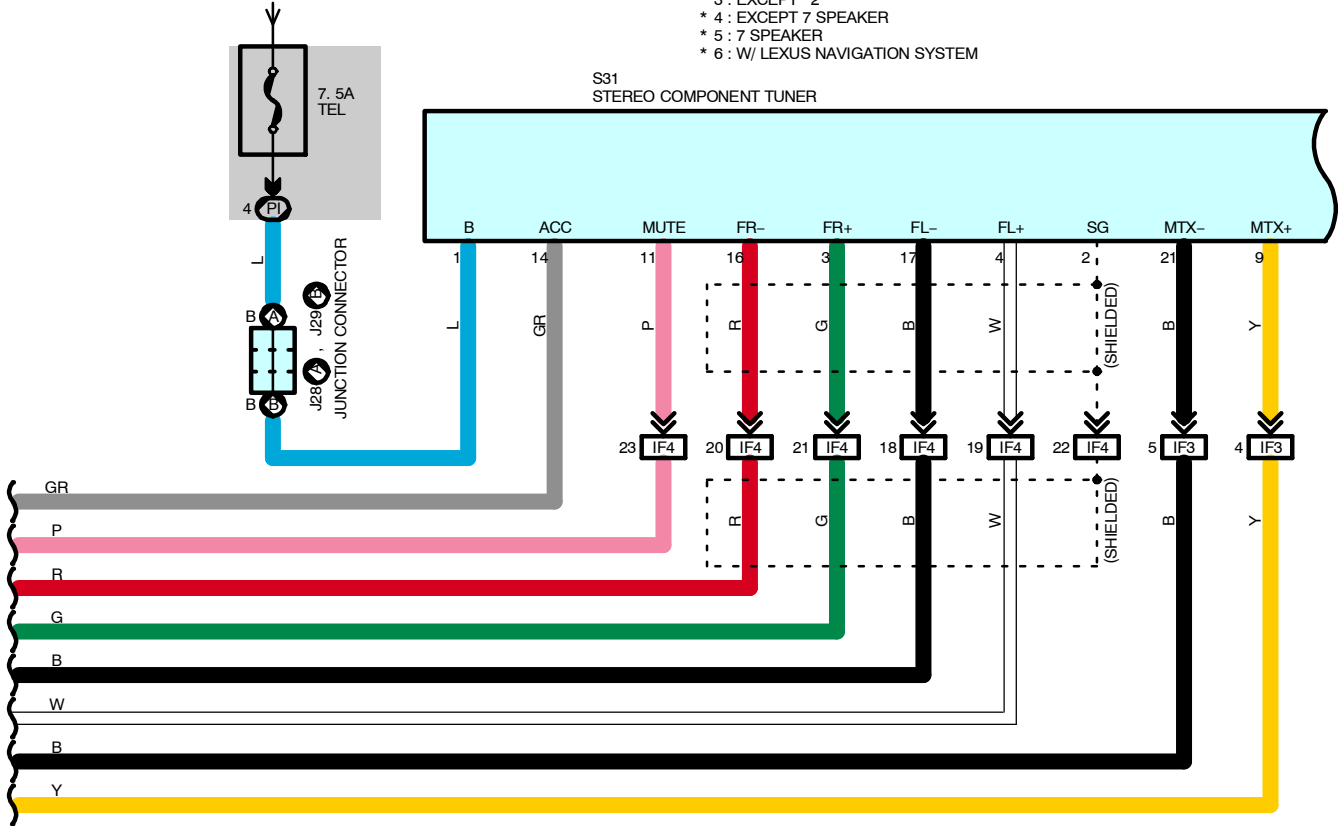

S28 A, S29 B, S30 C  
STEREO COMPONENT AMPLIFIER

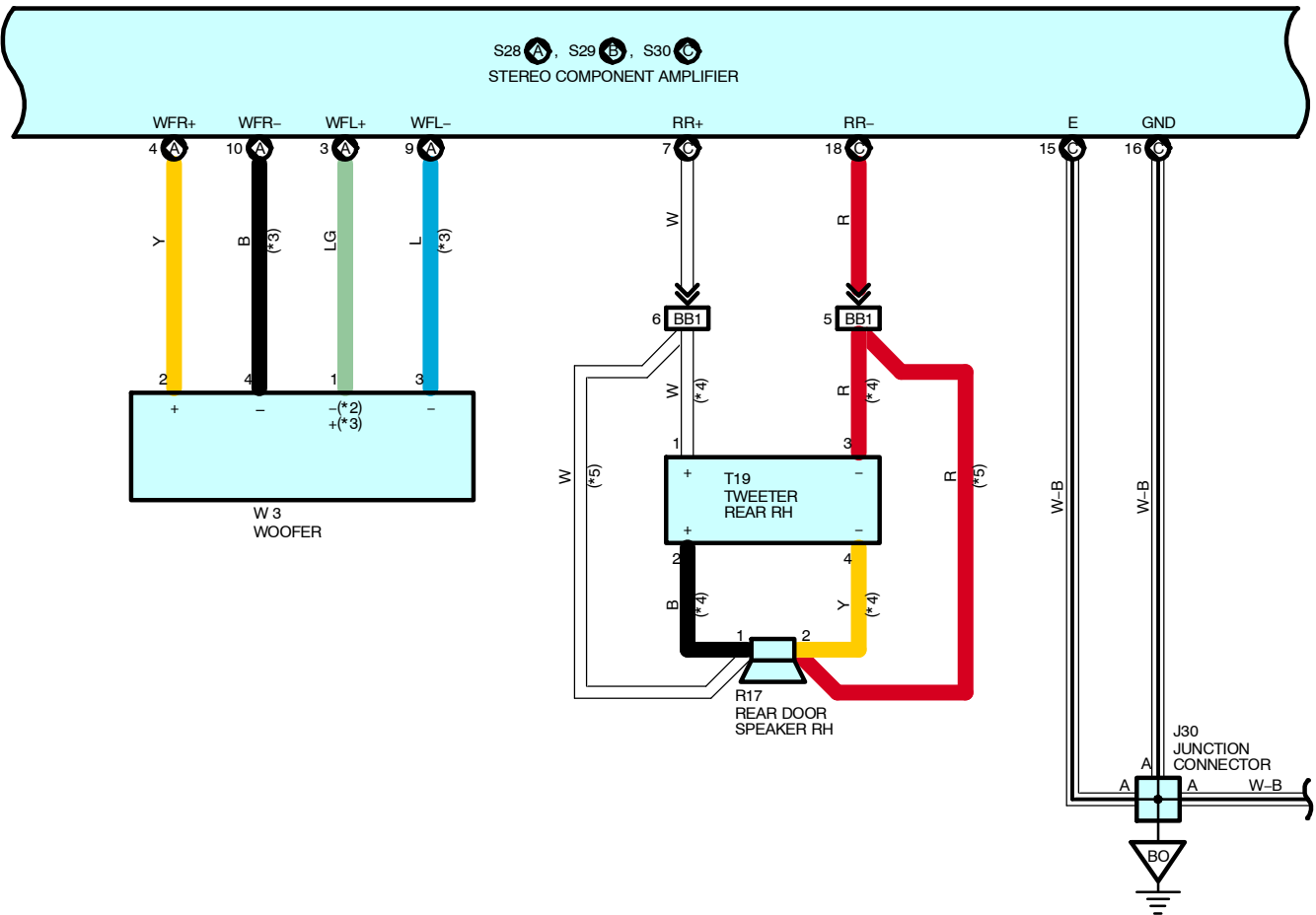

# Audio System

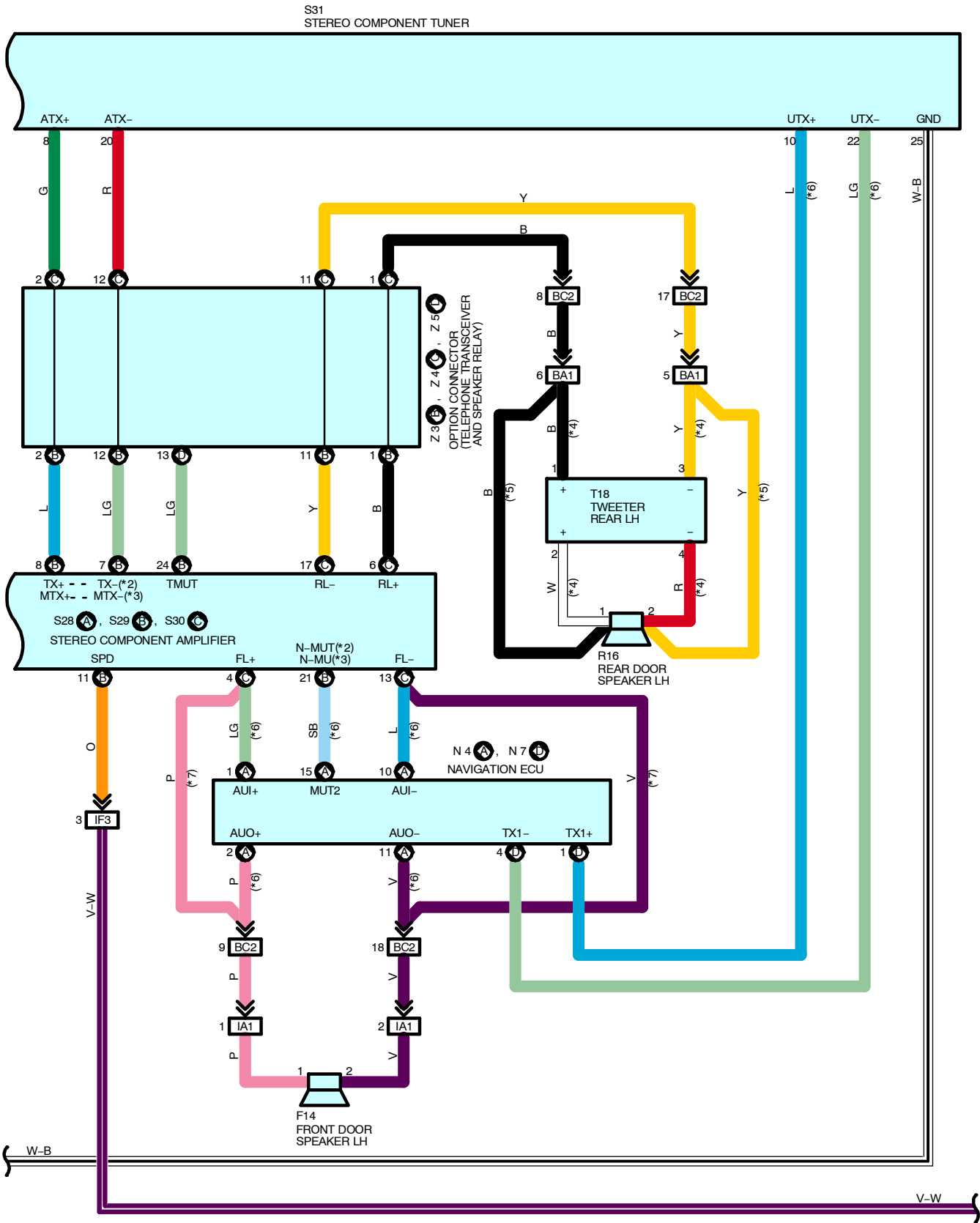

FROM POWER SOURCE SYSTEM (SEE PAGE 72)

- \* 2 : MARK LEVINSON
- \* 3 : EXCEPT \*2
- \* 4 : EXCEPT 7 SPEAKER
- \* 5 : 7 SPEAKER
- \* 6 : W/ LEXUS NAVIGATION SYSTEM
- \* 7 : W/O LEXUS NAVIGATION SYSTEM

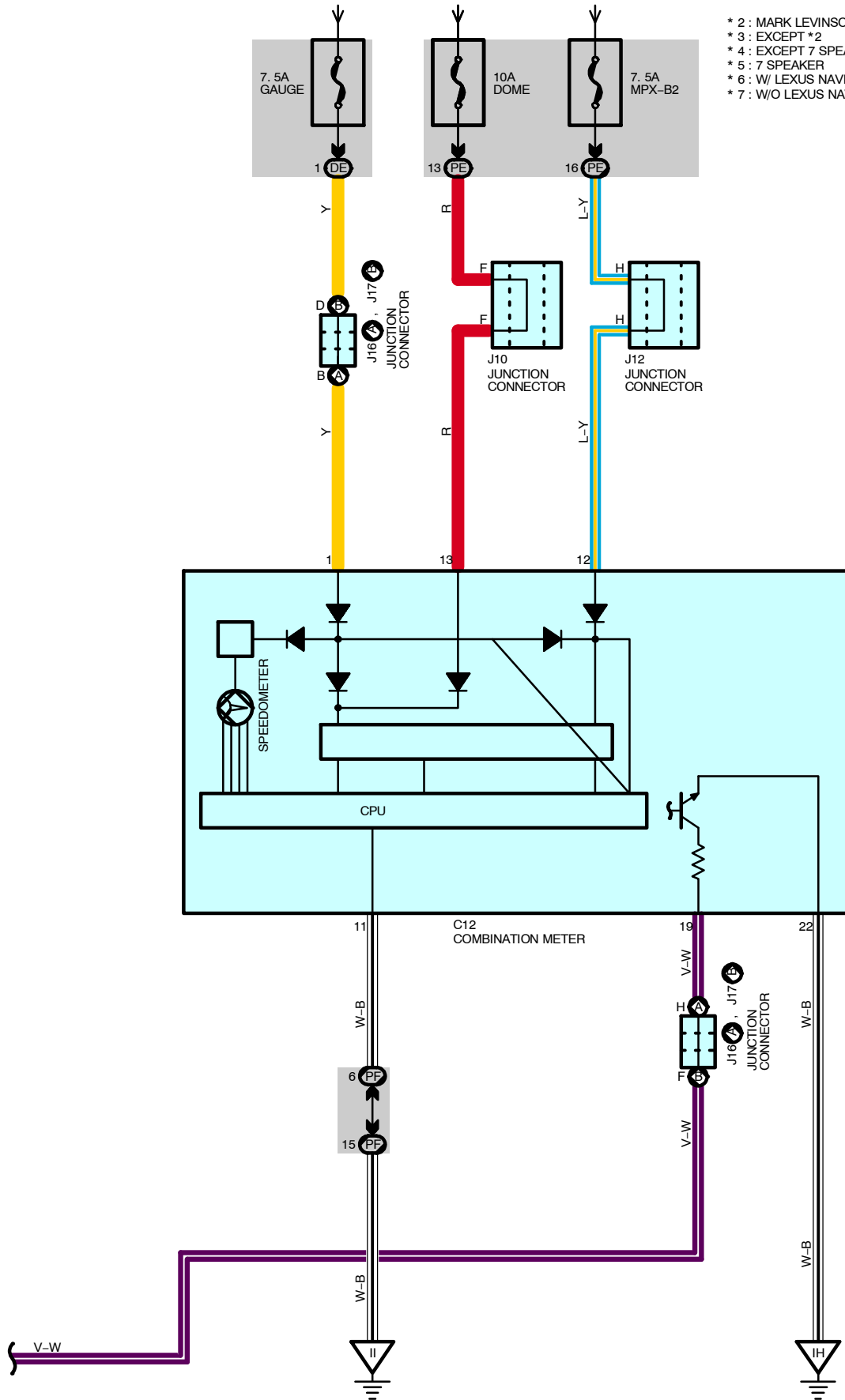

# Audio System

## SERVICE HINTS

### R2 (A) RADIO AND PLAYER

(A)11-GROUND : Approx. **12** volts with ignition SW at **ON** or **ACC** position

(A) 1-GROUND : Always approx. **12** volts

(A)20-GROUND : Always continuity

### S29 (B), S30 (C) STEREO COMPONENT AMPLIFIER

(B) 12-GROUND : Approx. **12** volts with ignition SW at **ON** or **ACC** position

(C) 1, (C) 10-GROUND : Always approx. **12** volts

(C)15, (C) 16-GROUND : Always continuity

### S31 STEREO COMPONENT TUNER

1-GROUND : Always approx. **12** volts

14-GROUND : Approx. **12** volts with ignition SW at **ON** or **ACC** position

25-GROUND : Always continuity

## ○ : PARTS LOCATION

Code	See Page	Code	See Page	Code	See Page		
A35	55	J28	A	51	S30	C	53
C12	46	J29	B	51	S31		53
F14	50	J30		51	T11		49
F15	50	M4		48	T12		49
G3	47	N4	A	52	T18		53
J10	47	N7	D	52	T19		53
J12	47	R2	A	49	W3		53
J14	A	R3	B	49	Z3	B	53
J15	B	R16		52	Z4	C	53
J16	A	R17		52	Z5	D	53
J17	B	S28	A	53			
J23	51	S29	B	53			

## ○ : JUNCTION BLOCK AND WIRE HARNESS CONNECTOR

Code	See Page	Junction Block and Wire Harness (Connector Location)
DE	29	Instrument Panel Wire and Driver Side J/B (Left Kick Panel)
LC	40	Floor No.2 Wire and Luggage Room J/B (Luggage Room Left)
LE		
LF		
PE	36	Instrument Panel Wire and Passenger Side J/B (Right Kick Panel)
PF		
PI	37	Floor Wire and Passenger Side J/B (Right Kick Panel)

## □ : CONNECTOR JOINING WIRE HARNESS AND WIRE HARNESS

Code	See Page	Joining Wire Harness and Wire Harness (Connector Location)
IA1	58	Front Door LH Wire and Floor No.2 Wire (Left Kick Panel)
IF3	60	Instrument Panel Wire and Floor Wire (Right Side of Shift Lever)
IF4		
IG3	60	Instrument Panel Wire and Floor Wire (Cowl Side Panel RH)
IJ1	60	Front Door RH Wire and Floor Wire (Right Kick Panel)
BA1	62	Rear Door No.2 Wire and Floor No.2 Wire (Left Center Pillar)
BB1	62	Rear Door No.1 Wire and Floor Wire (Right Center Pillar)
BC2	62	Floor No.2 Wire and Floor Wire (Rear Floor Partition Panel LH)
BE3	62	Floor No.2 Wire and Floor Wire (Lower Back Panel RH)
BH2	68	Rear Seat LH Wire and Floor No.2 Wire (Under the Rear Passenger's LH Seat)
BH3		
BT2	68	Switch Wire and Rear Seat LH Wire (Back the Rear Seat LH)

**: GROUND POINTS**

Code	See Page	Ground Points Location
IH	58	Right Side of Shift Lever
II		
IJ	58	Instrument Panel Brace RH
BM	62	Quarter Panel LH
BO	62	Quarter Panel RH
BP	68	Rear Passenger LH Seat Back

**: SPLICE POINTS**

Code	See Page	Wire Harness with Splice Points	Code	See Page	Wire Harness with Splice Points
B8	68	Rear Seat LH Wire	B12	64	Floor Wire