

Multiplex Communication System (J/B ECU)

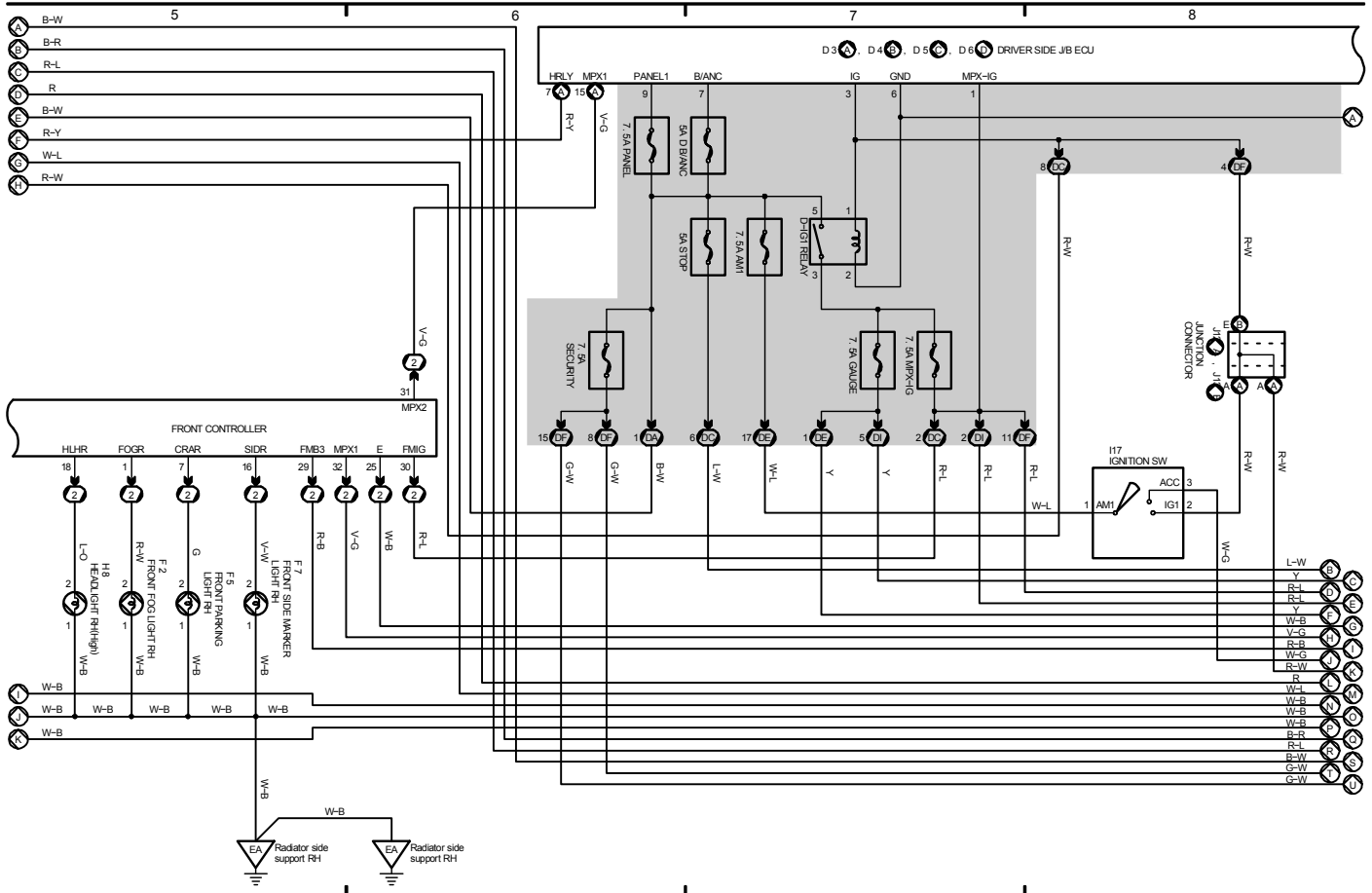

Multiplex Communication System (J/B ECU)

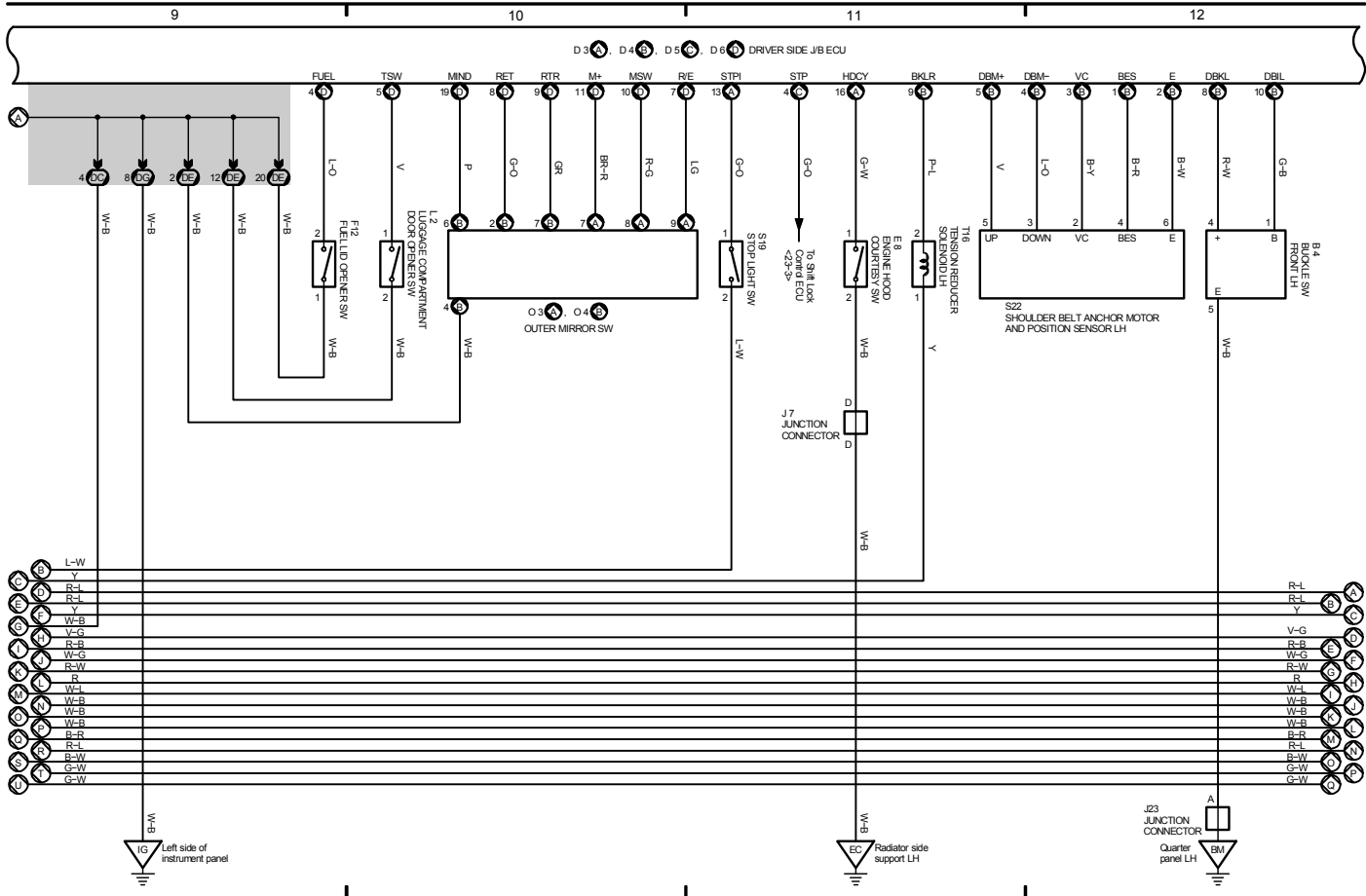

Multiplex Communication System (J/B ECU)

* 1 : w/ LEXUS Park Assist(Clearance Sonar)
 * 2 : w/ Electronic Modulated Air Suspension

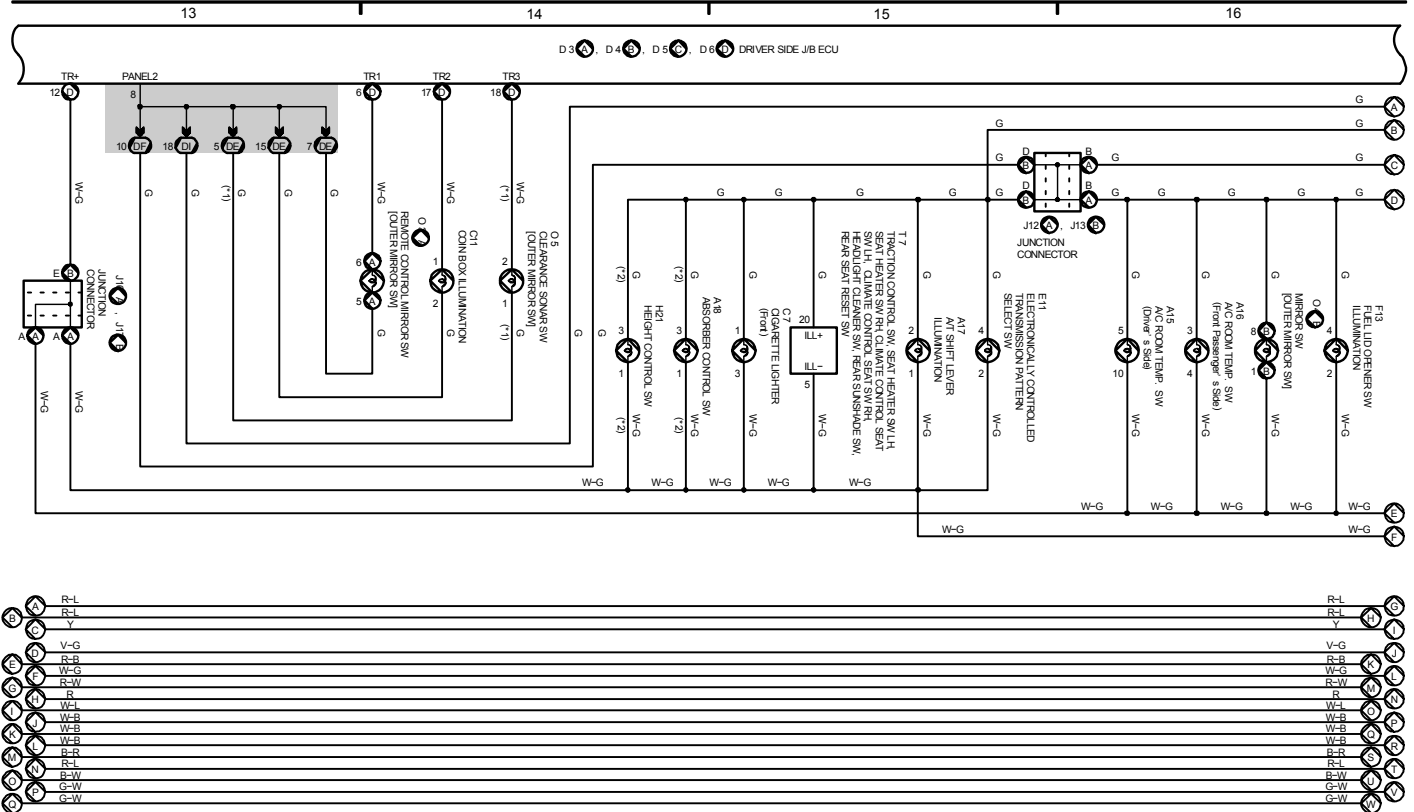

Multiplex Communication System (J/B ECU)

- * 3 : w/ Rear Power Seat
- * 4 : w/ LEXUS Navigation System
- * 5 : w/o LEXUS Navigation System
- * 6 : w/ Garage Door Opener
- * 7 : w/o Rear Power Seat

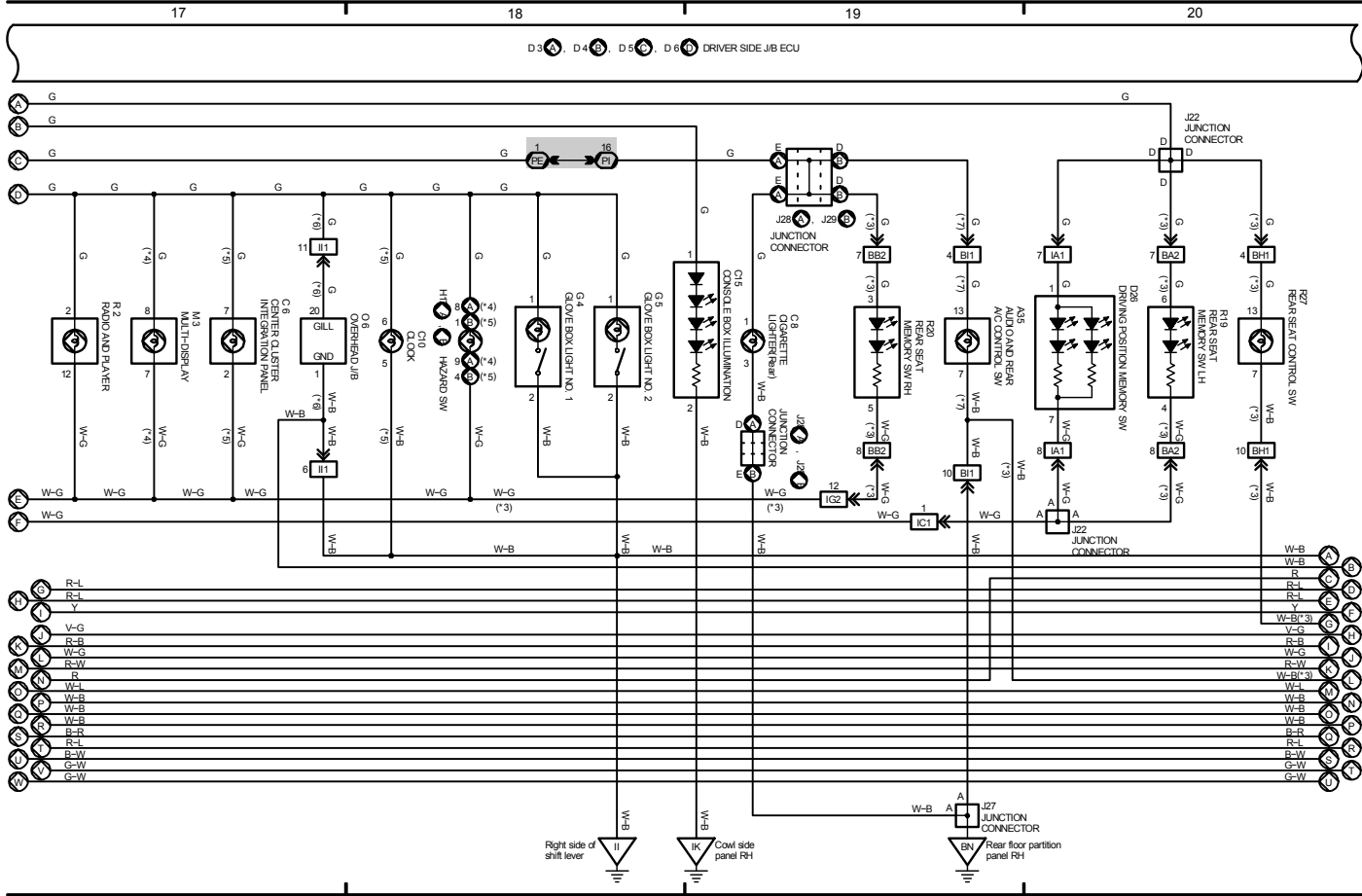

Multiplex Communication System (J/B ECU)

- * 3 : w/ Rear Power Seat
- * 4 : w/ LEXUS Navigation System
- * 5 : w/o LEXUS Navigation System
- * 8 : w/ Rear Cooler

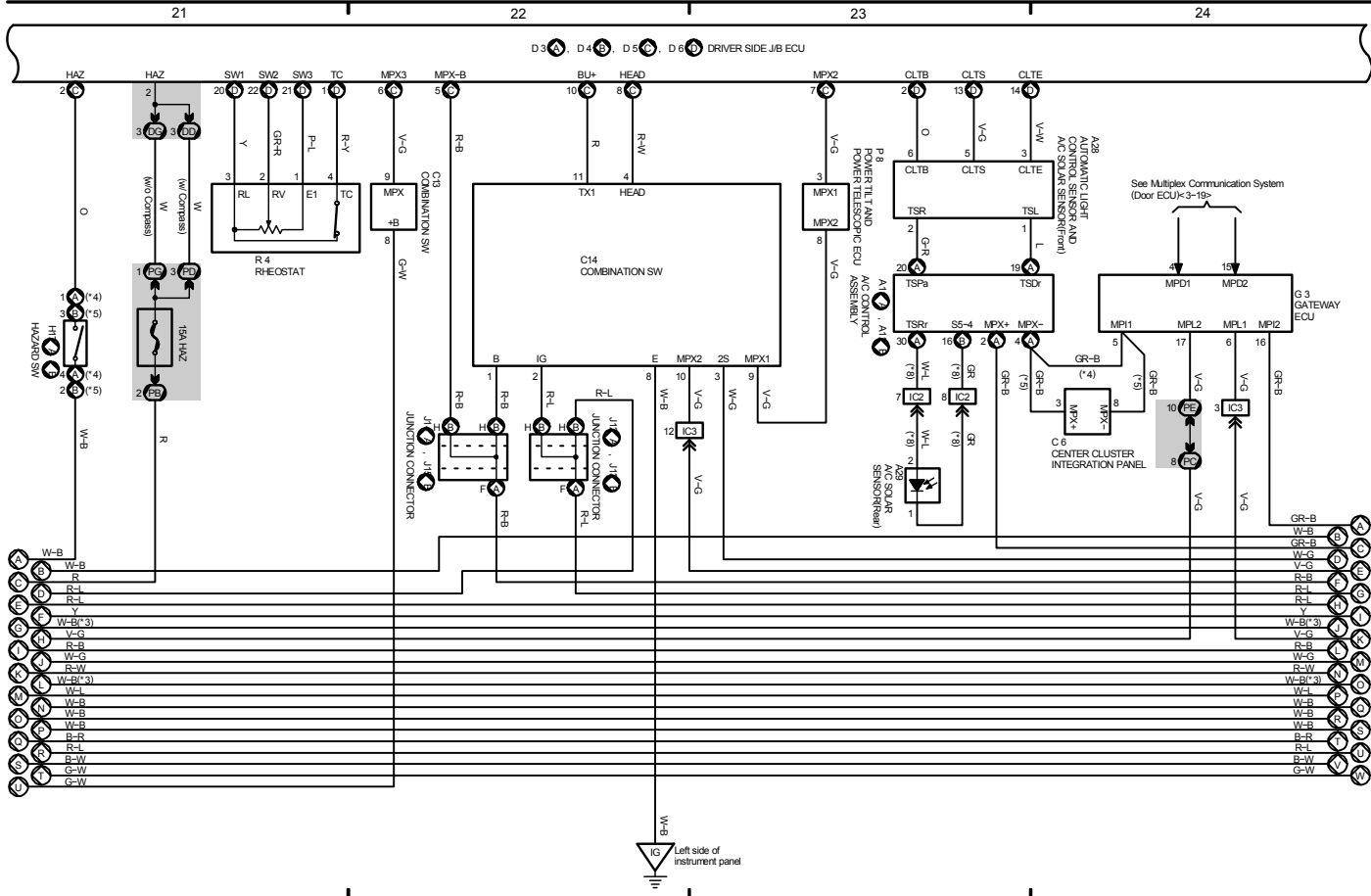

Multiplex Communication System (J/B ECU)

* 3 : w/ Rear Power Seat
 * 9 : w/ Headlight Cleaner

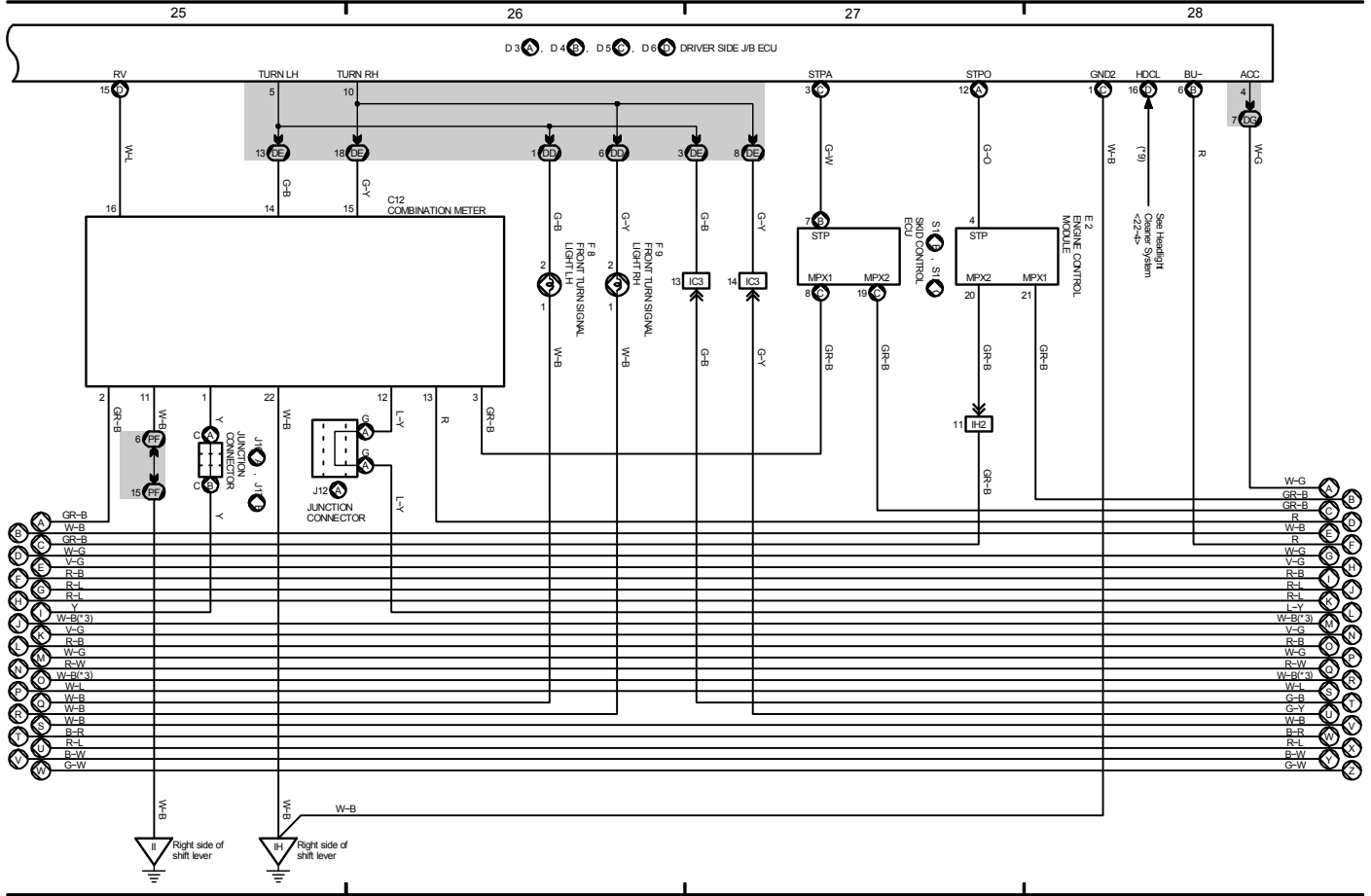

Multiplex Communication System (J/B ECU)

* 3 : w/ Rear Power Seat

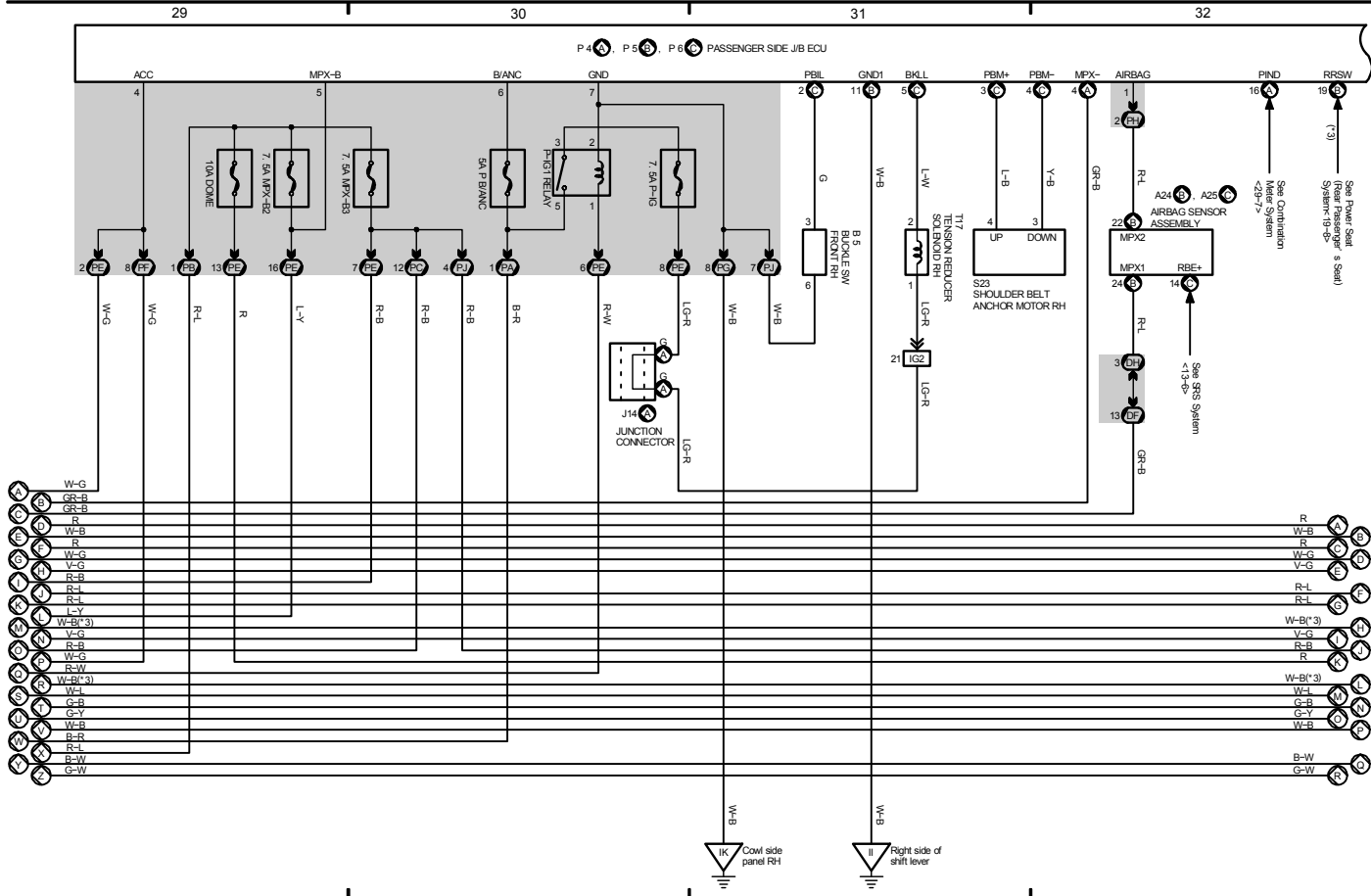

Multiplex Communication System (J/B ECU)

* 3 : w/ Rear Power Seat

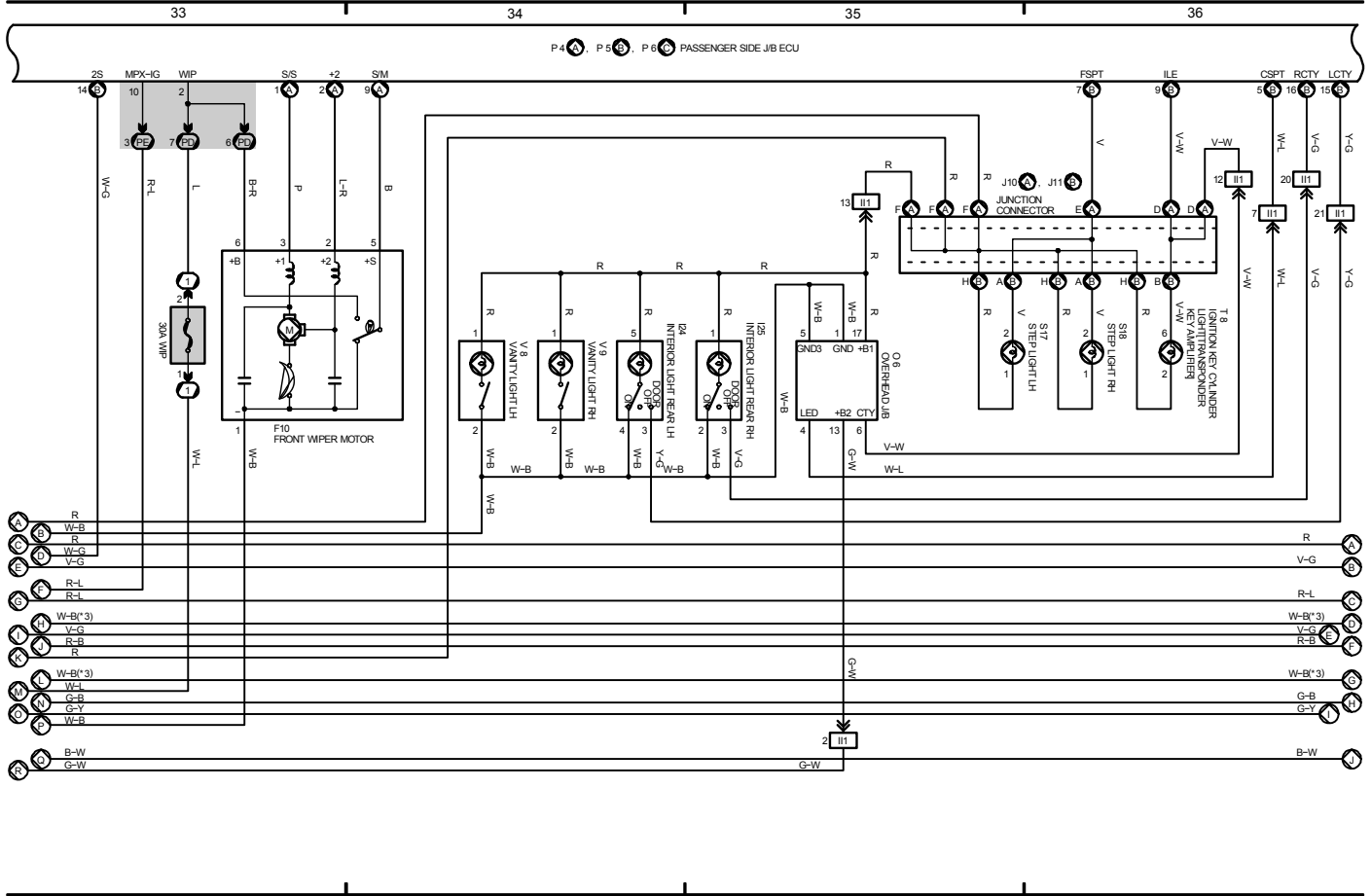

Multiplex Communication System (J/B ECU)

- * 1: w/ LEXUS Park Assist(Clearance Sonar)
- * 3: w/ Rear Power Seat
- * 4: w/ LEXUS Navigation System

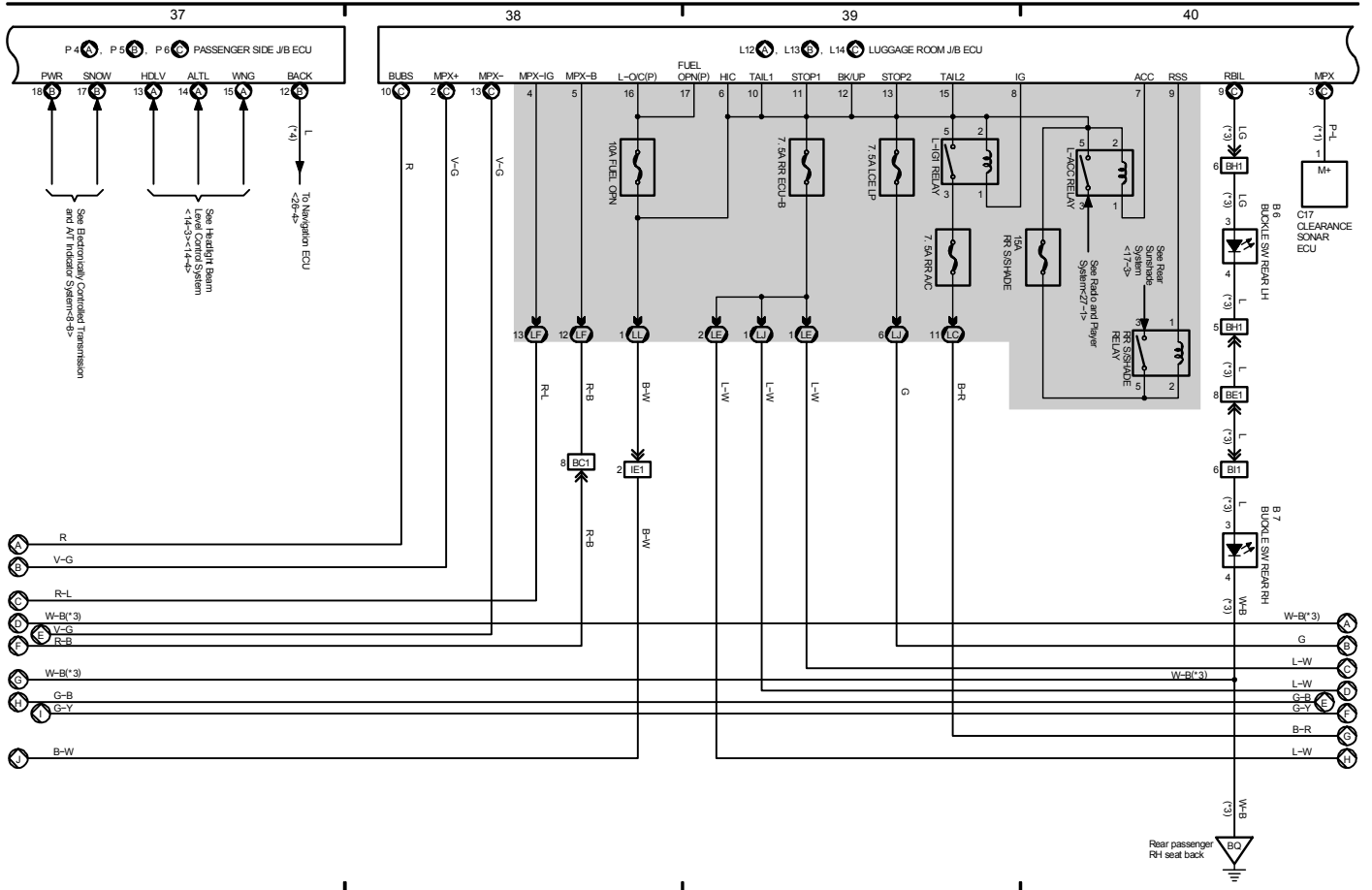

Multiplex Communication System (J/B ECU)

* 3 : w/ Rear Power Seat

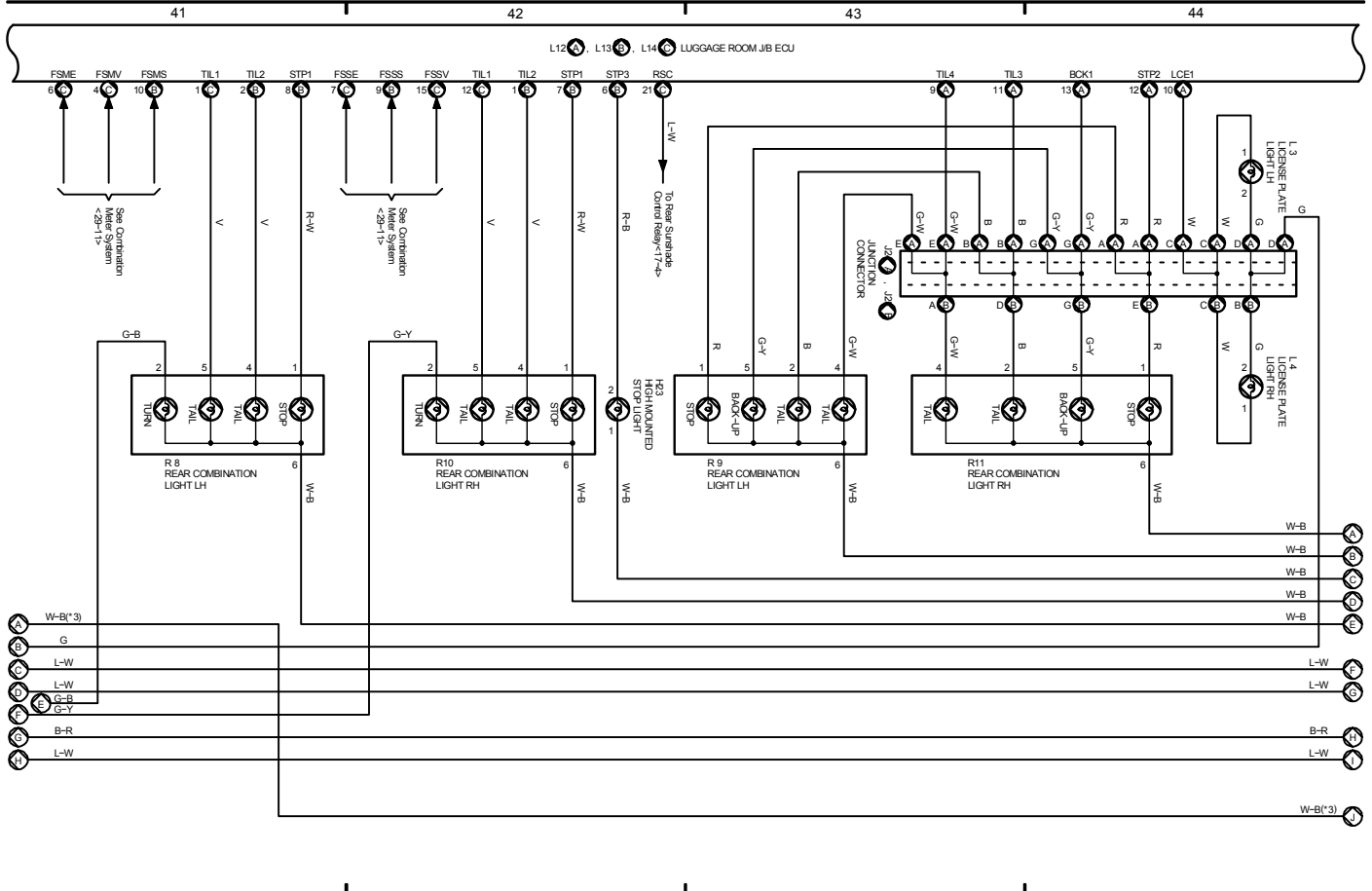

Multiplex Communication System (J/B ECU)

* 3 : w/ Rear Power Seat

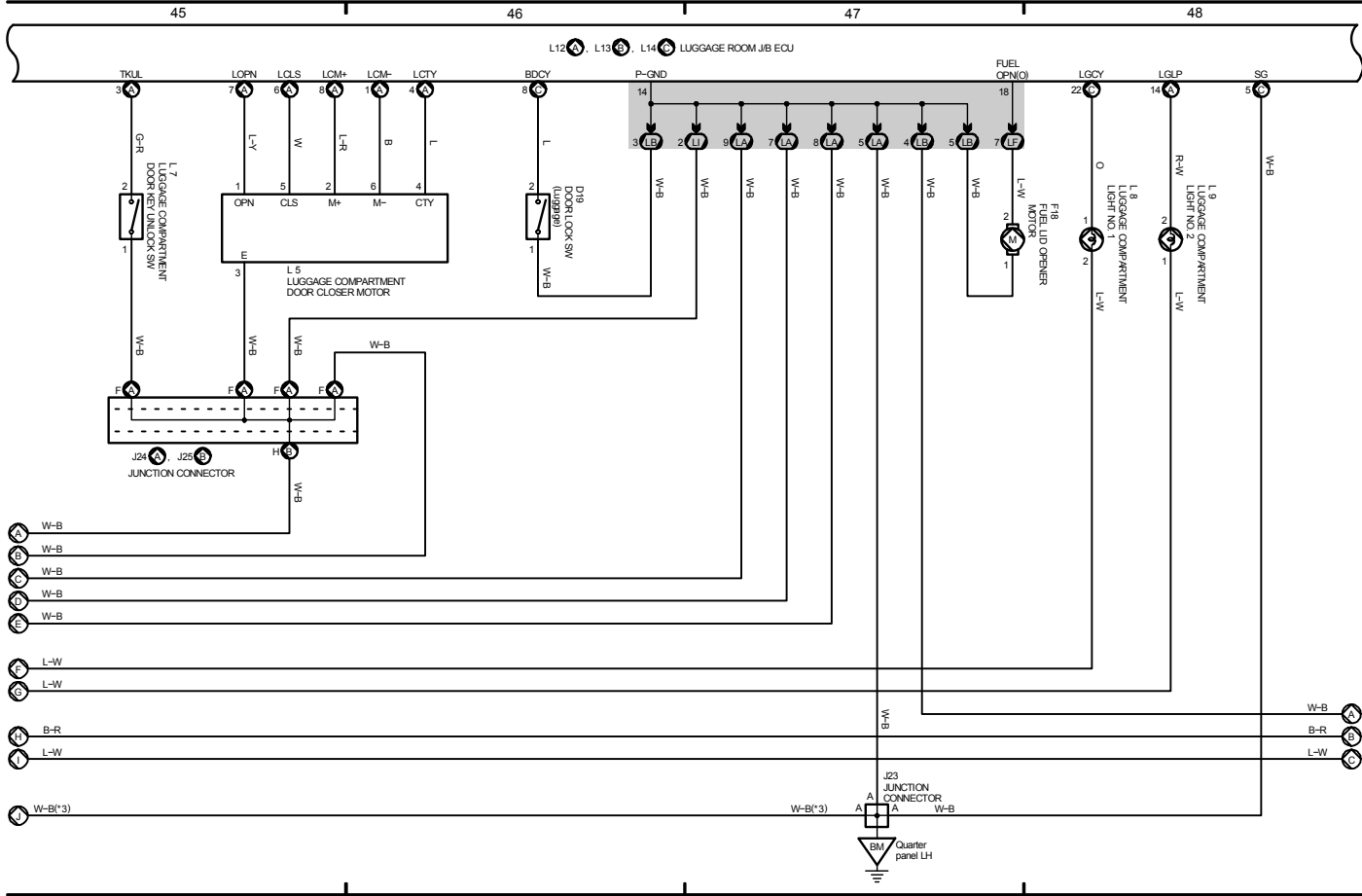

Multiplex Communication System (J/B ECU)

* 8 : w/ Rear Cooler
 * 10 : w/o Rear Cooler

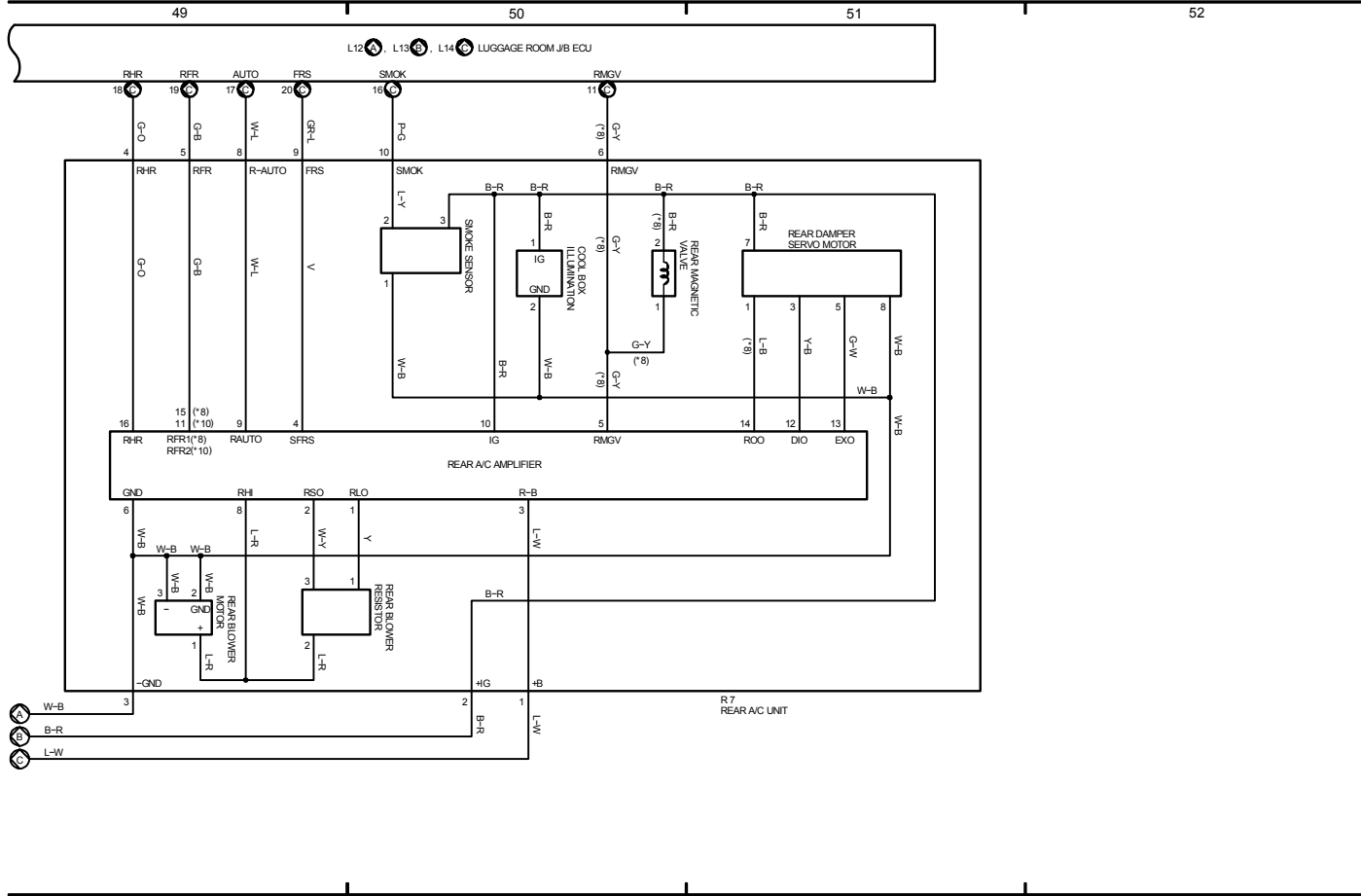

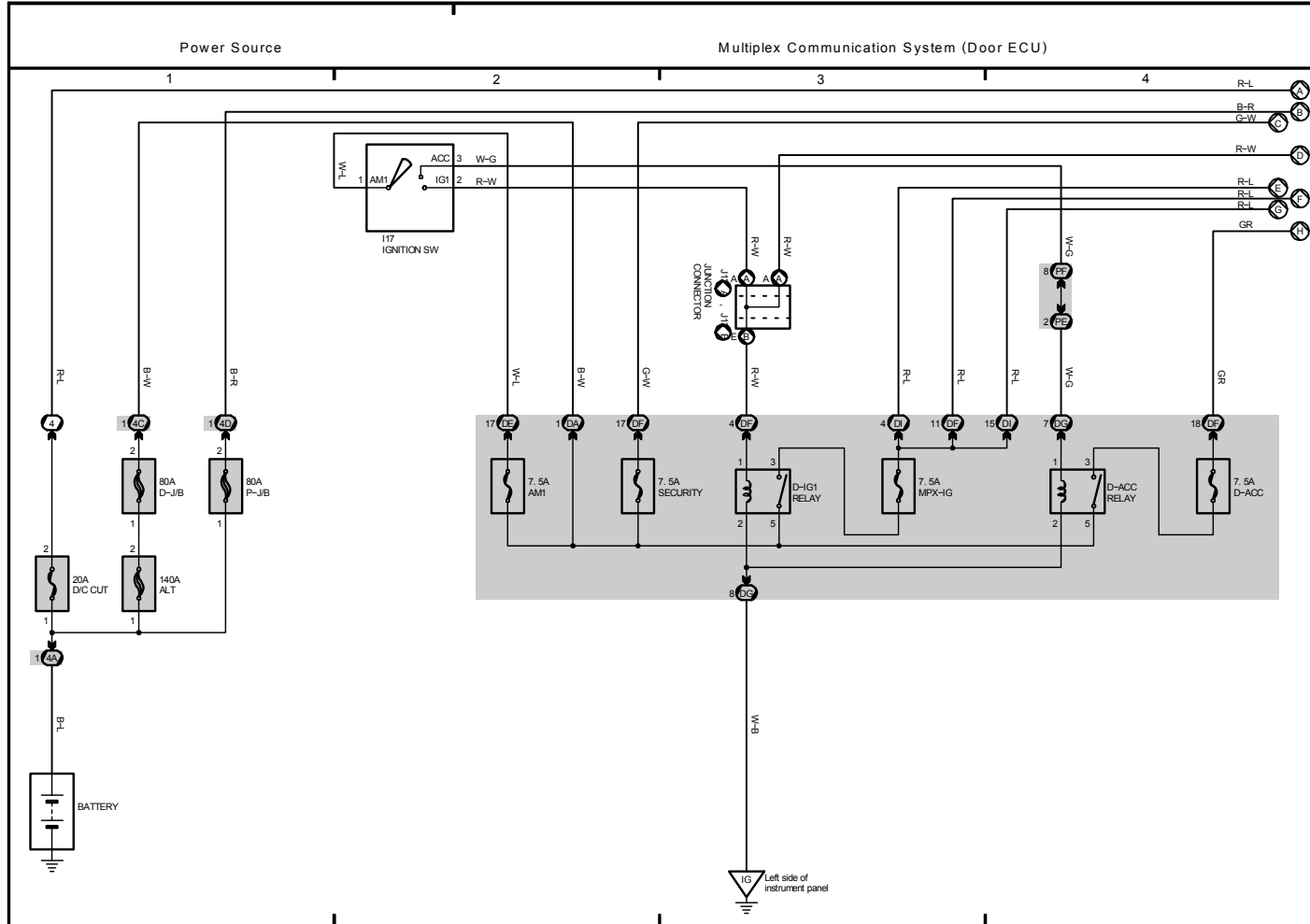

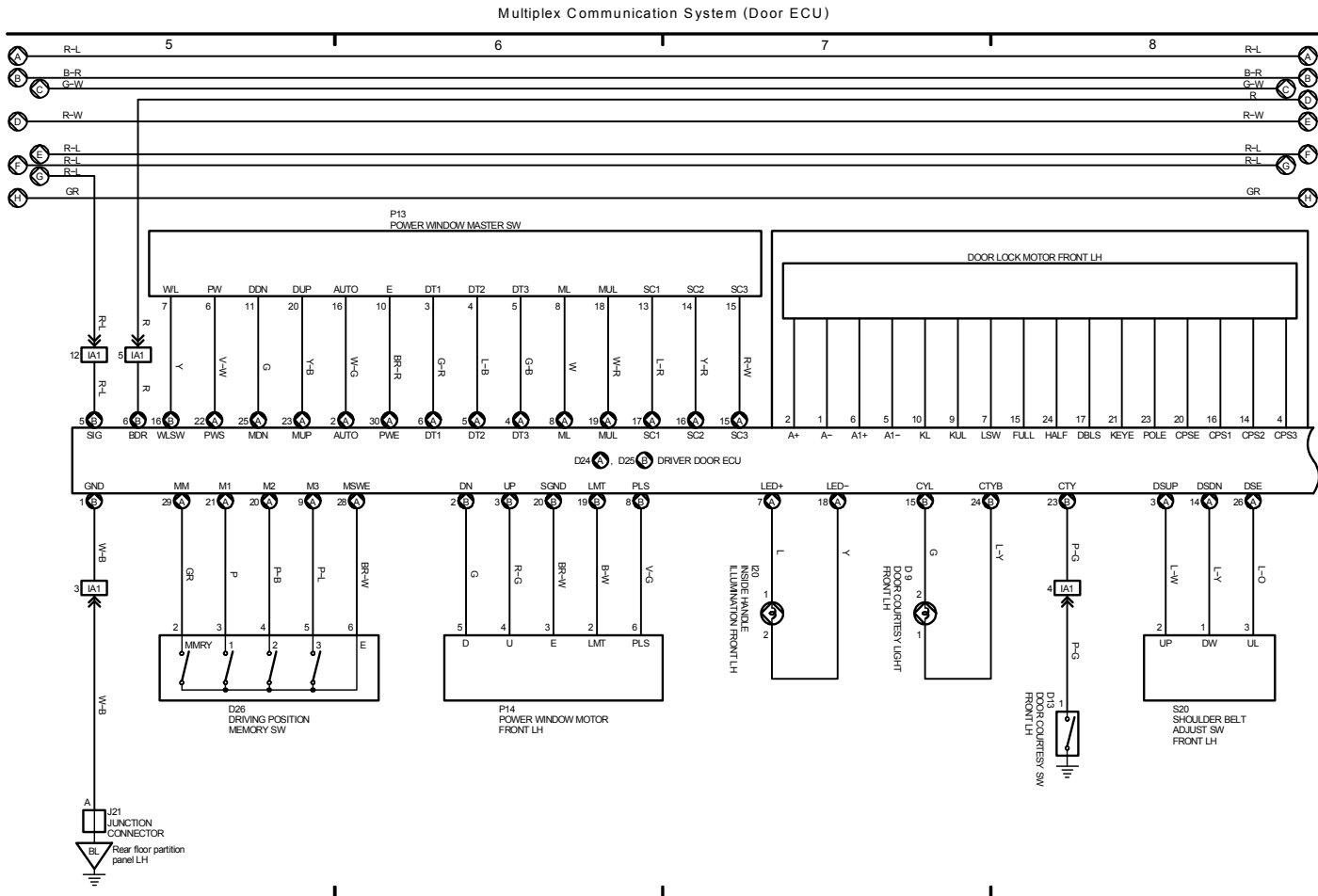

Multiplex Communication System (Door ECU)

* 1 : w/ Rear Power Seat

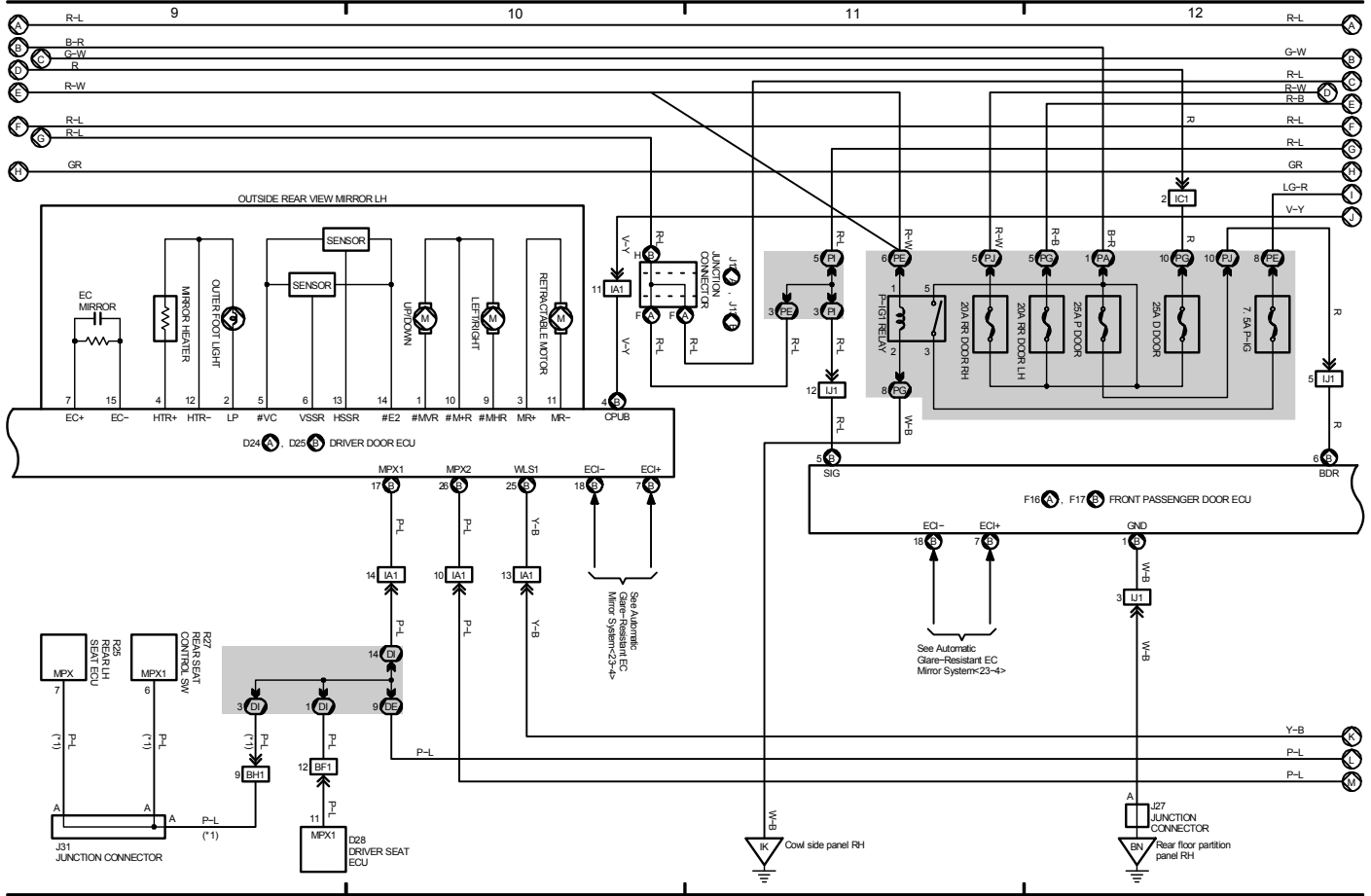

Multiplex Communication System (Door ECU)

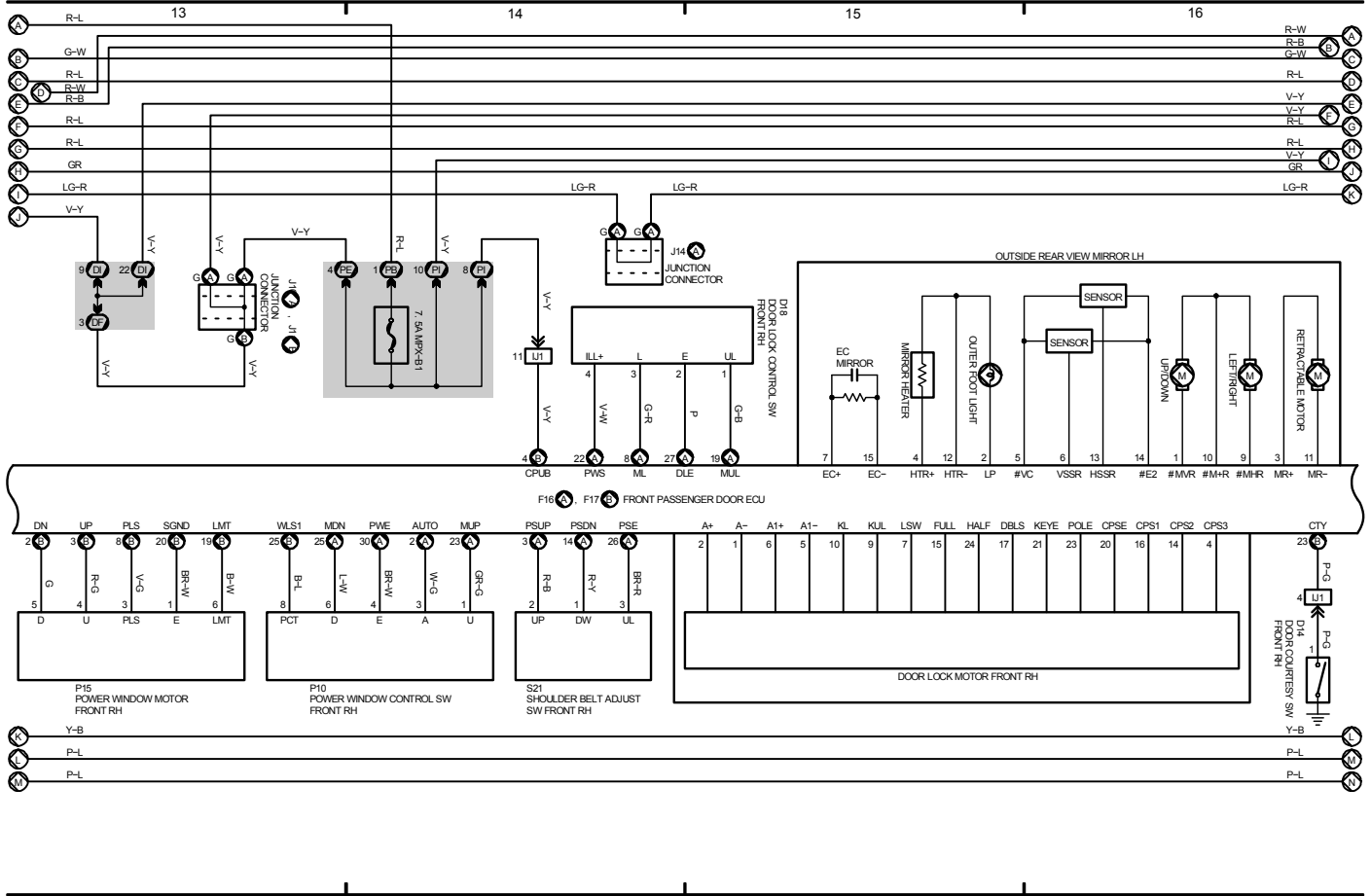

Multiplex Communication System (Door ECU)

* 1 : w/ Rear Power Seat
* 2 : w/ LEXUS Link System(Mayday System)

* 3 : w/ Rain Sensor
* 4 : w/ Moon Roof

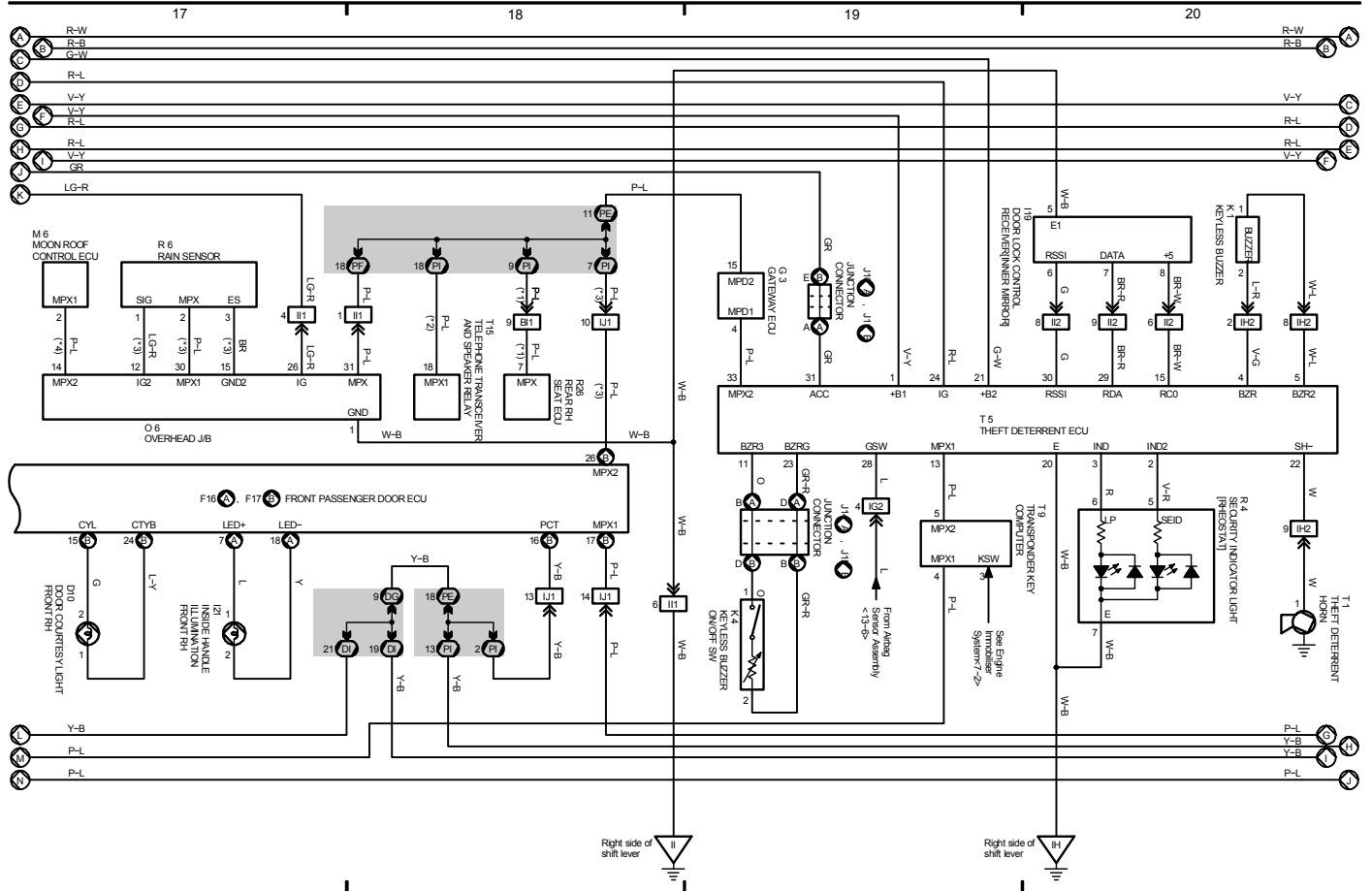

Multiplex Communication System (Door ECU)

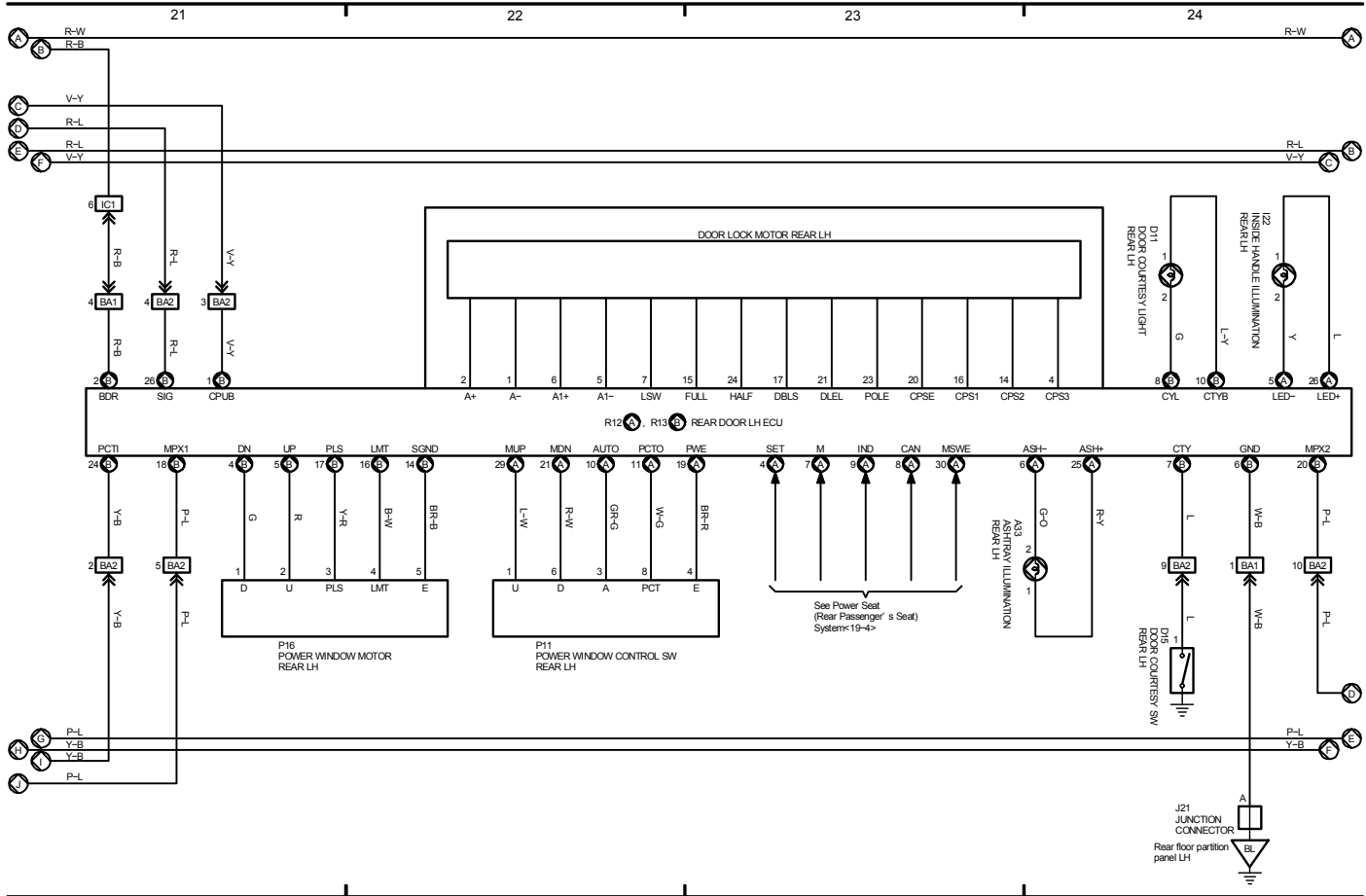

Multiplex Communication System (Door ECU)

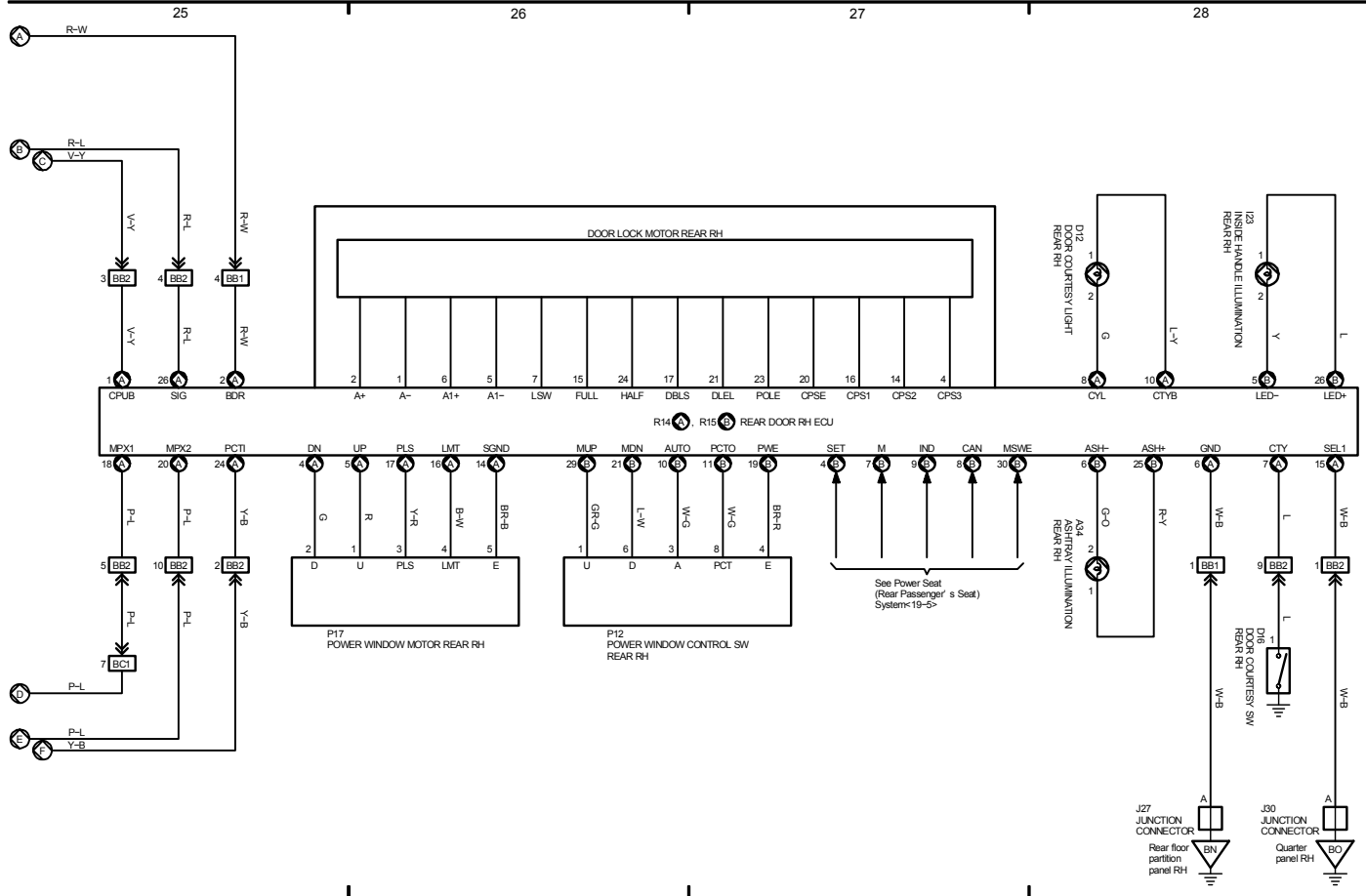

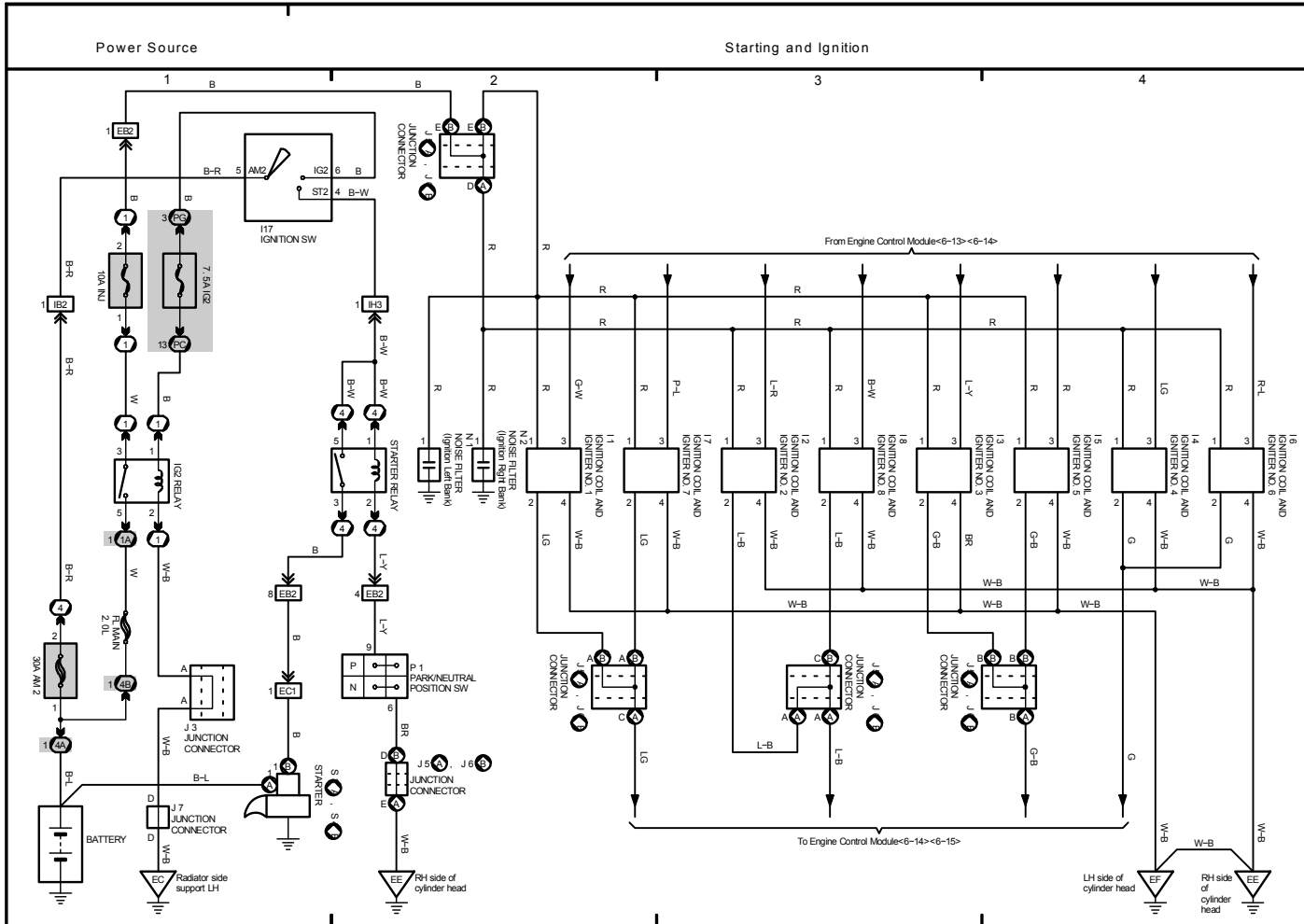

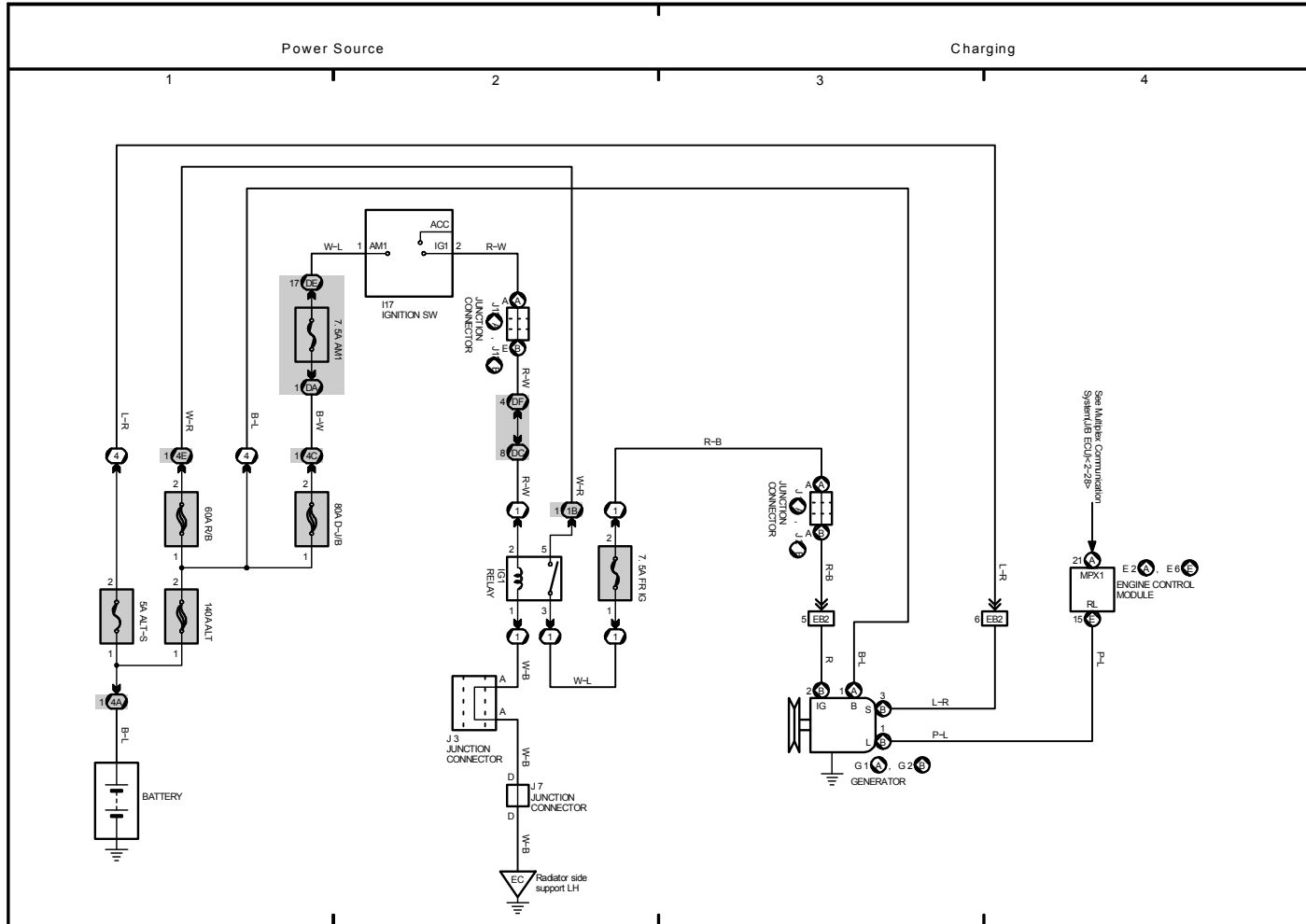

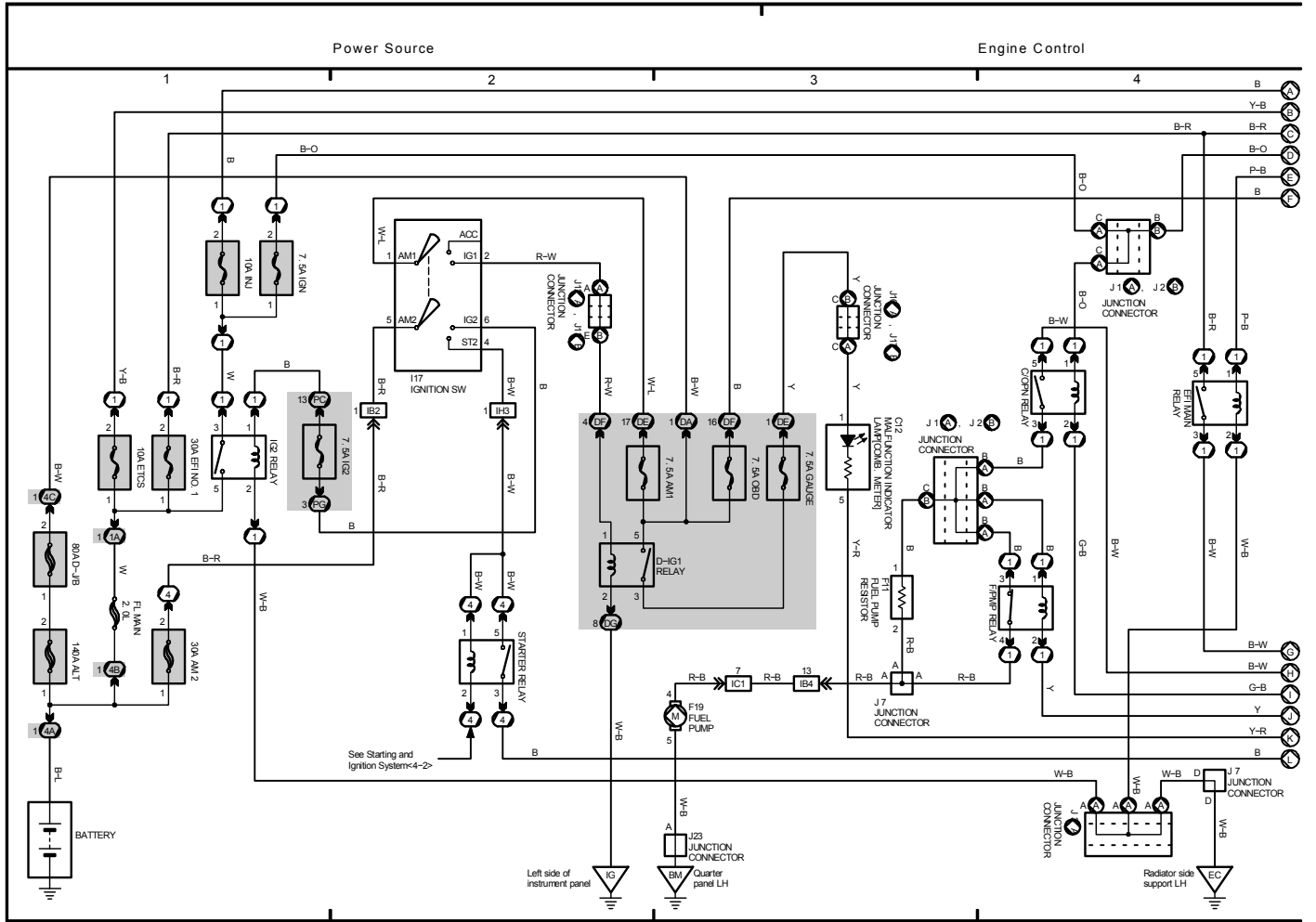

OVERALL ELECTRICAL WIRING DIAGRAM

Engine Control

* 1 : w/ Electronic Modulated Air Suspension
 * 2 : w/ LEXUS Navigation System

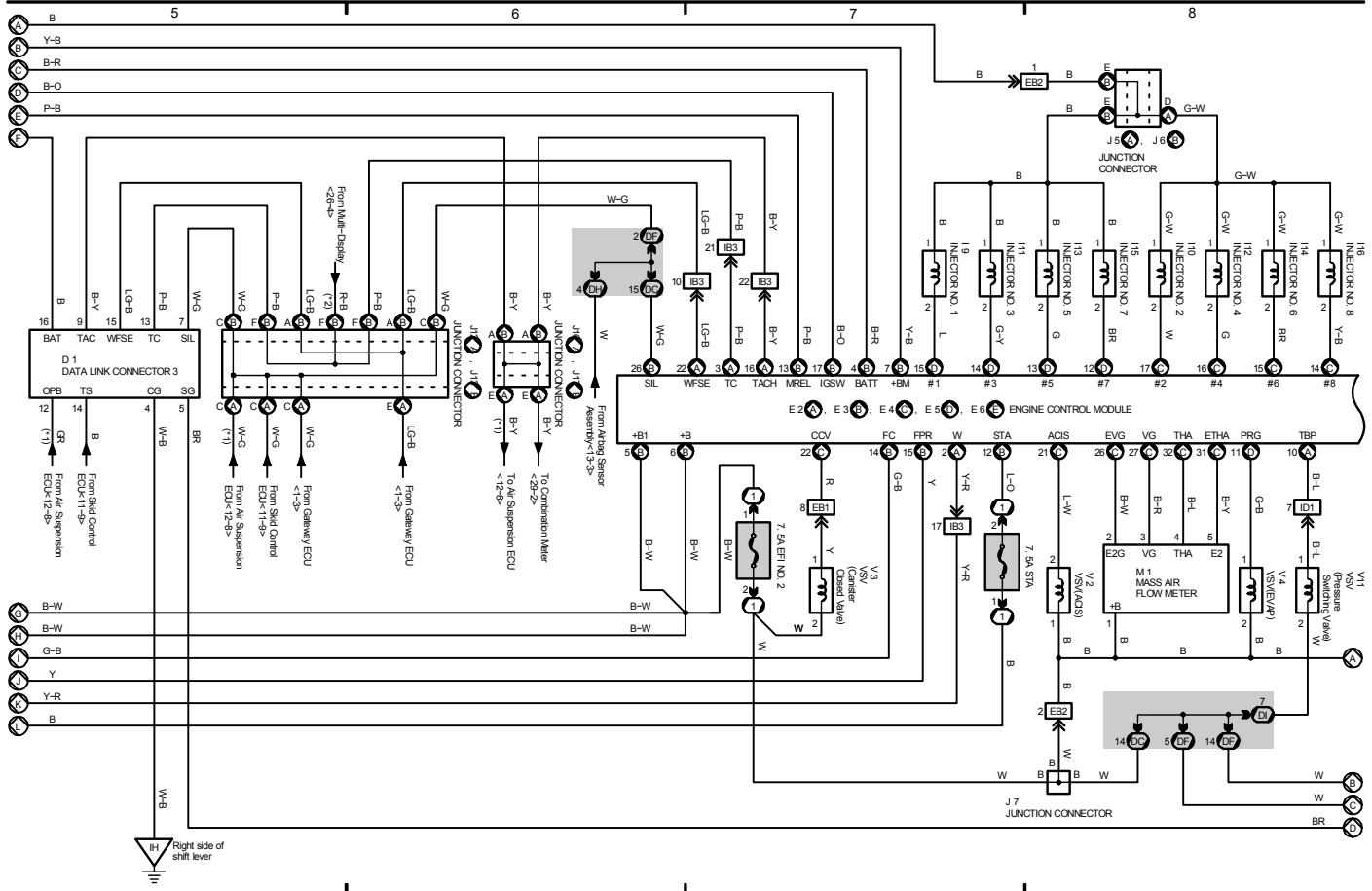

Engine Control

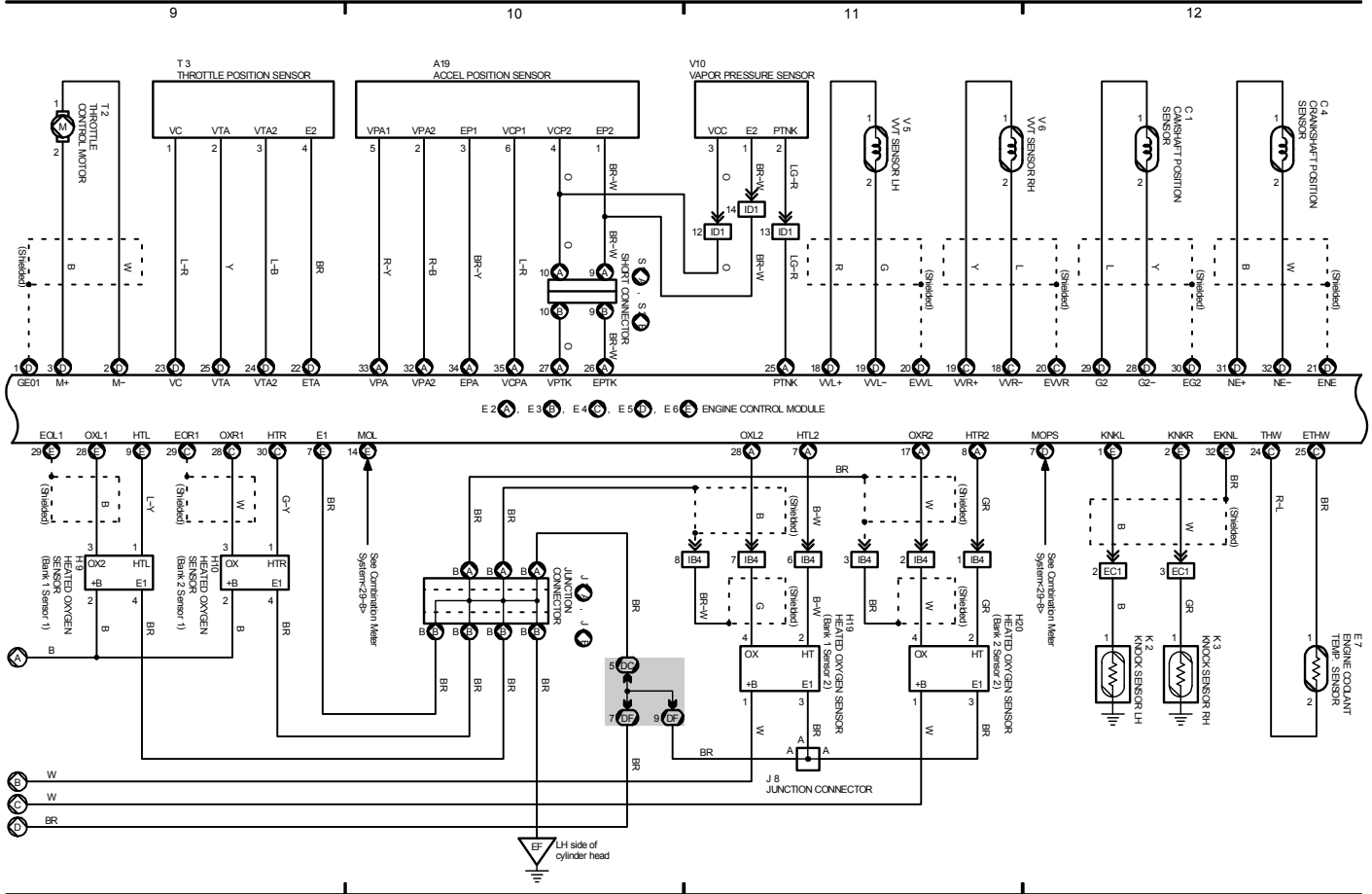

Engine Control

* 1: Electronic Modulated Air Suspension
 * 3: w/ Adaptive Laser Cruise Control

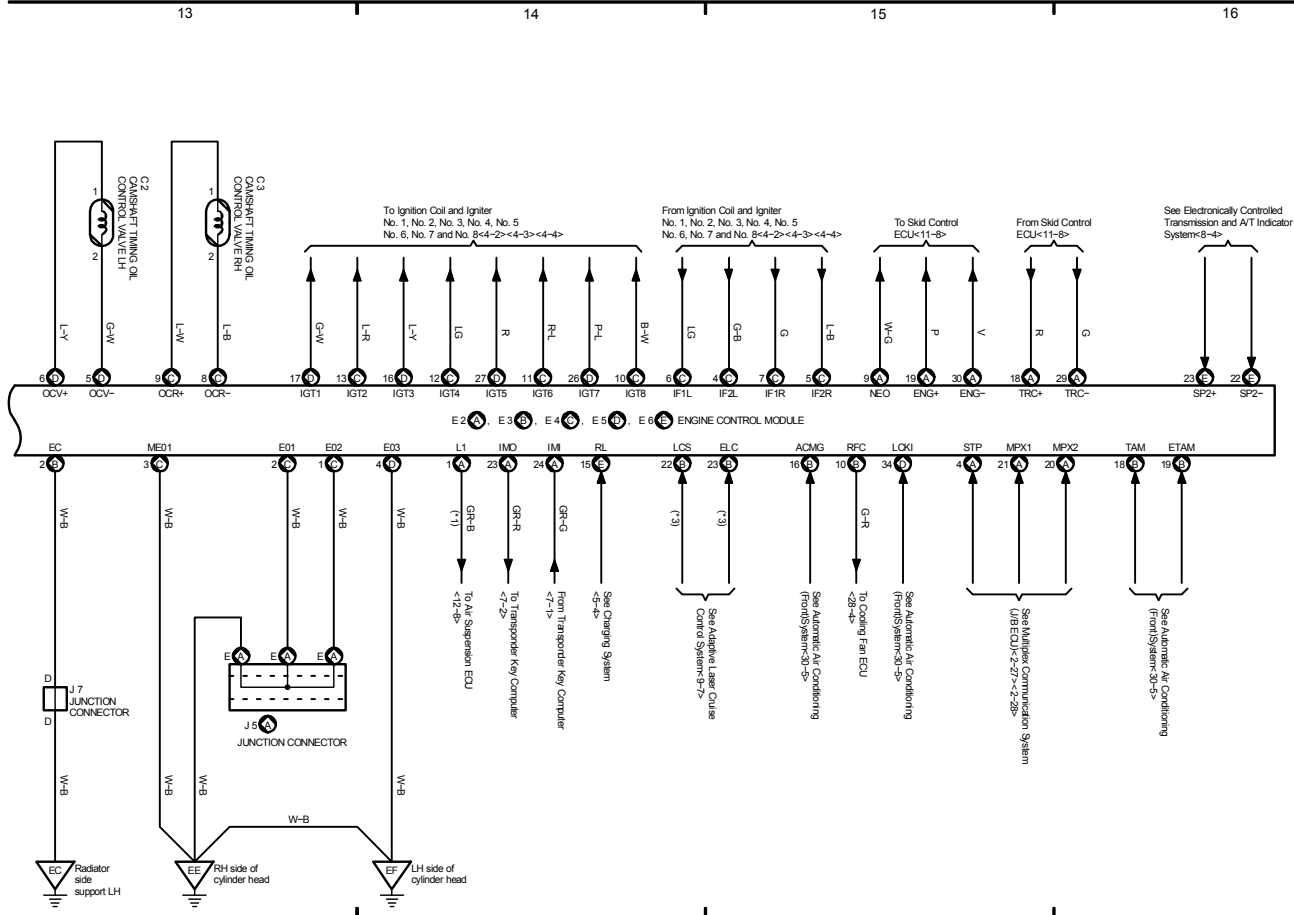

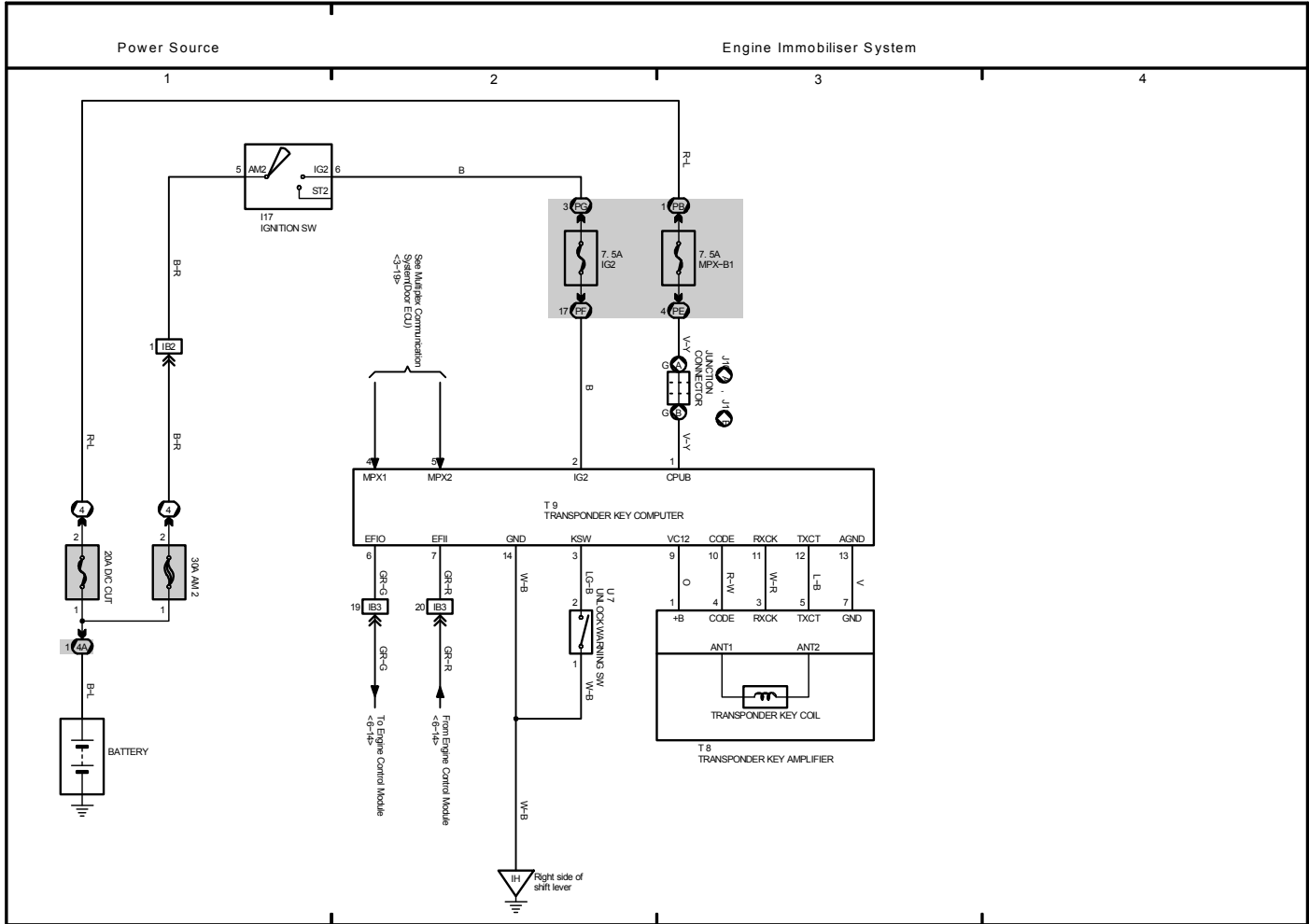

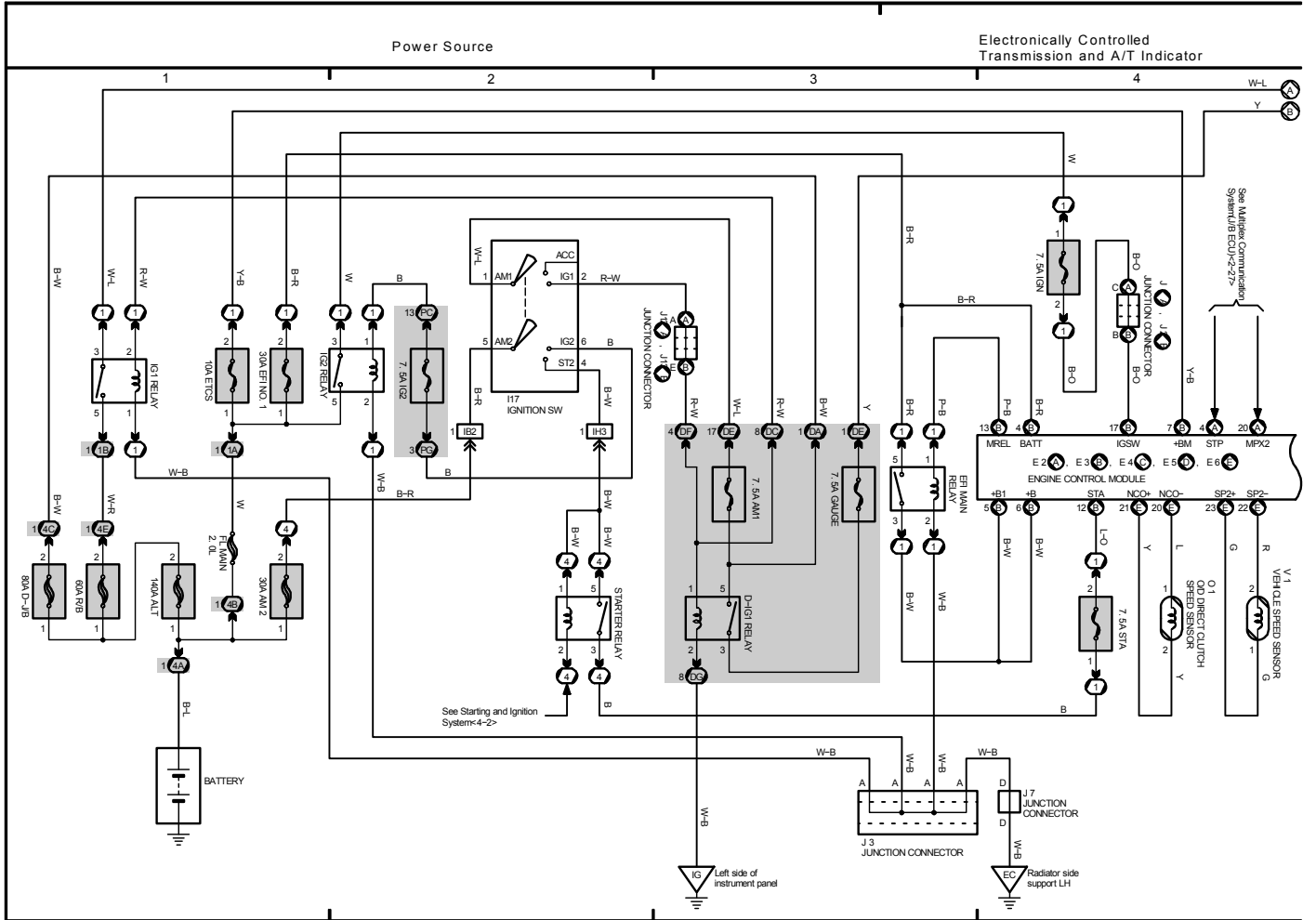

Electrically Controlled Transmission and A/T Indicator

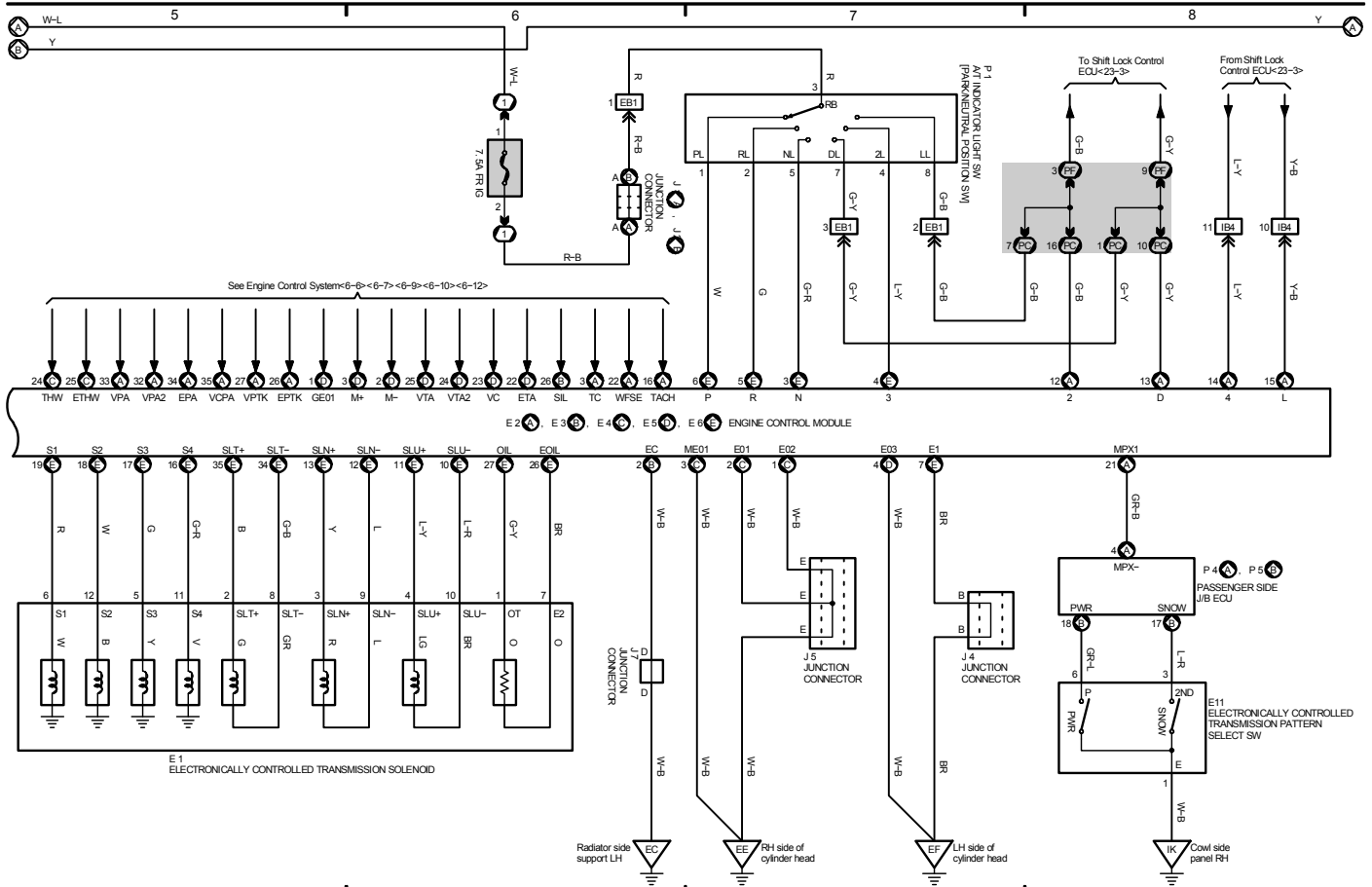

Electronically Controlled Transmission and A/T Indicator

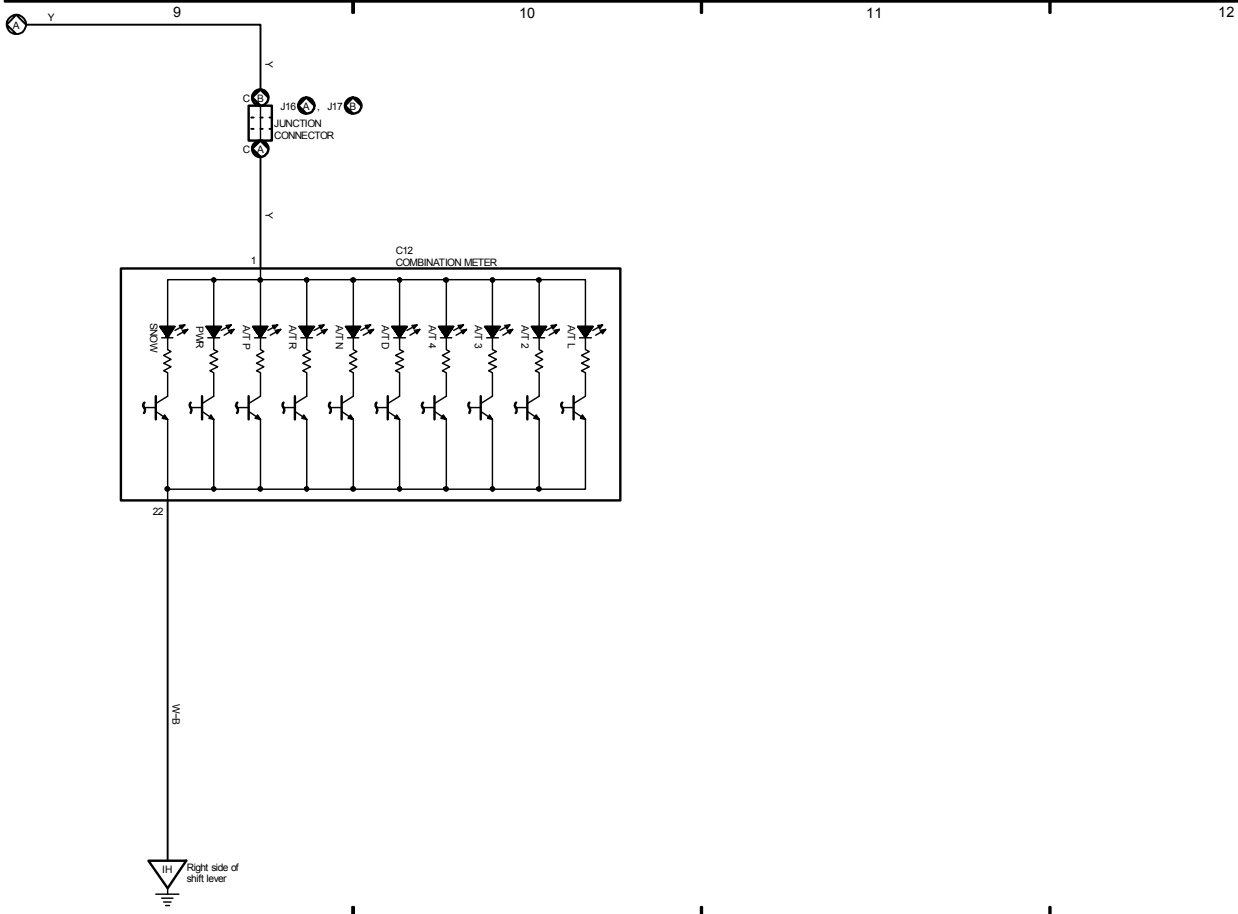

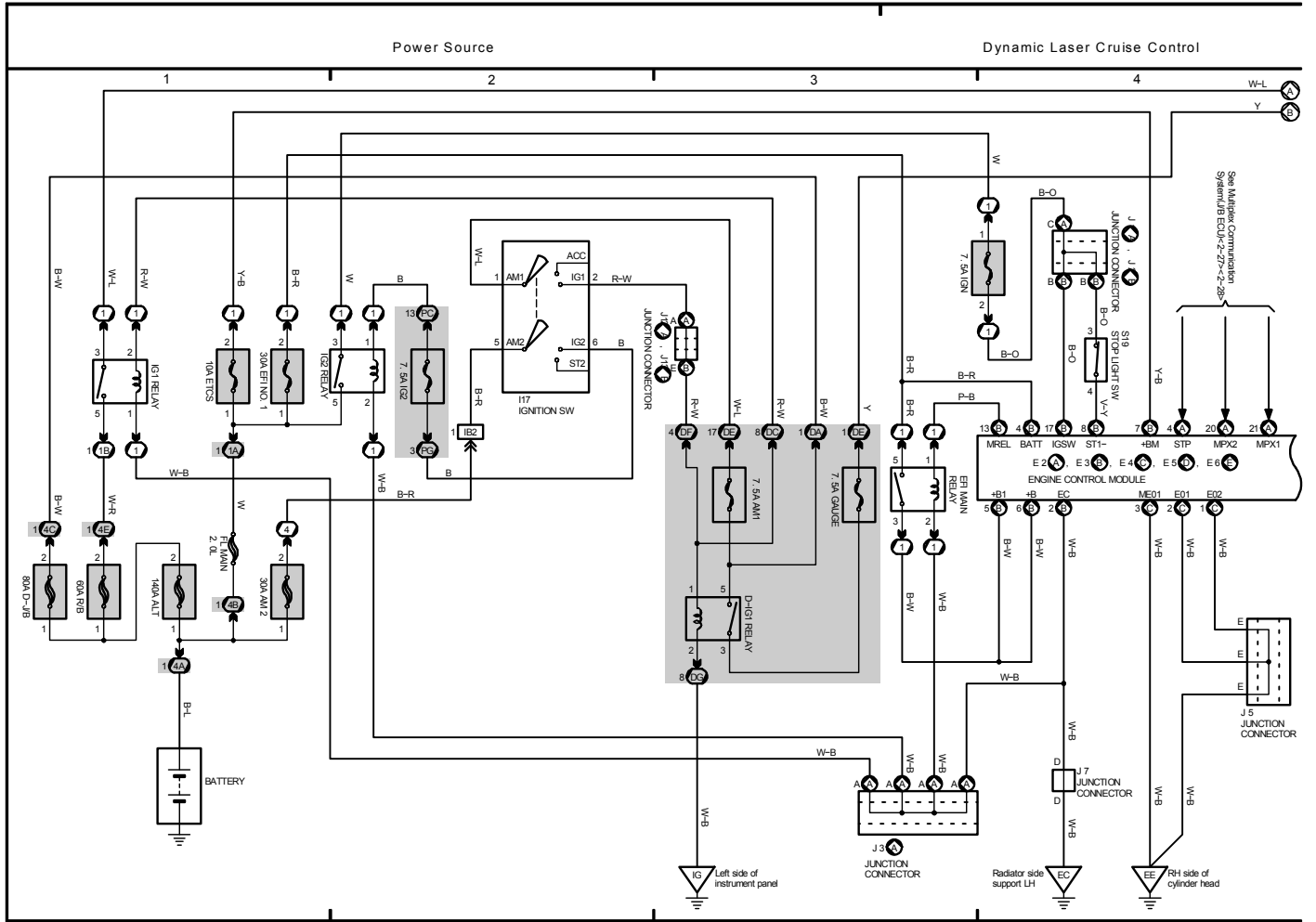

OVERALL ELECTRICAL WIRING DIAGRAM

Dynamic Laser Cruise Control

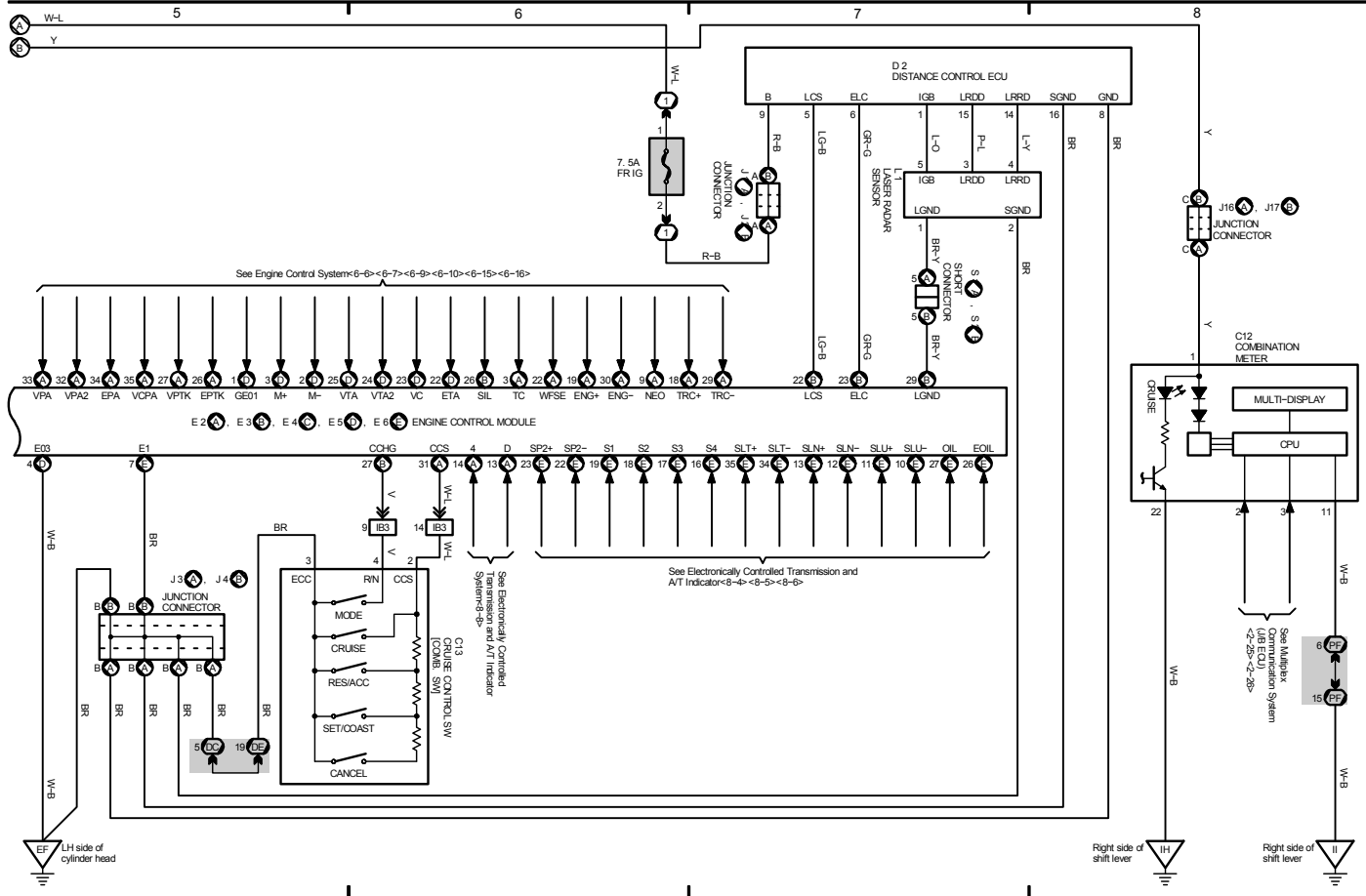

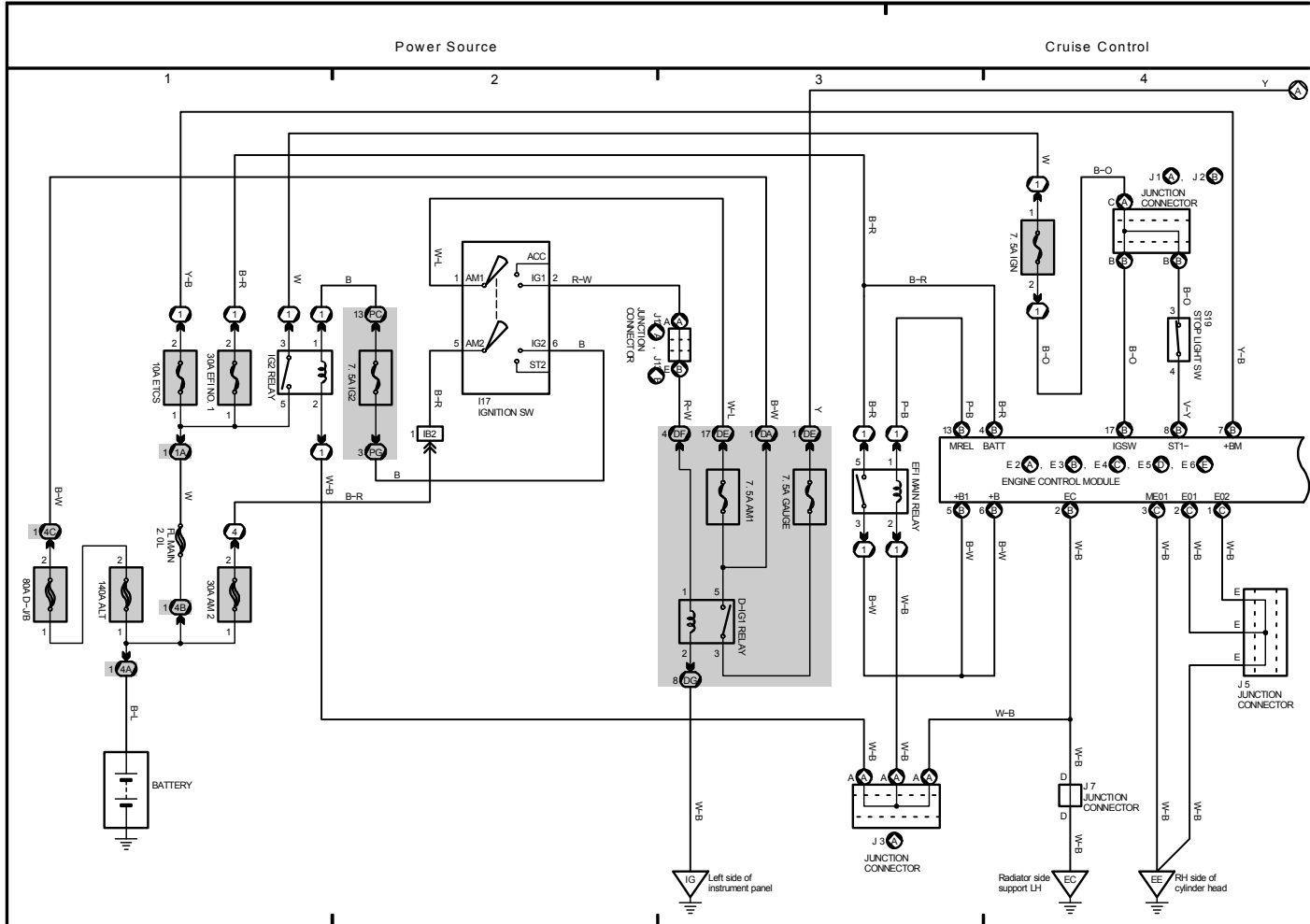

Cruise Control

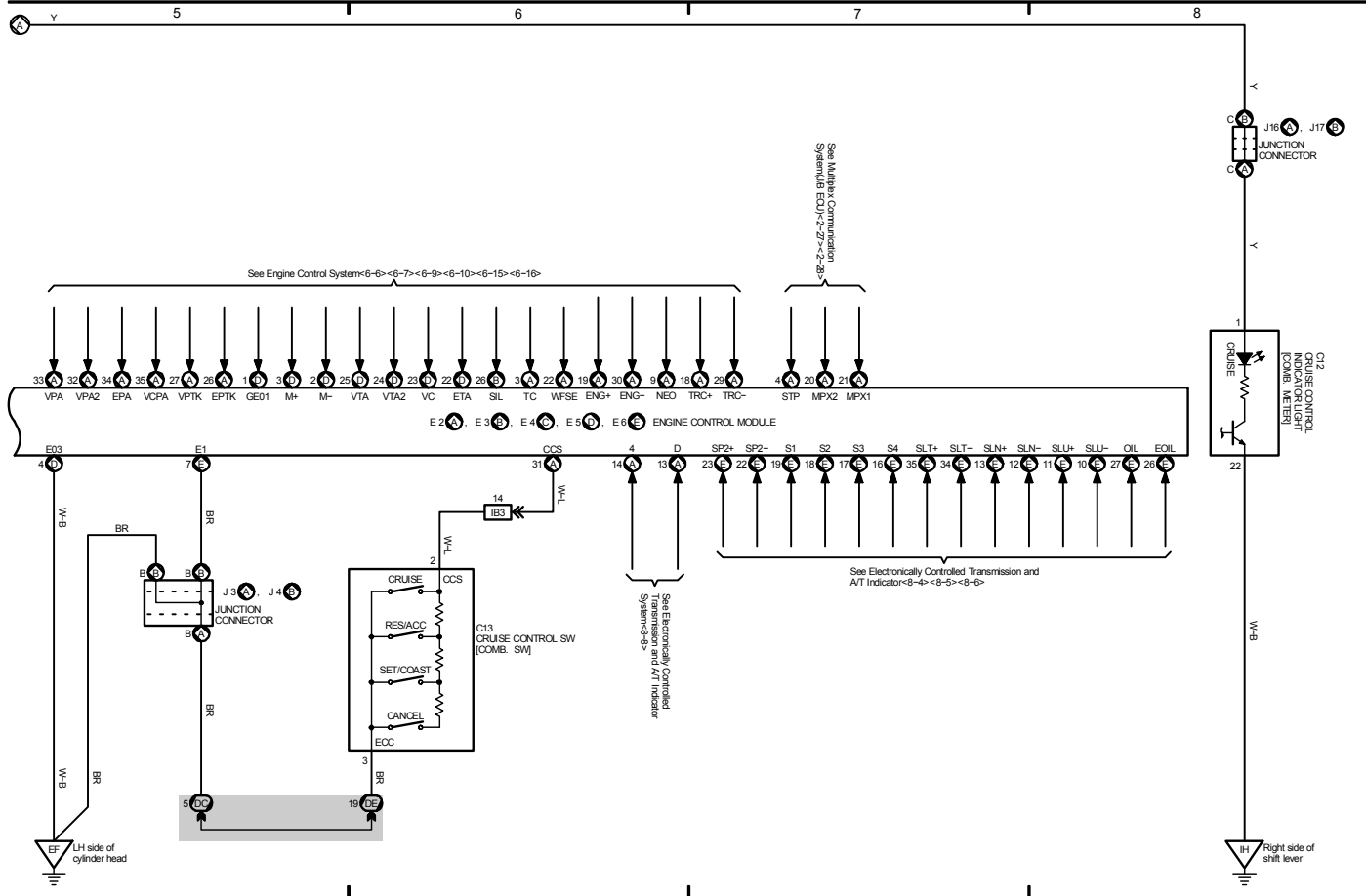

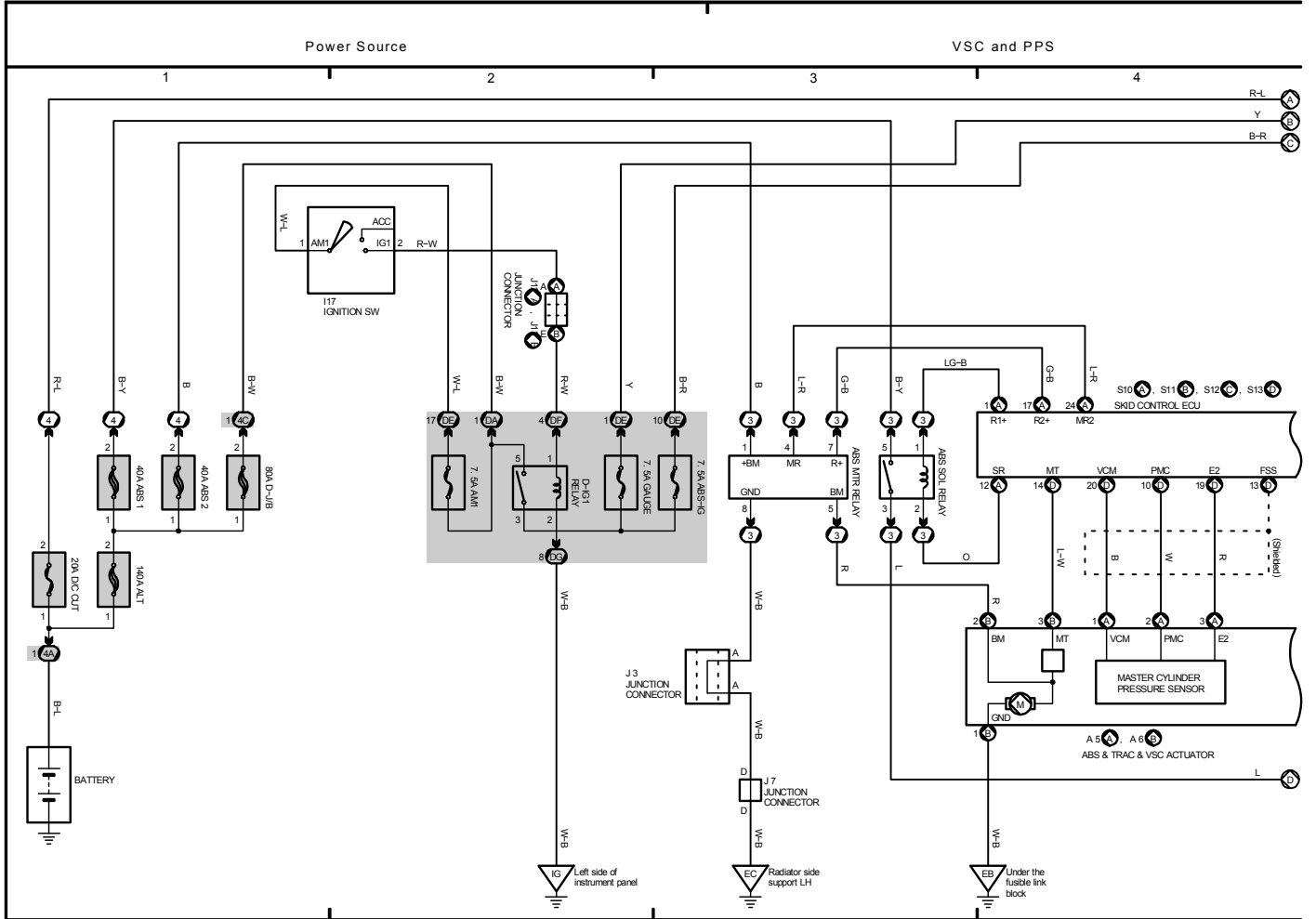

VSC and PPS

* 1 : w/ LEXUS Navigation System
 * 2 : w/ Electronic Modulated Air Suspension

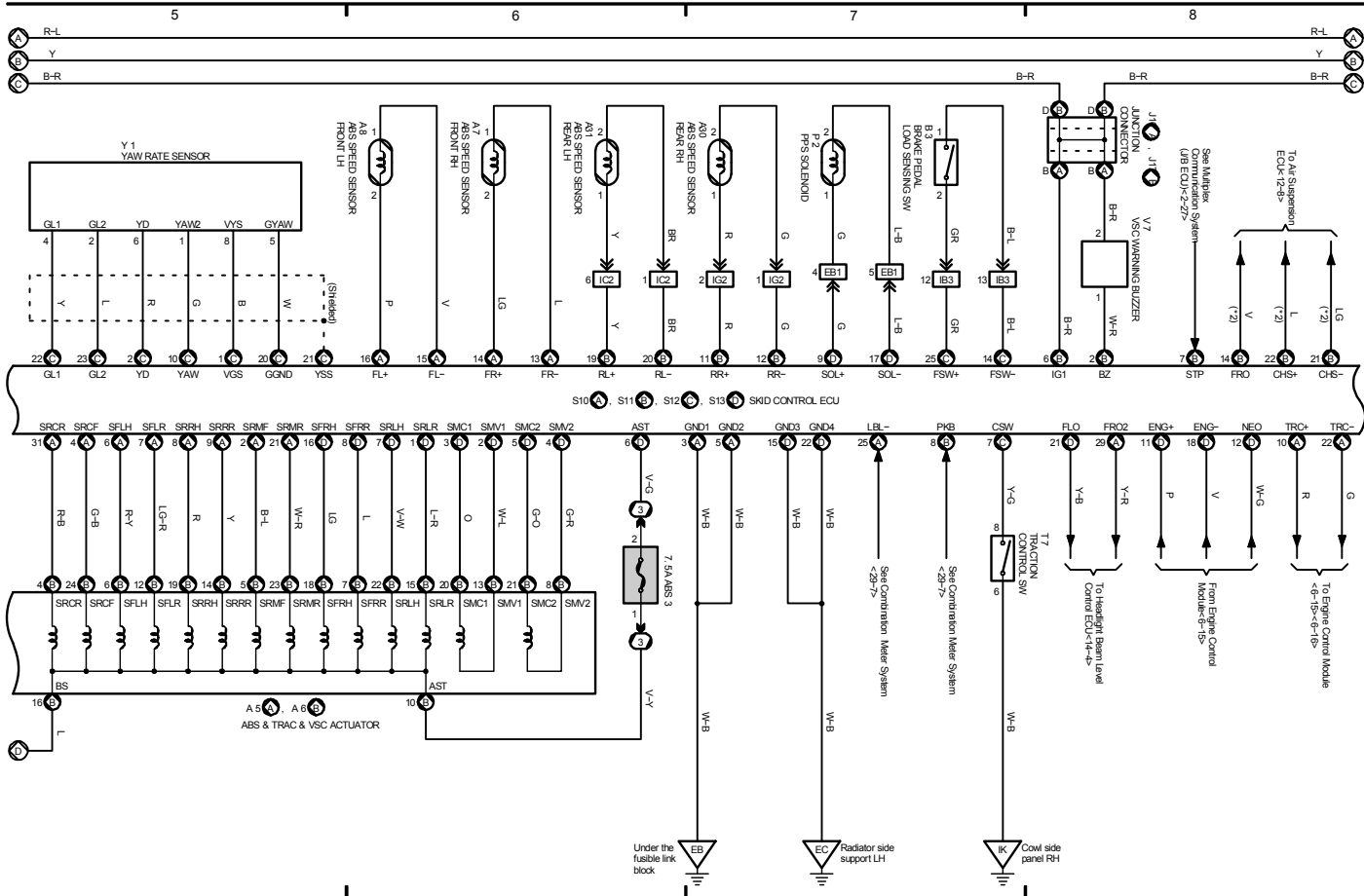

M OVERALL ELECTRICAL WIRING DIAGRAM

11 LS 430 (Cont' d)

VSC and PPS

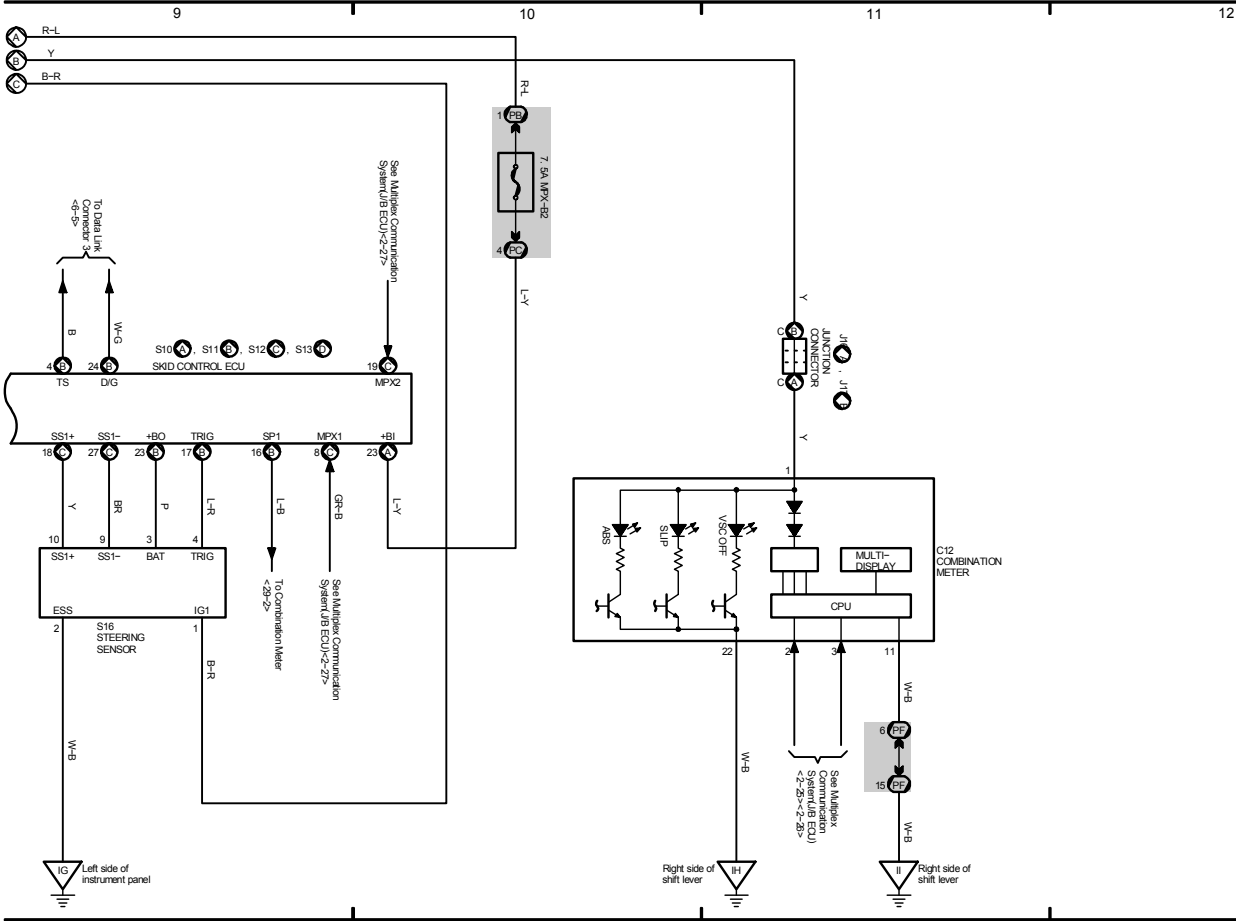

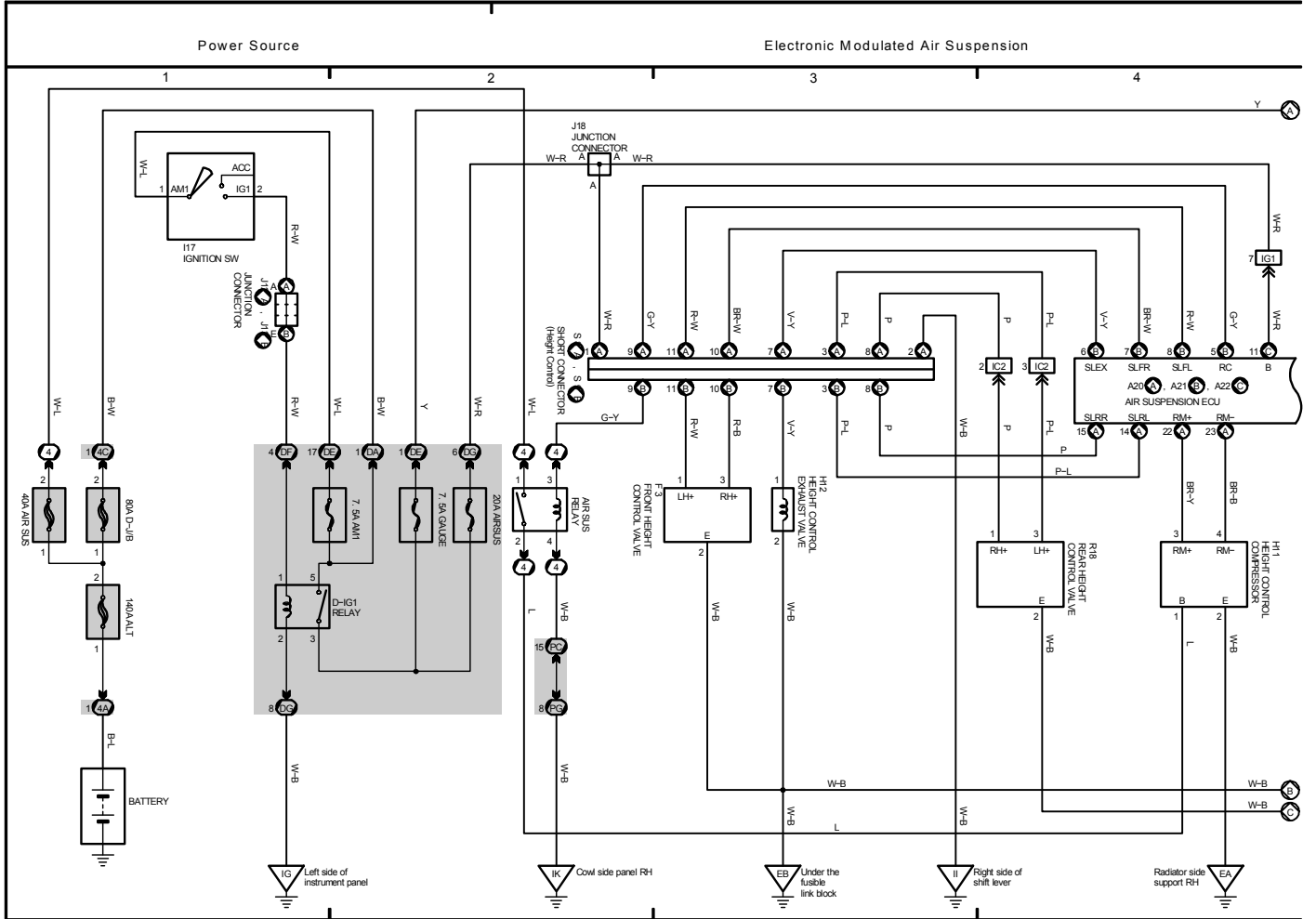

M OVERALL ELECTRICAL WIRING DIAGRAM

Electronic Modulated Air Suspension

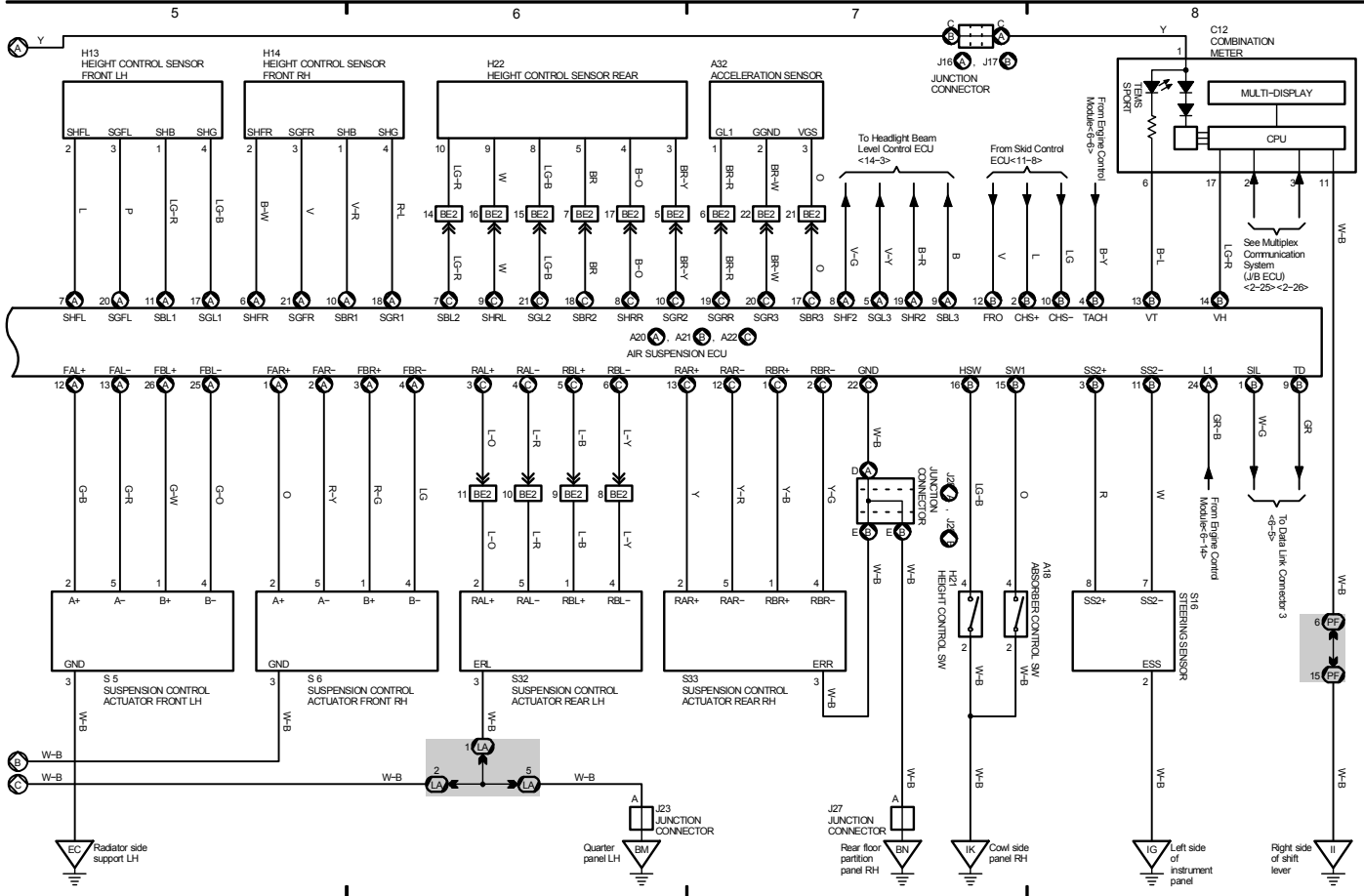

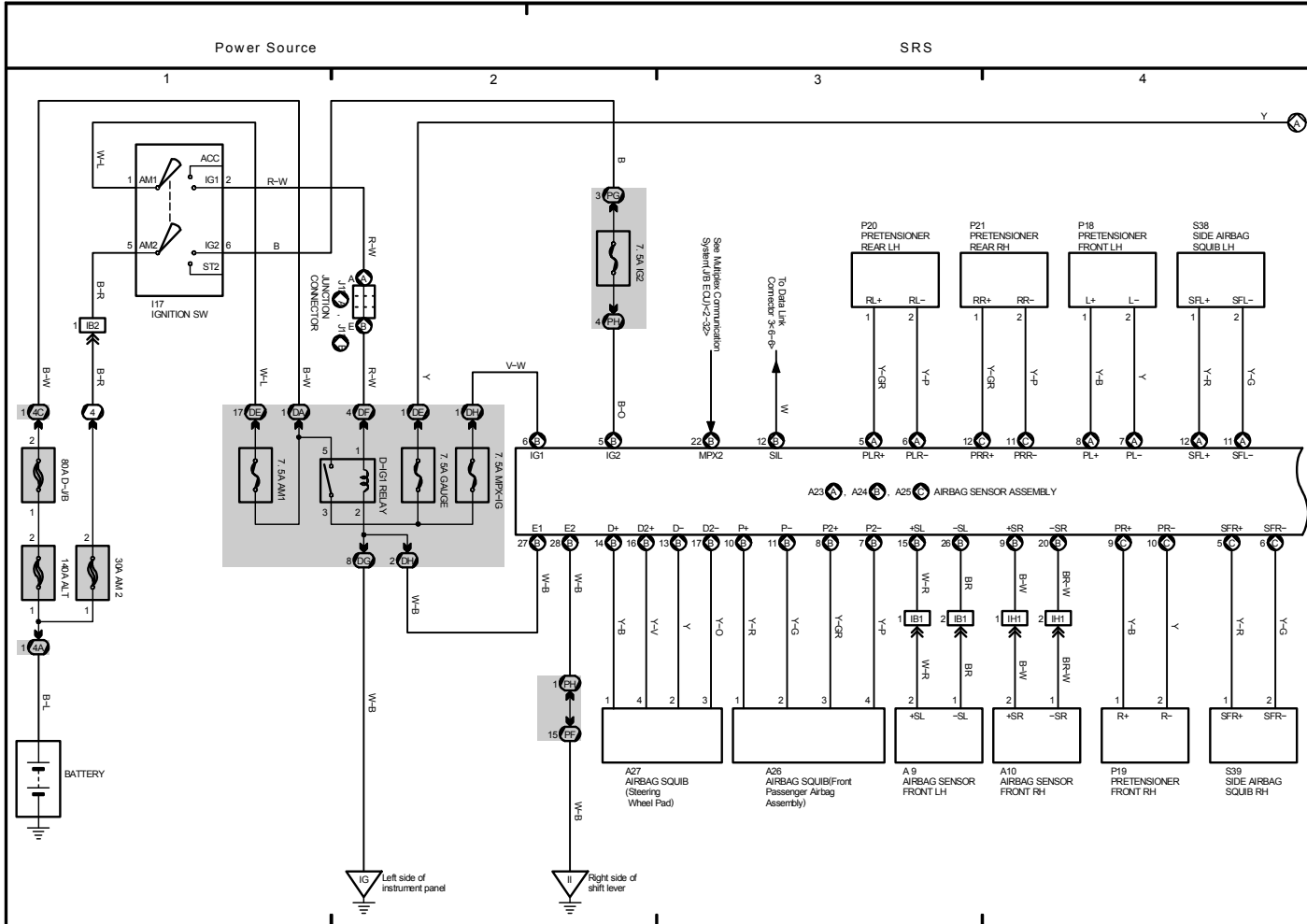

SRS

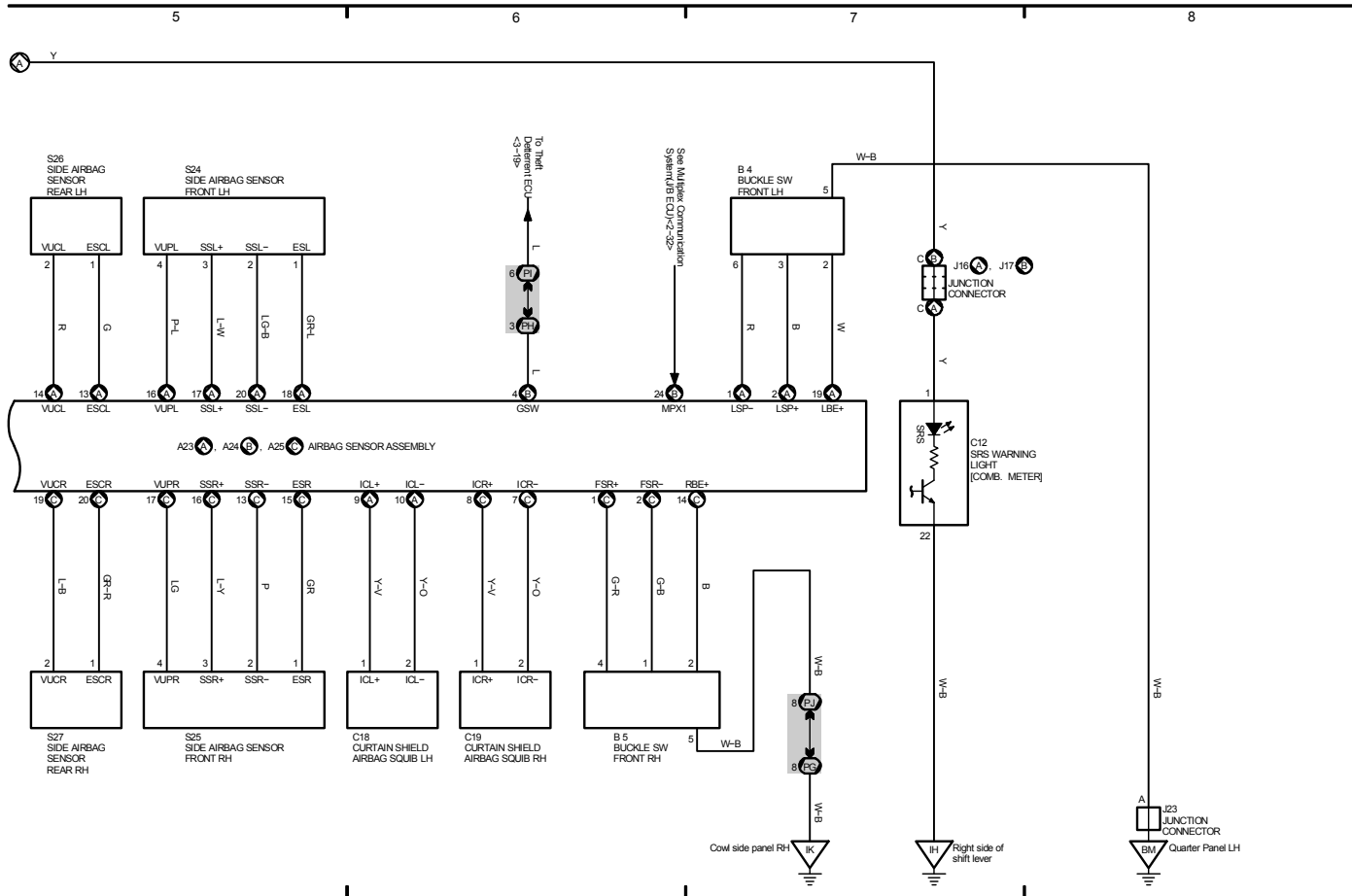

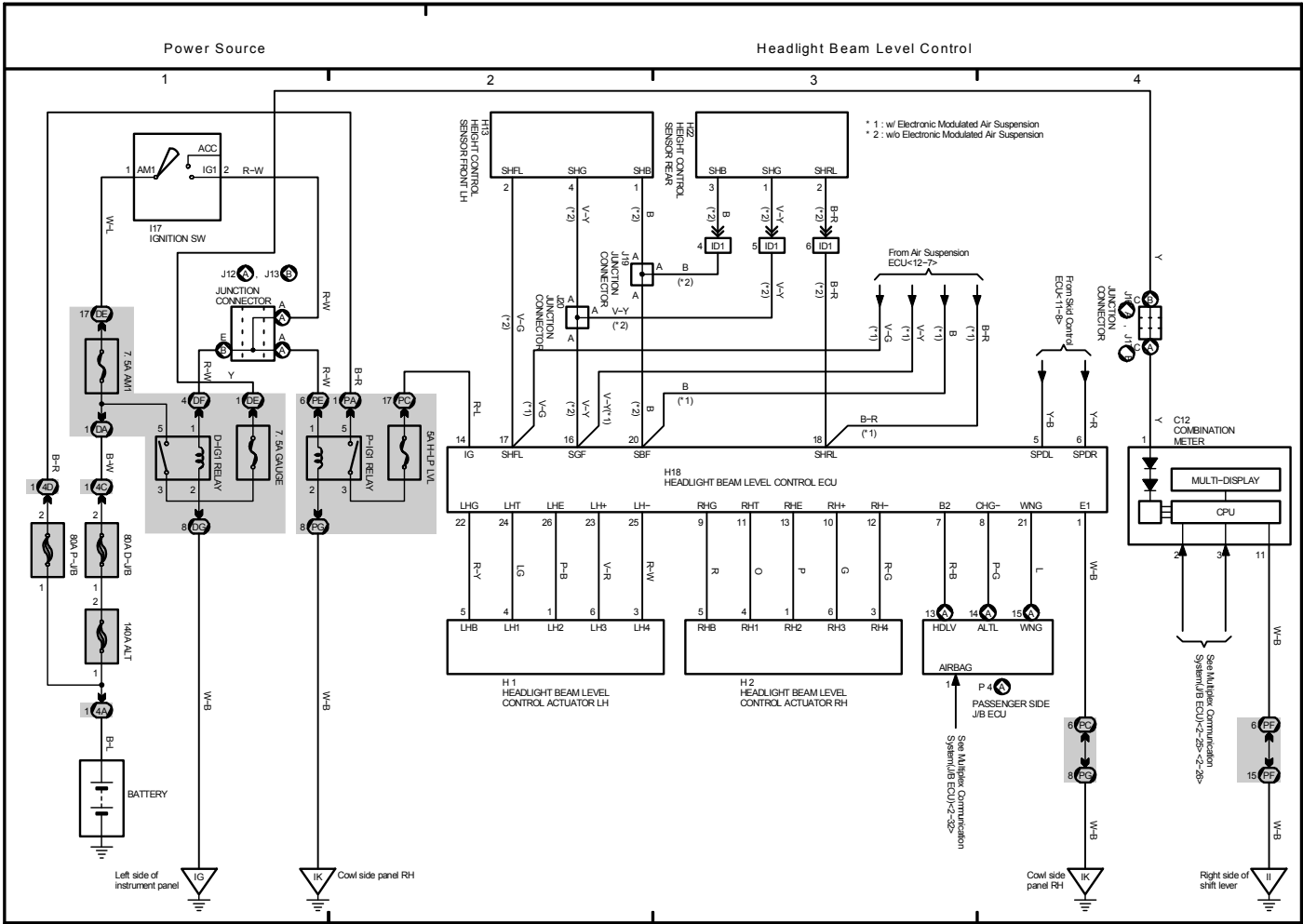

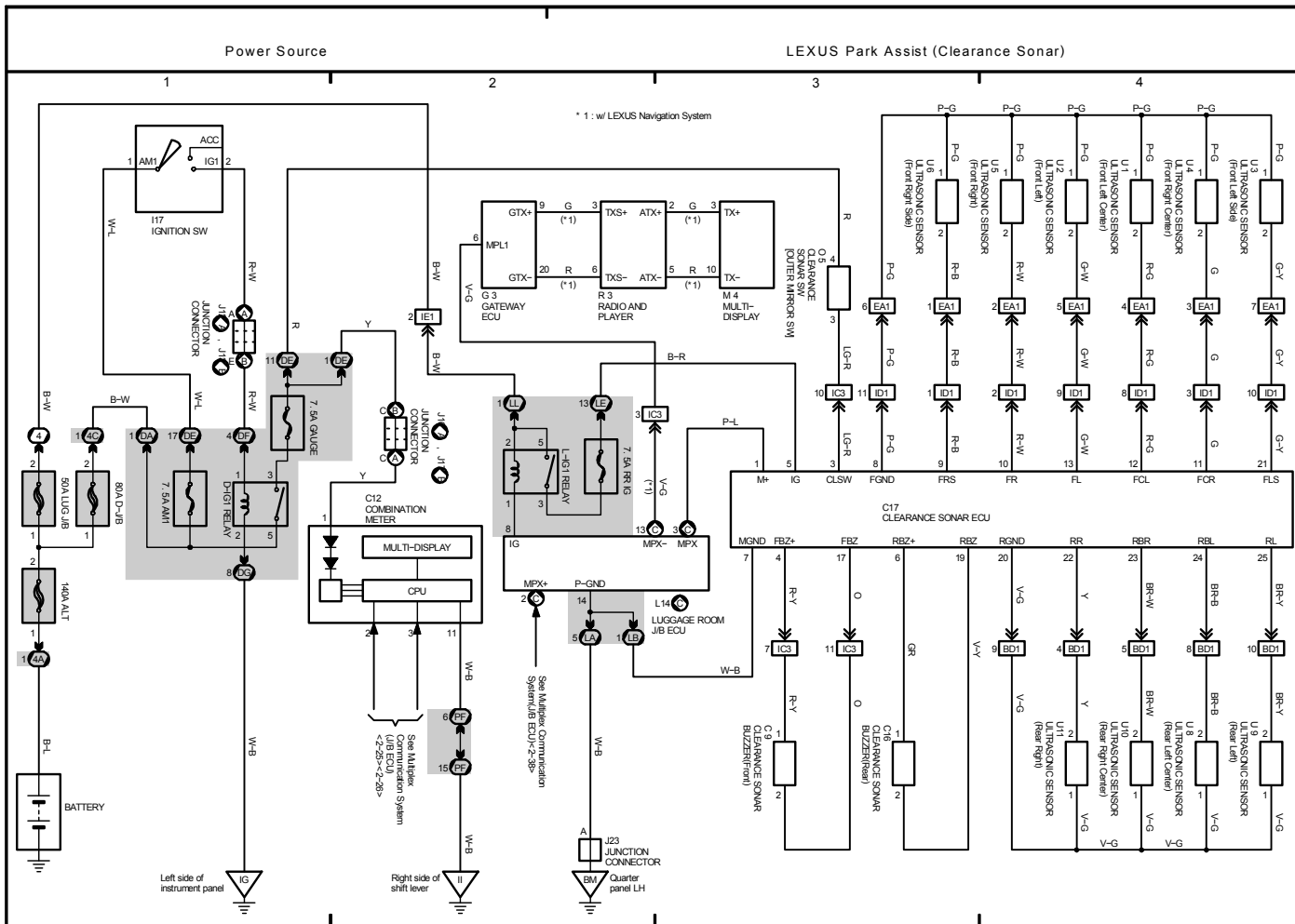

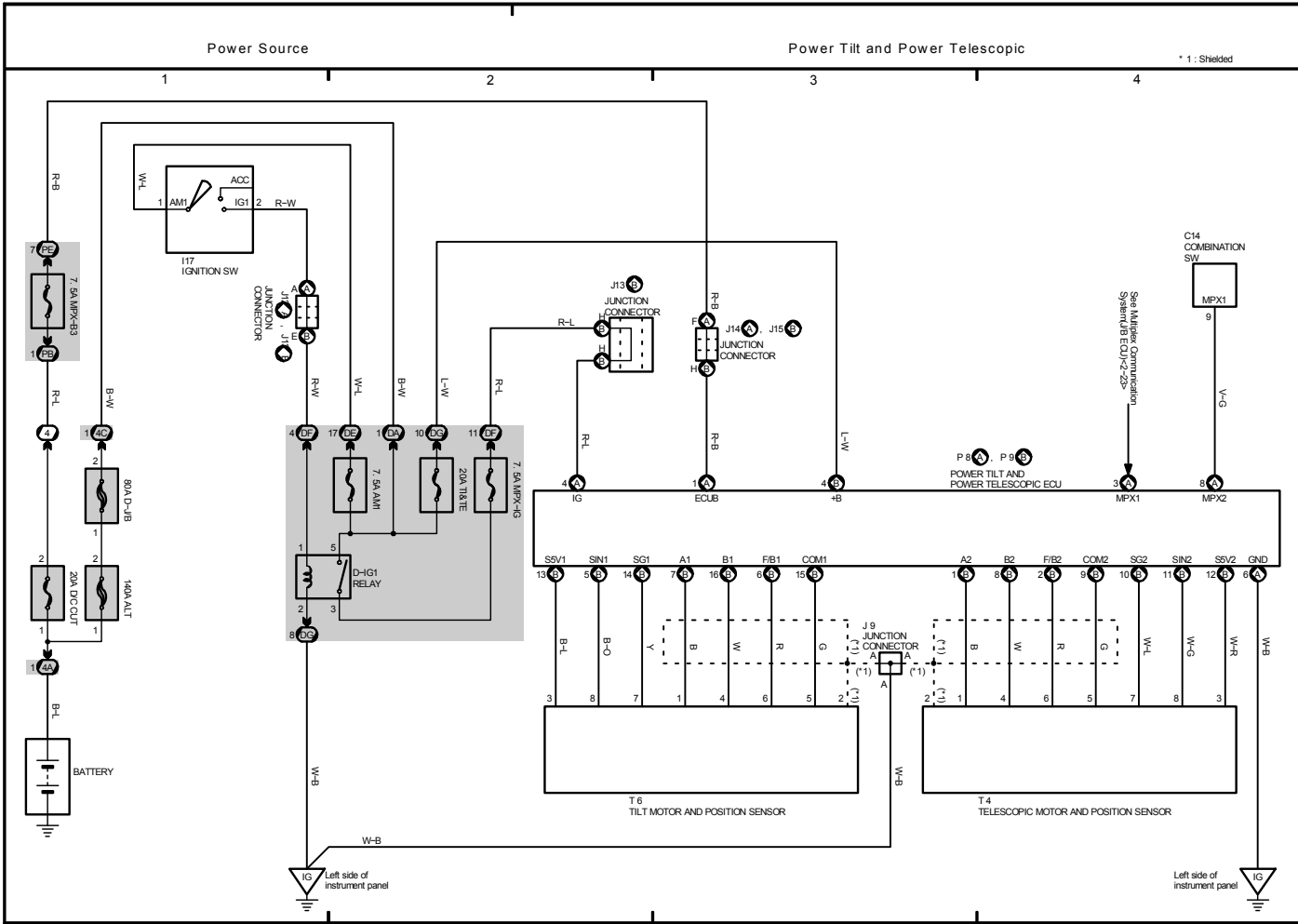

M OVERALL ELECTRICAL WIRING DIAGRAM

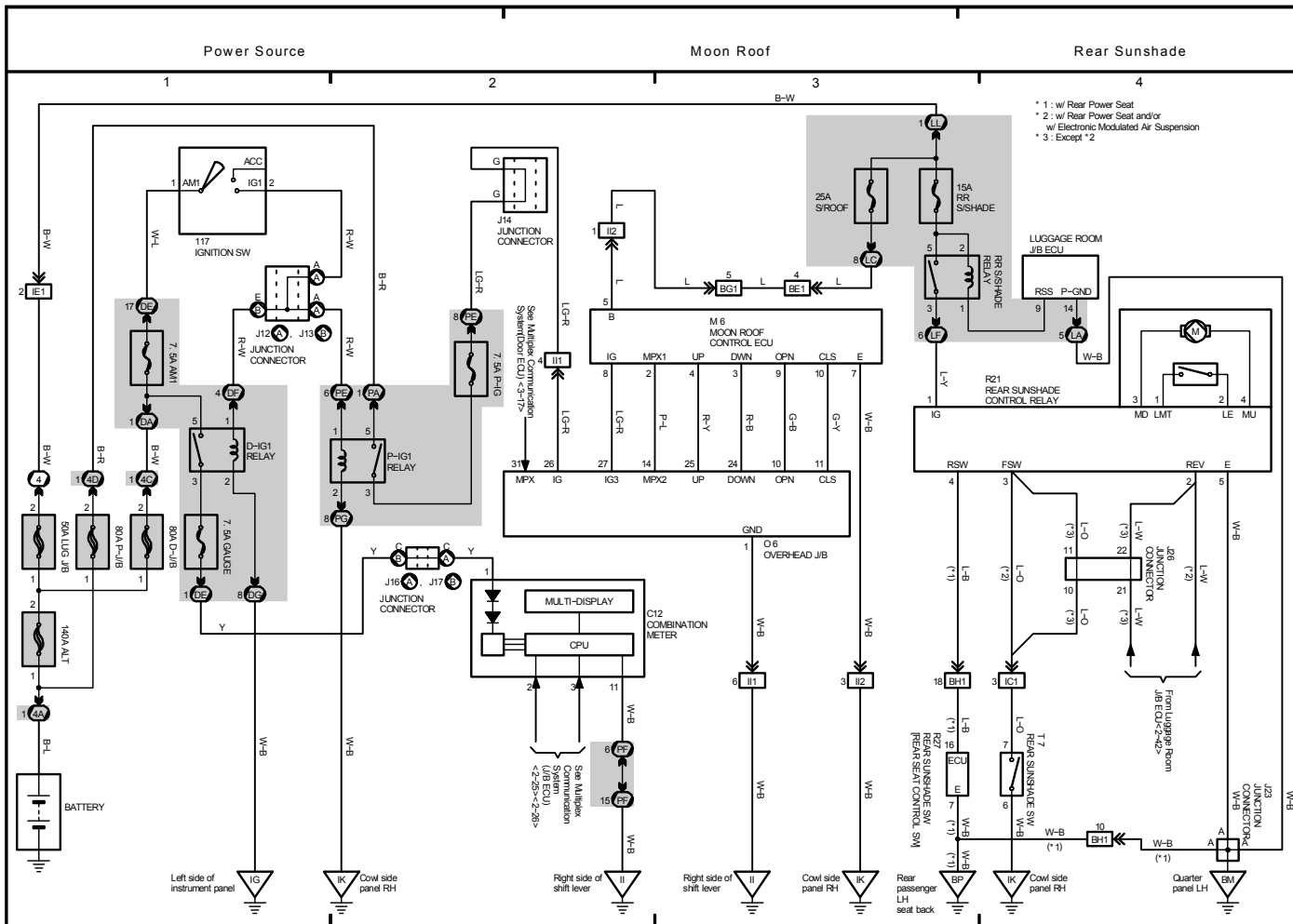

- * 1 : w/ Rear Power Seat
- * 2 : w/ Rear Power Seat and/or w/ Electronic Modulated Air Suspension
- * 3 : Except *2

Left side of instrument panel

Cowl side panel RH

Right side of shift lever

Right side of shift lever

Cowl side panel RH

Rear passenger LH seat back

Cowl side panel RH

Quarter panel LH

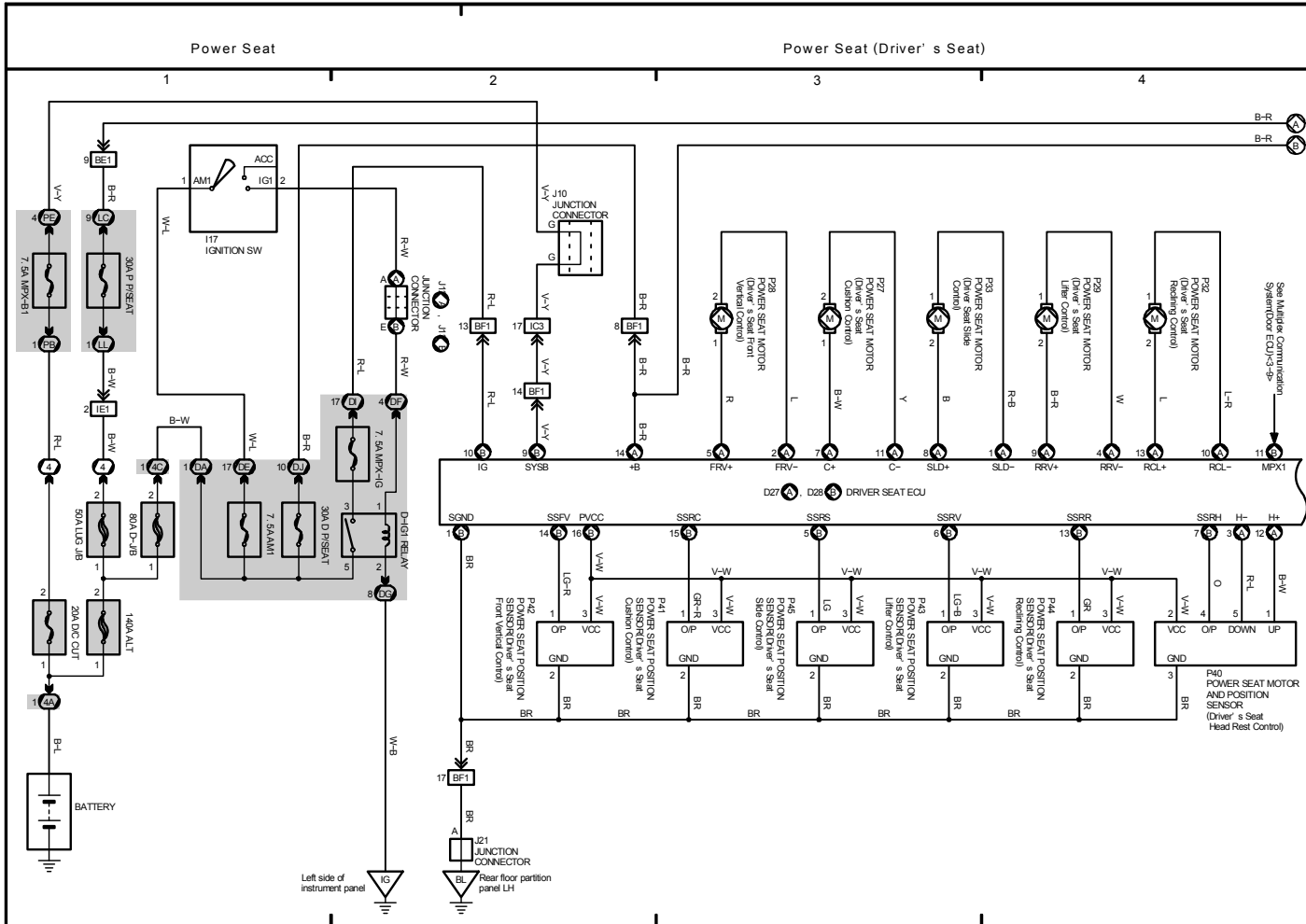

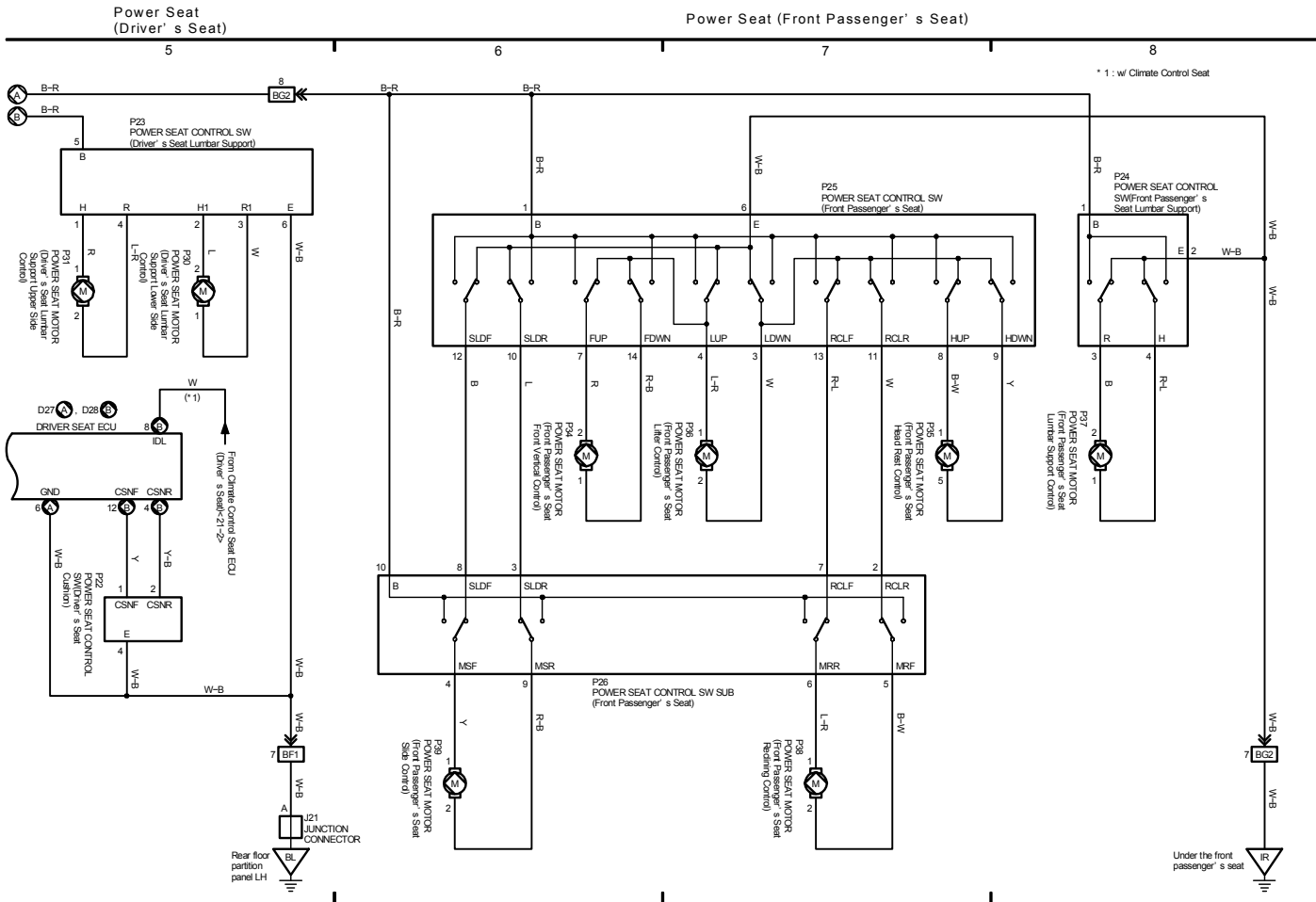

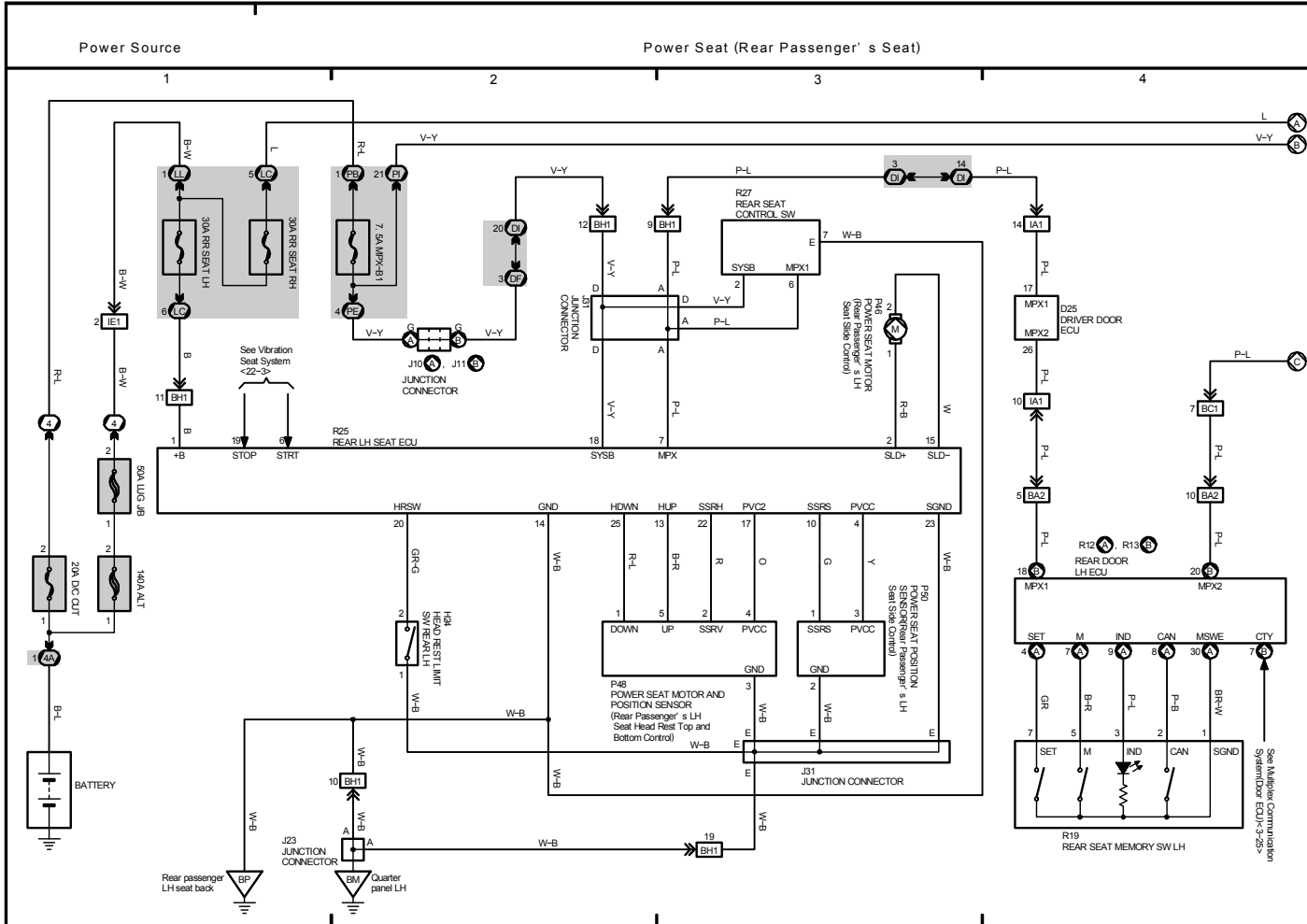

Power Seat (Rear Passenger's Seat)

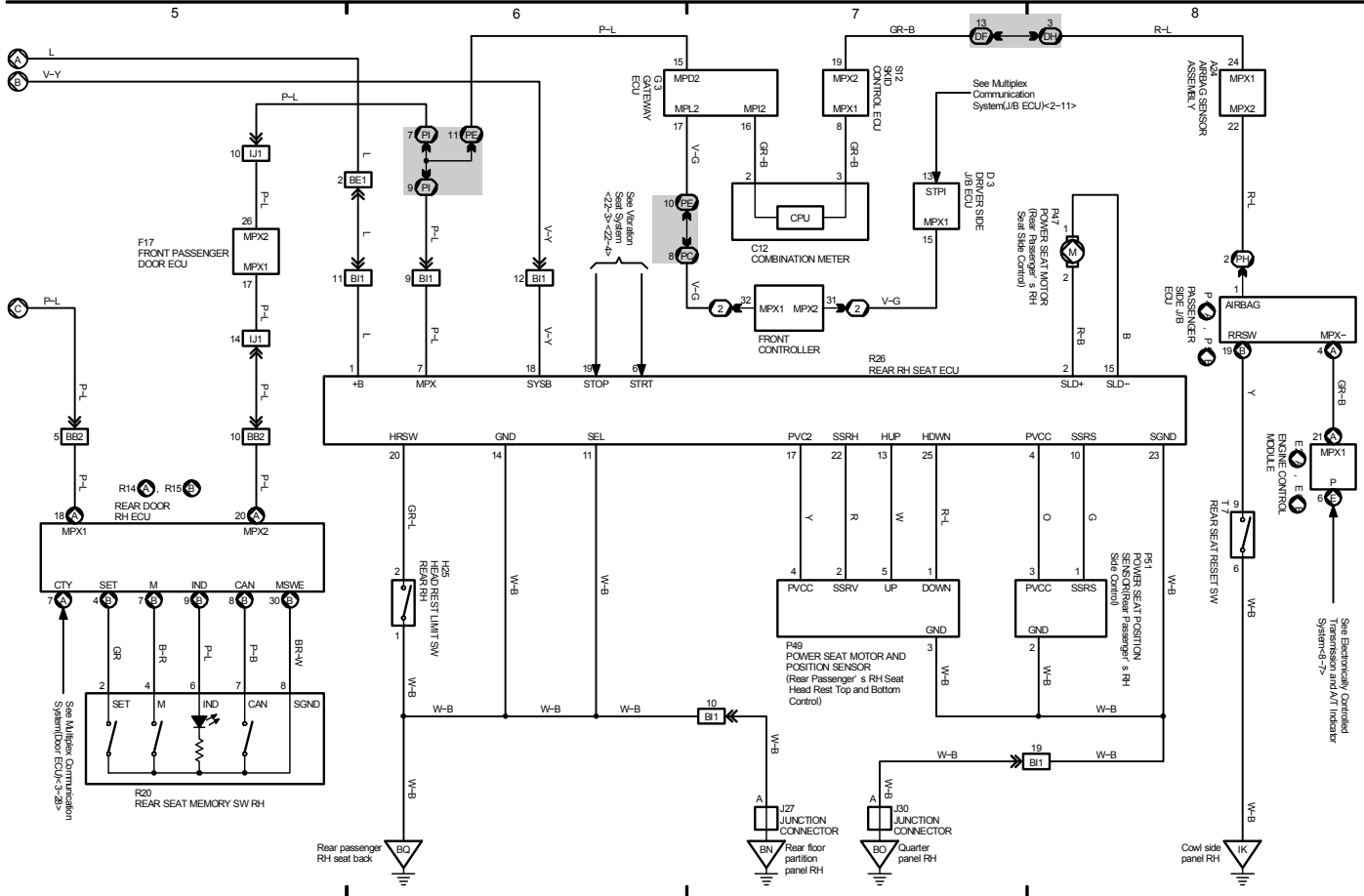

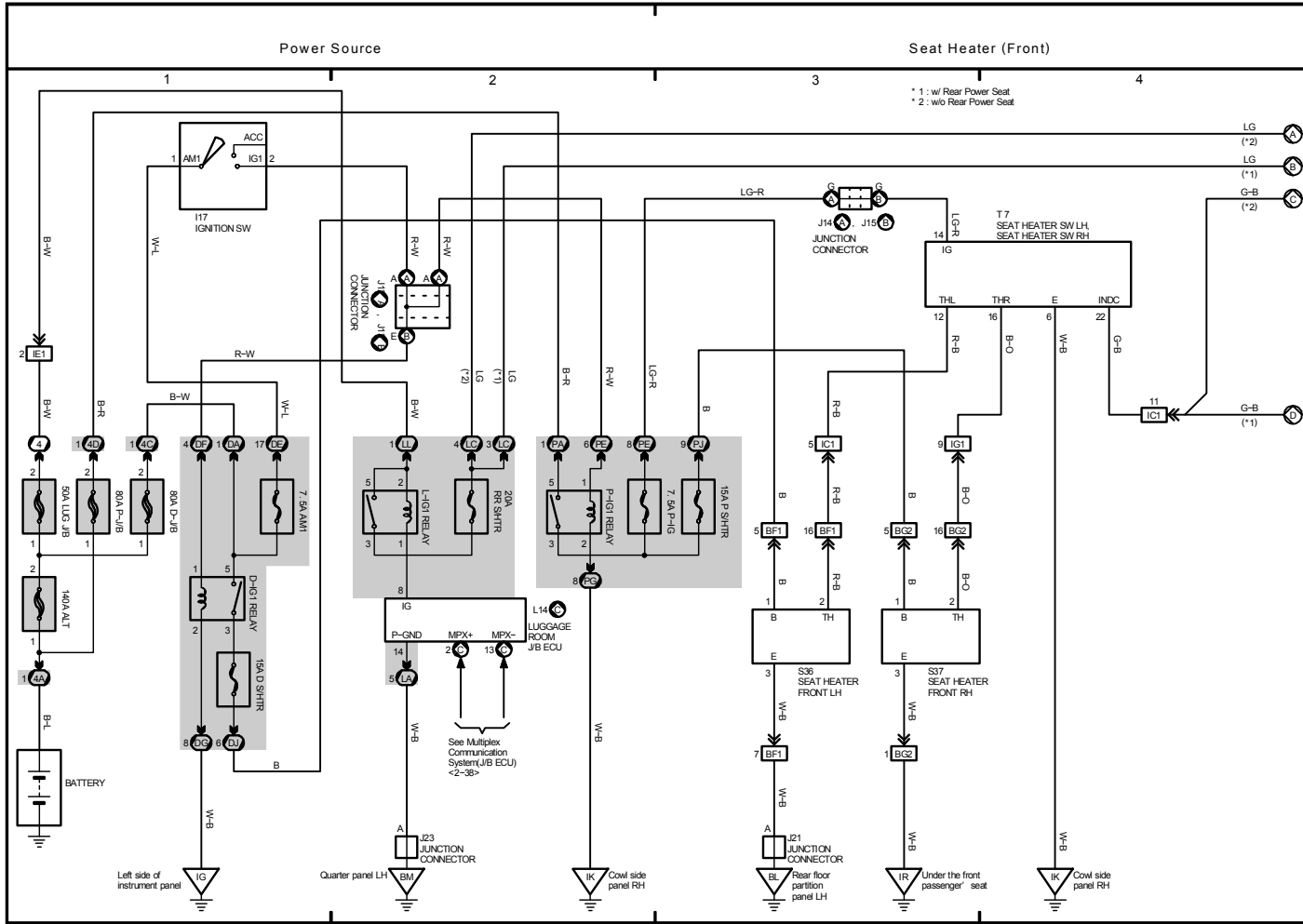

OVERALL ELECTRICAL WIRING DIAGRAM

Seat Heater (Rear)

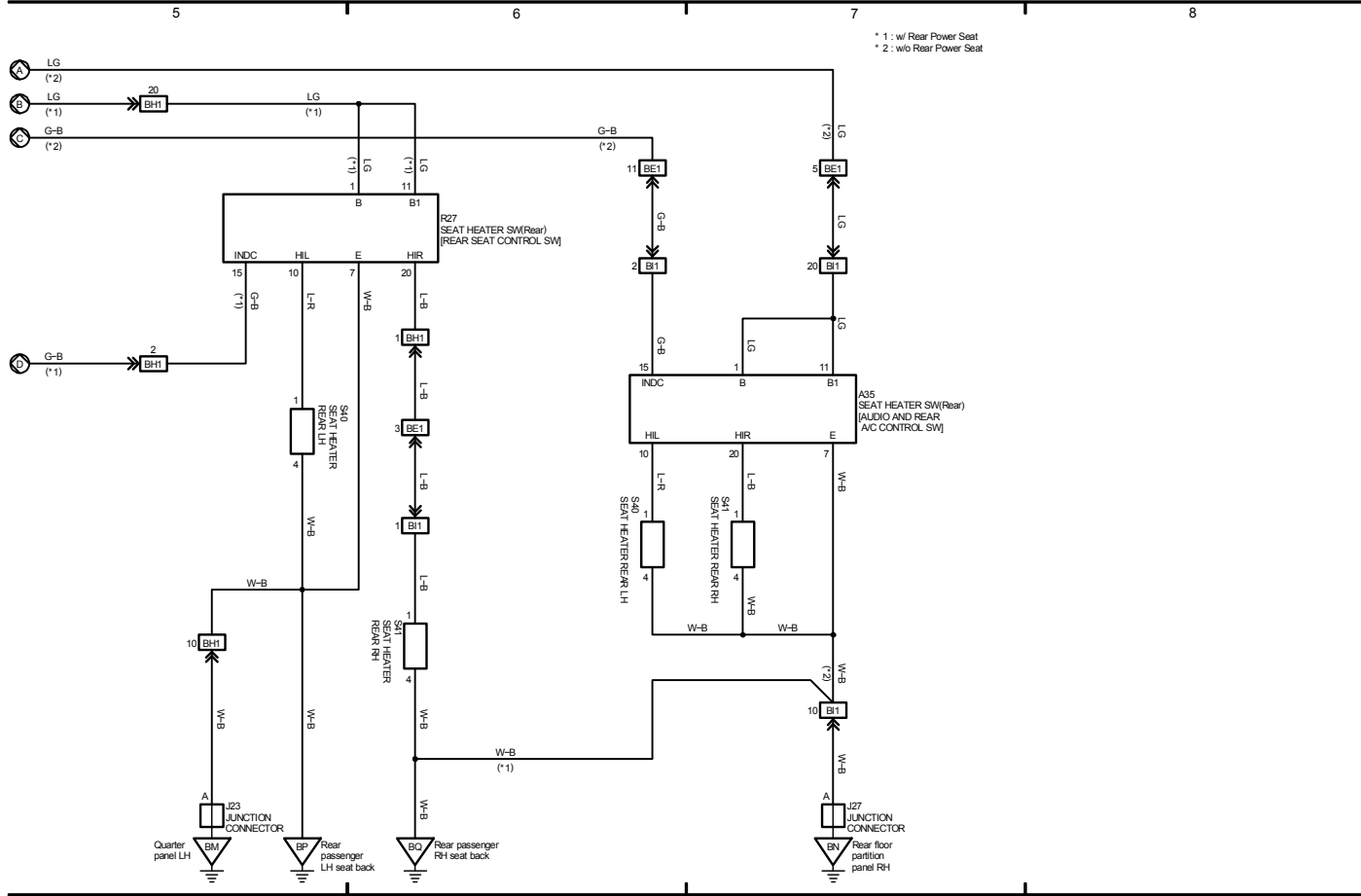

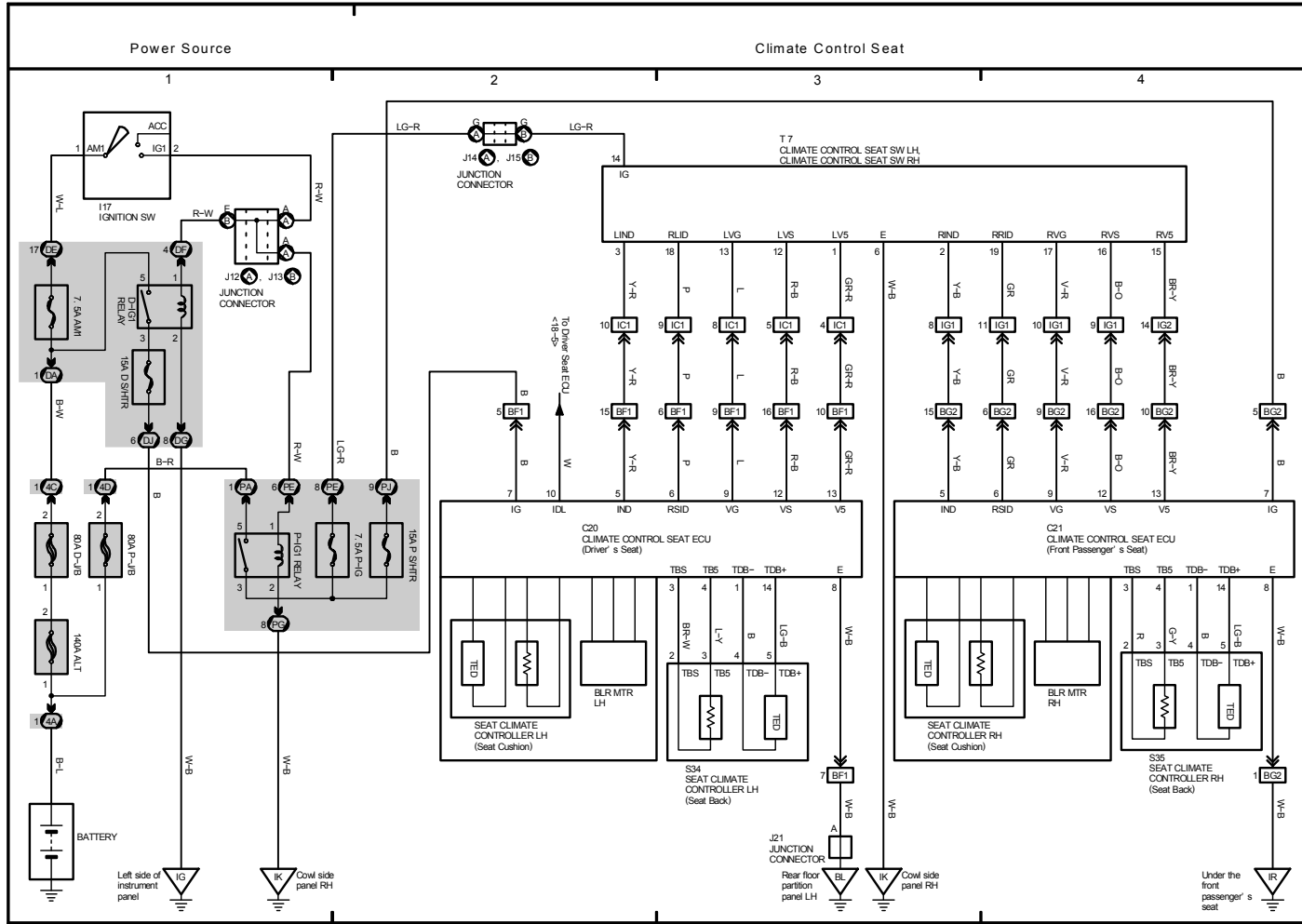

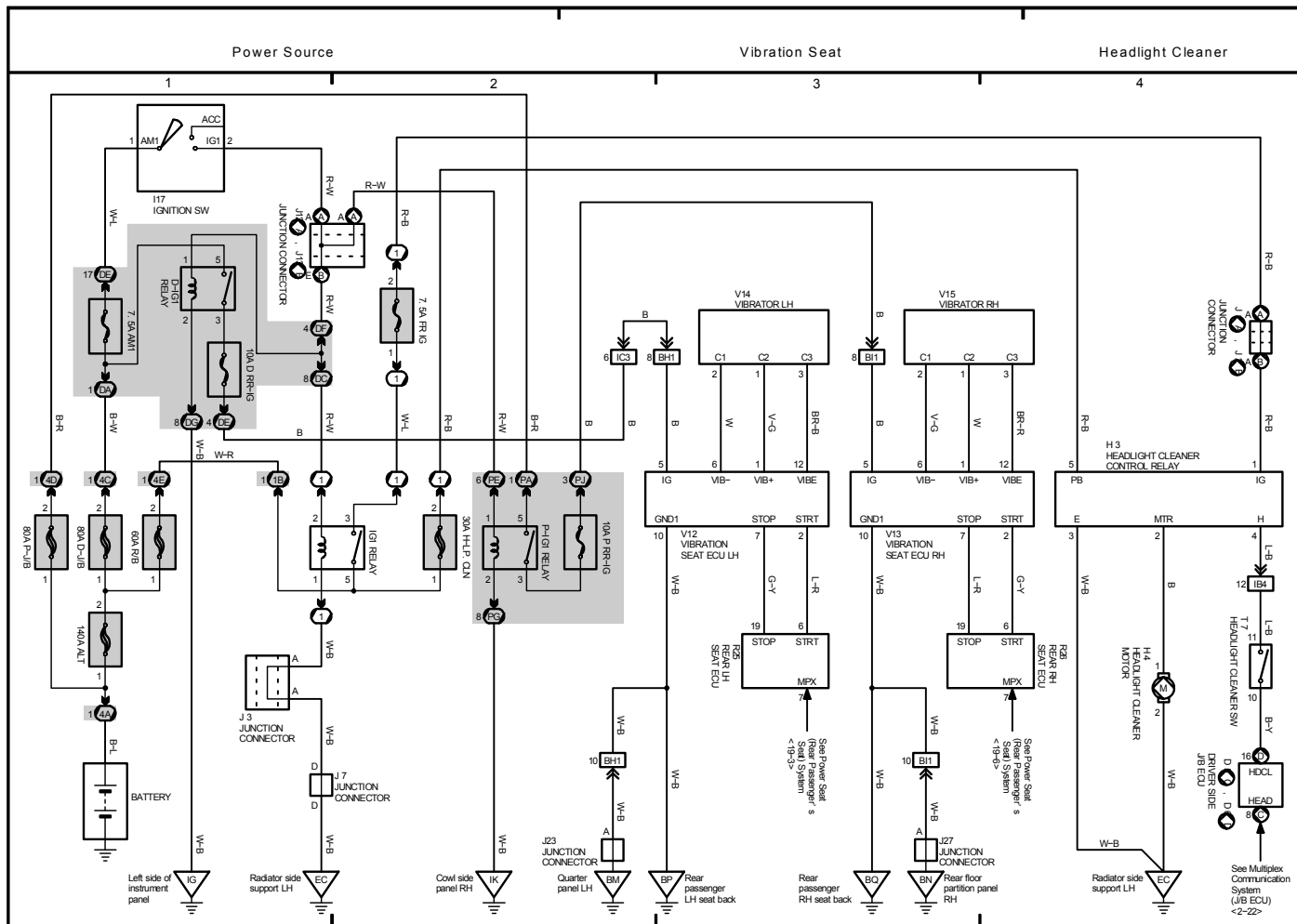

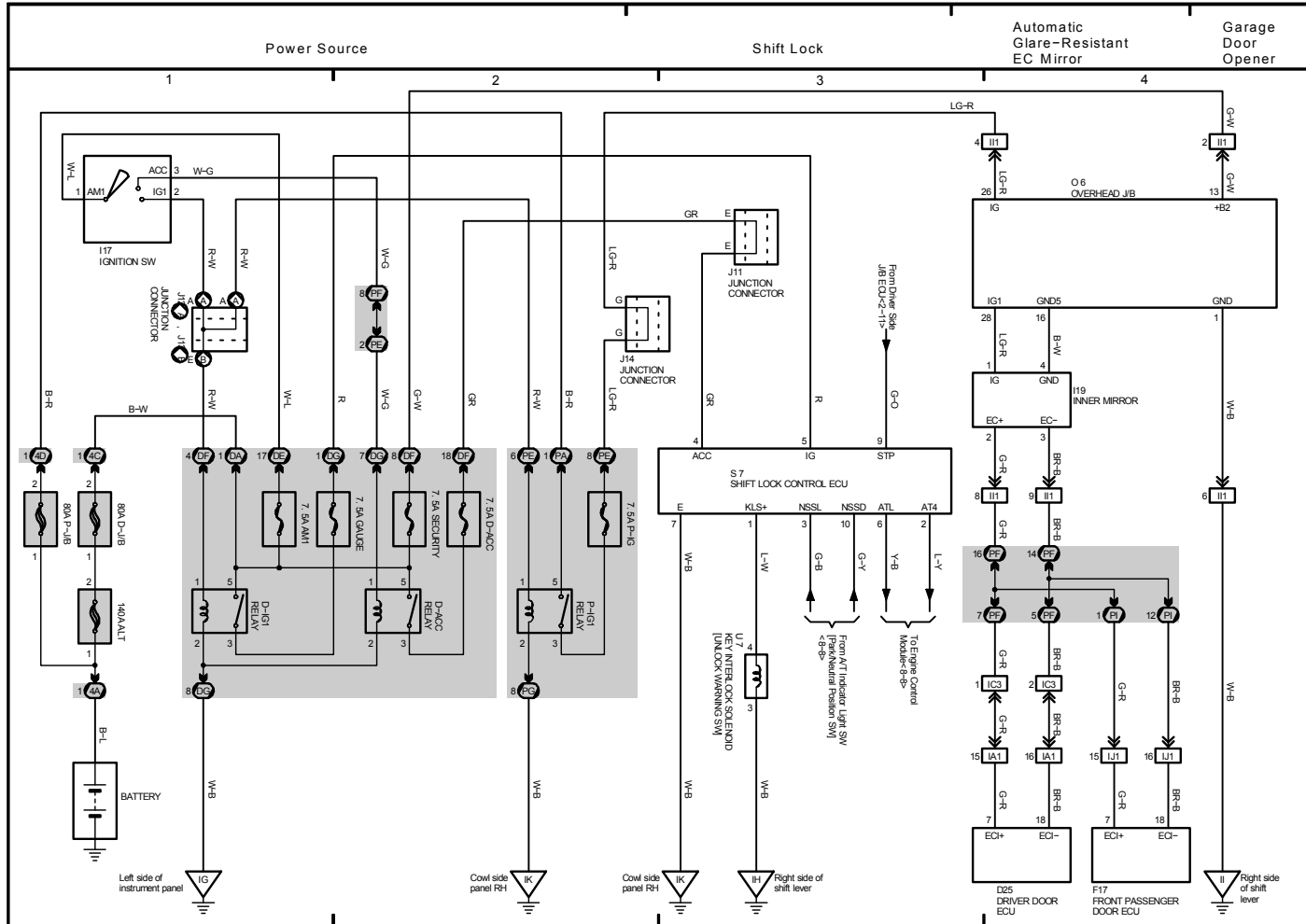

OVERALL ELECTRICAL WIRING DIAGRAM

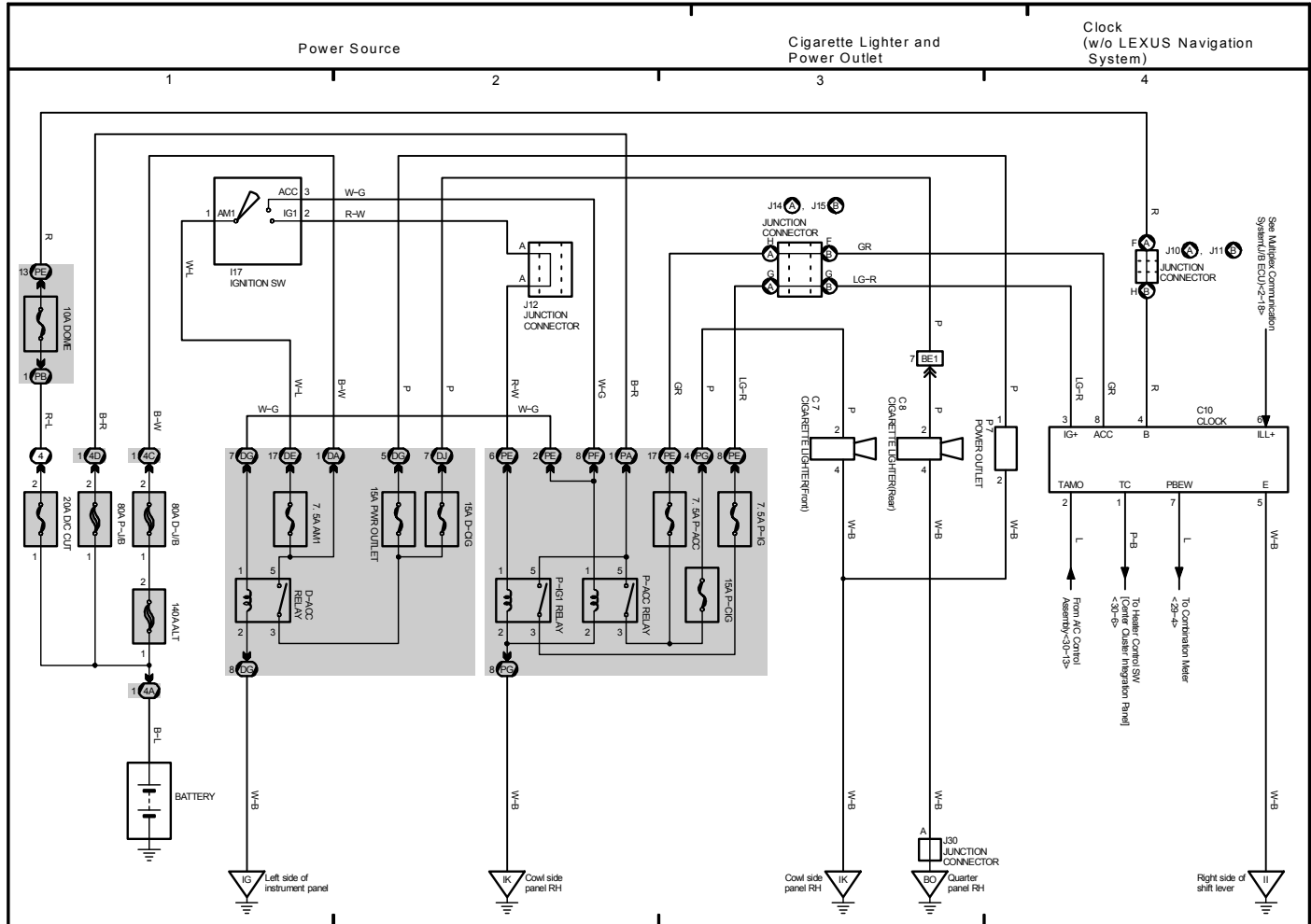

Power Source

Cellular Mobile Telephone and LEXUS Link System (Mayday System)

* 1: Shielded

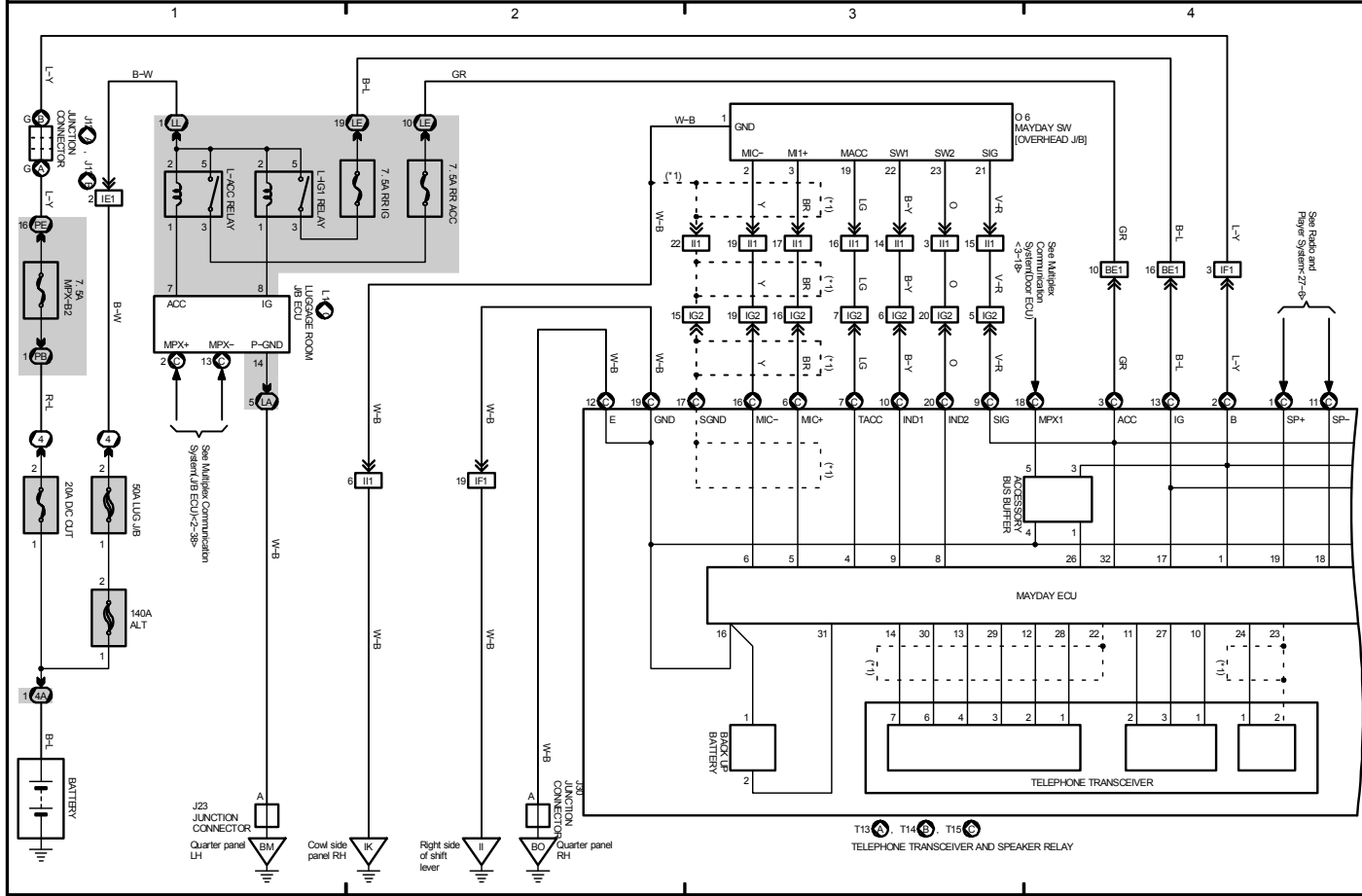

OVERALL ELECTRICAL WIRING DIAGRAM

Cellular Mobile Telephone and LEXUS Link System (Mayday System)

* 1: Shielded

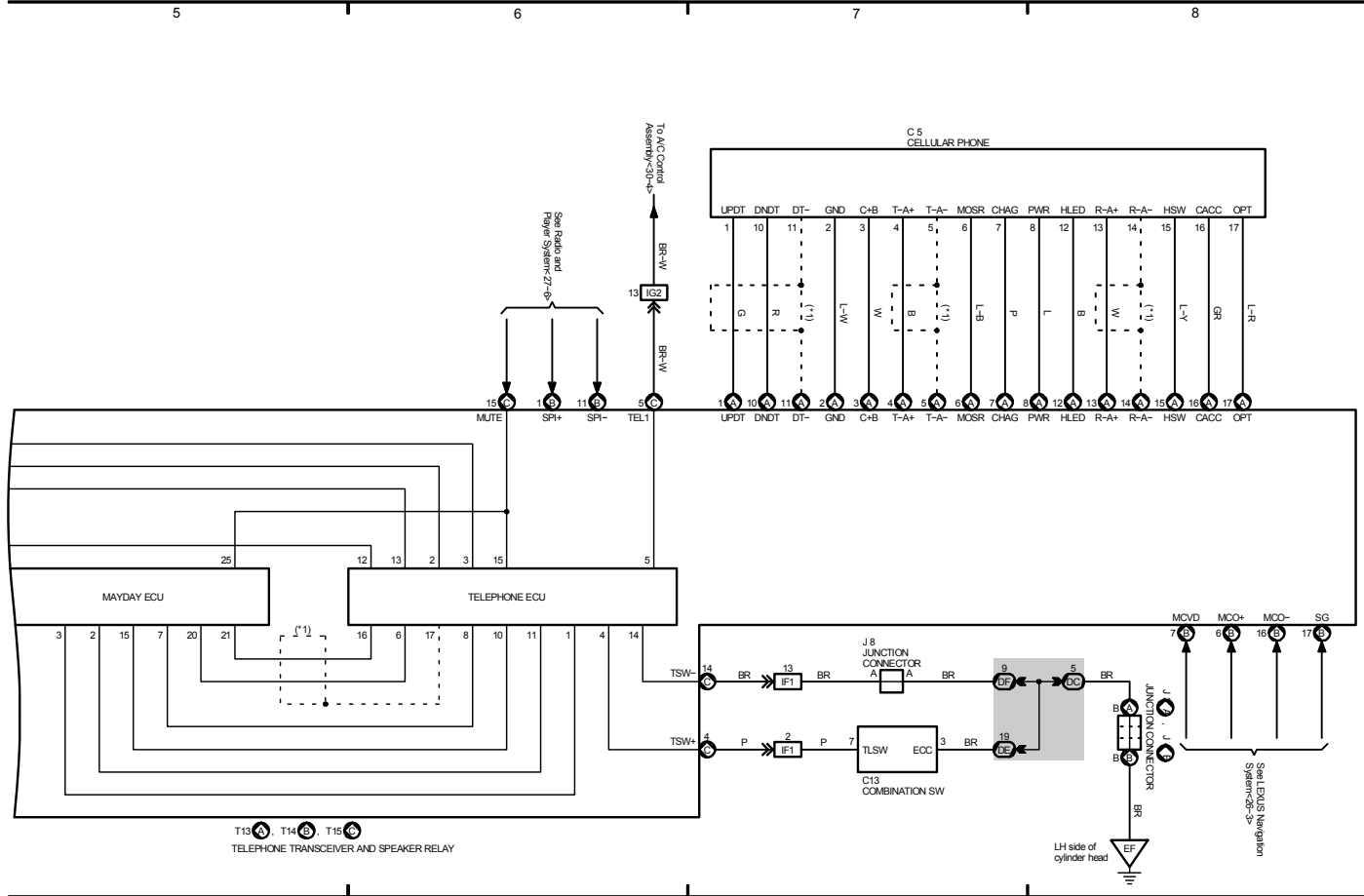

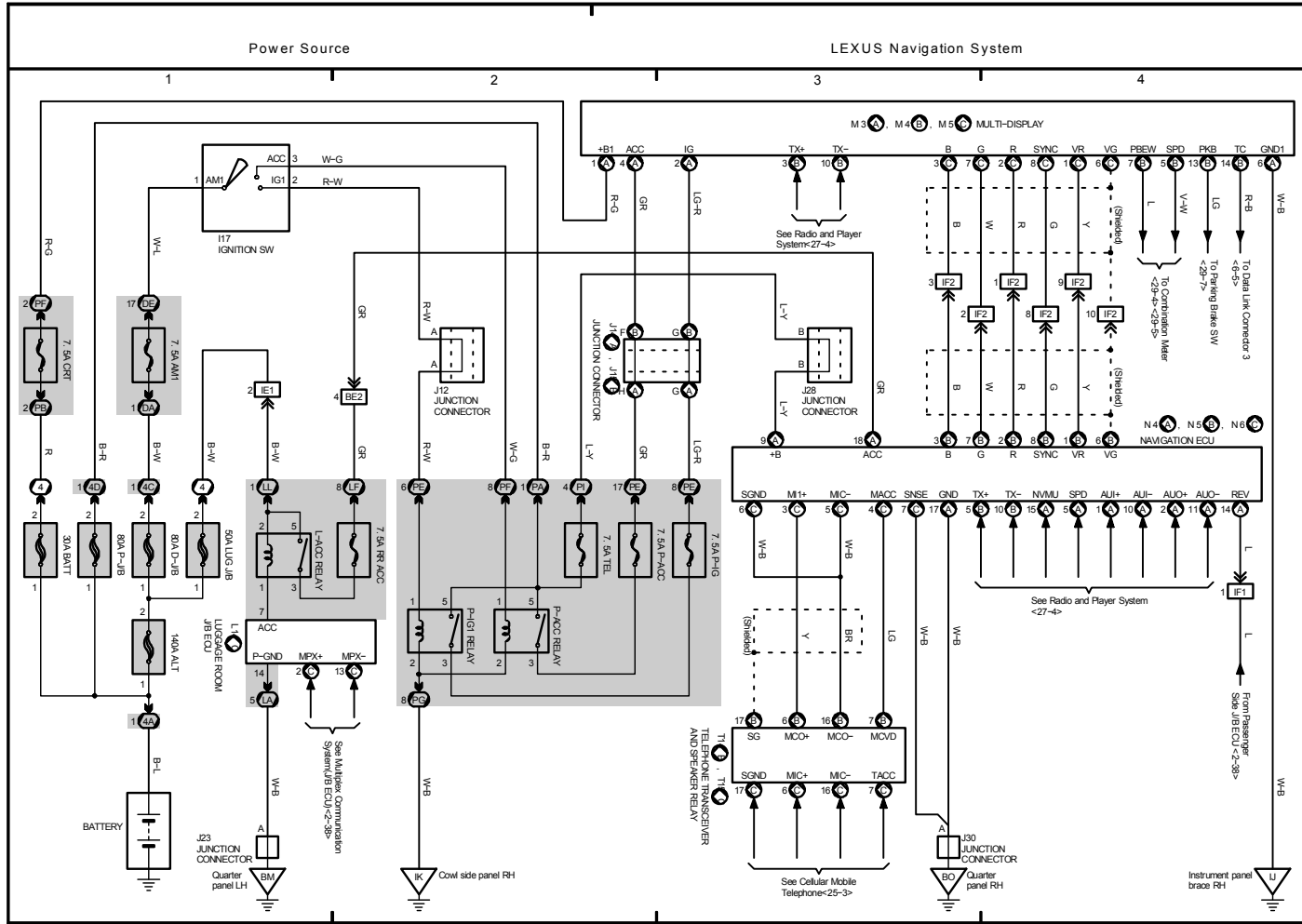

M OVERALL ELECTRICAL WIRING DIAGRAM

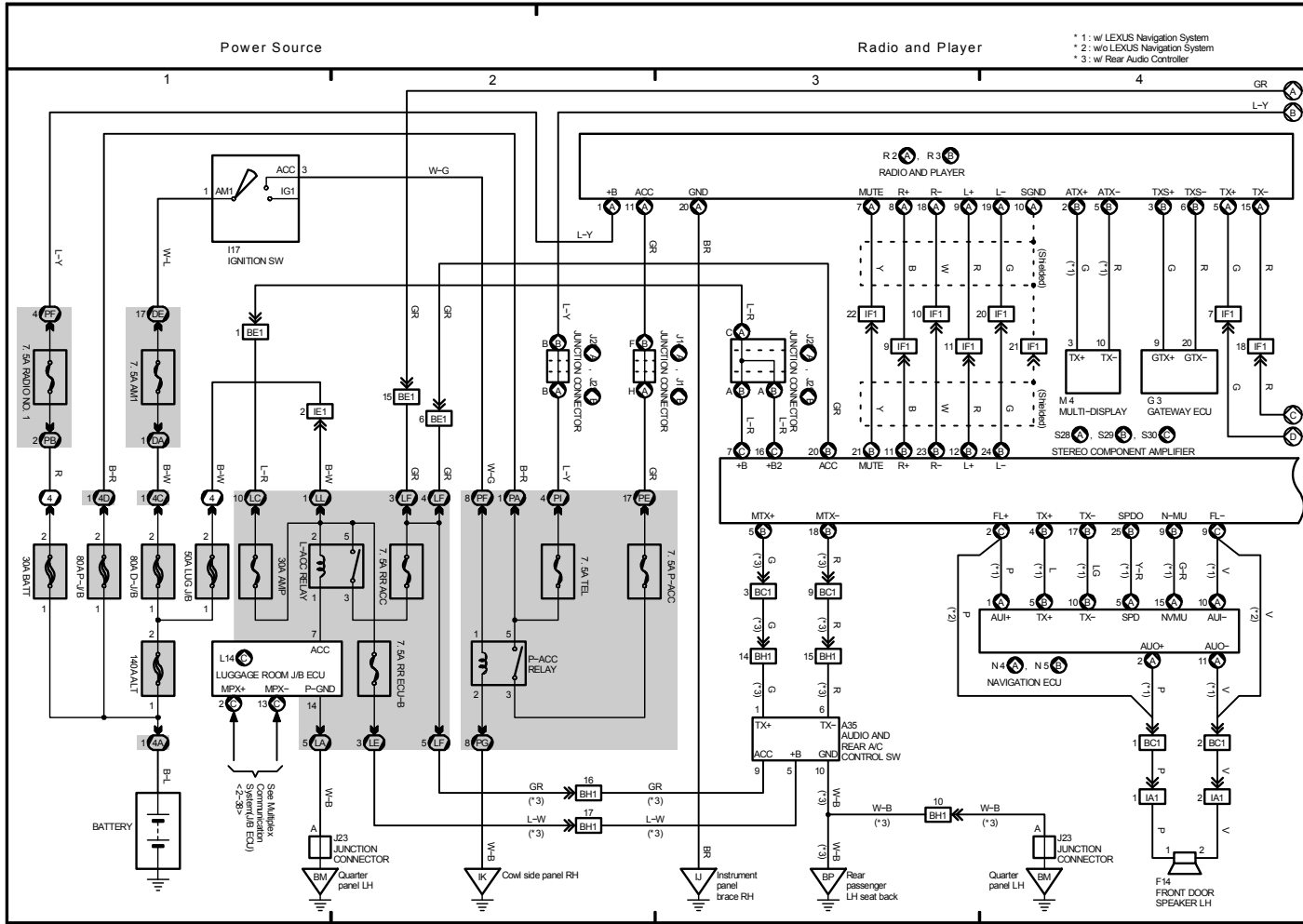

Radio and Player

* 4 : 9 Speaker
 * 5 : 7 Speaker

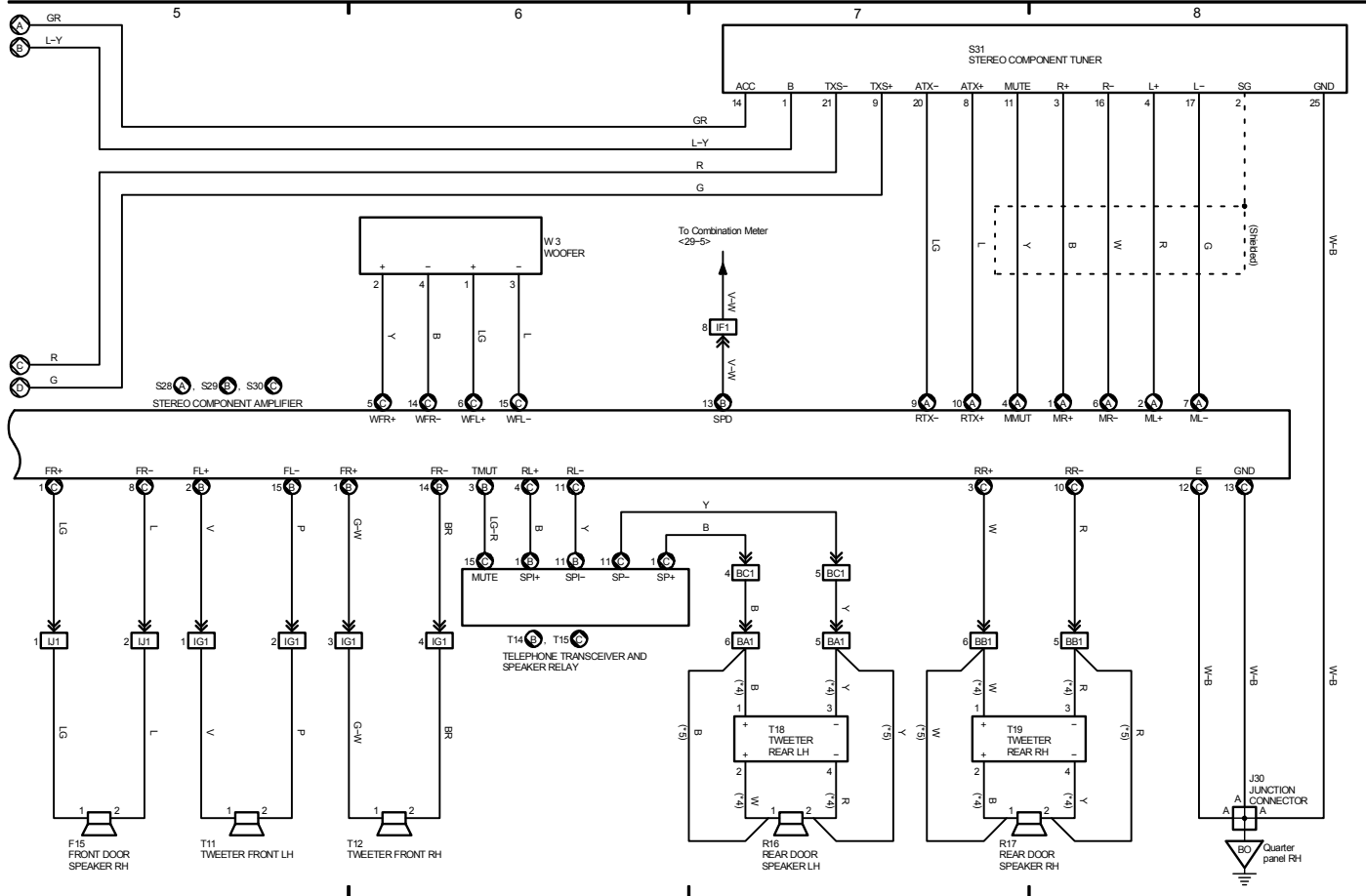

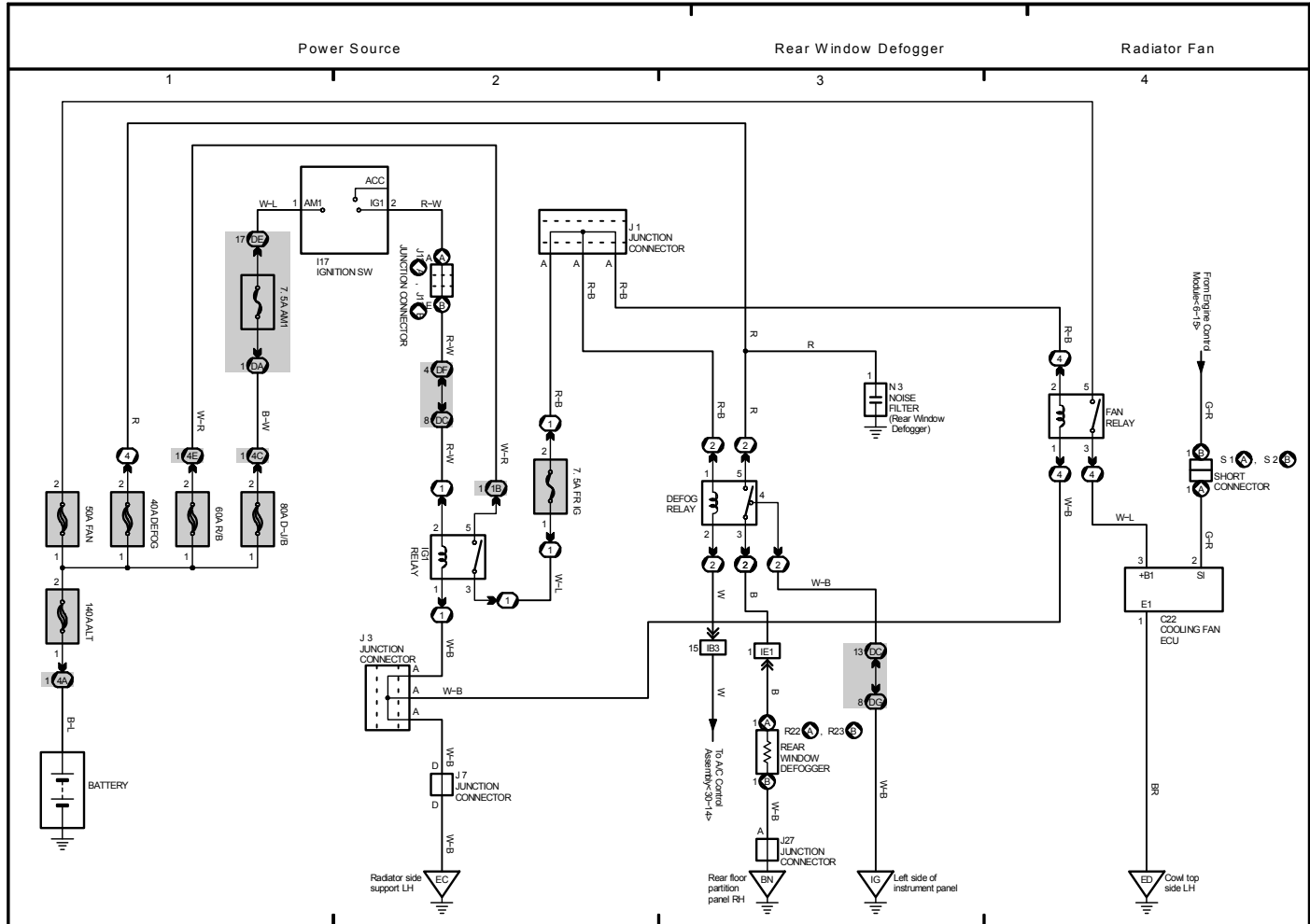

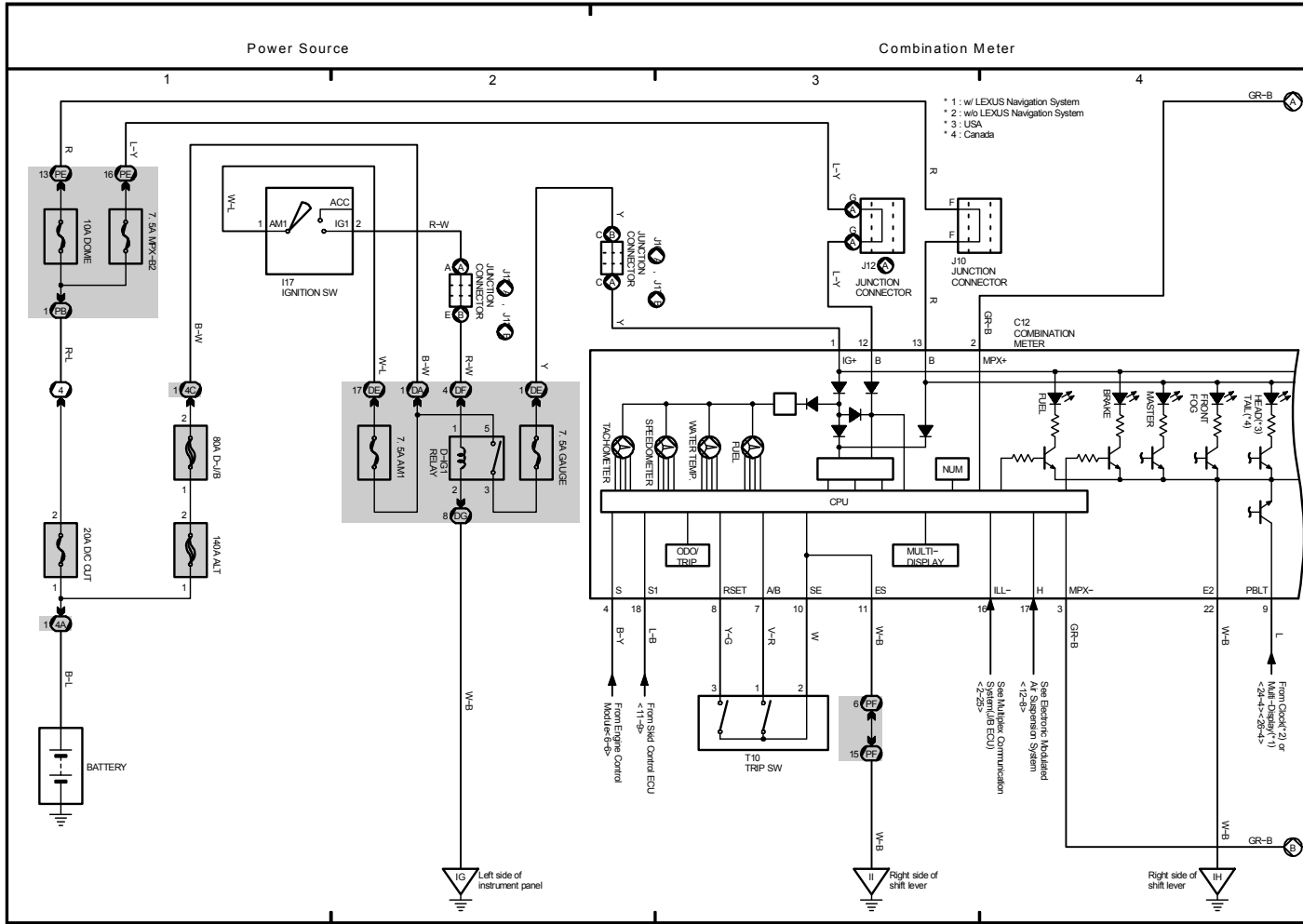

Combination Meter

* 5 : Malfunction Indicator Lamp

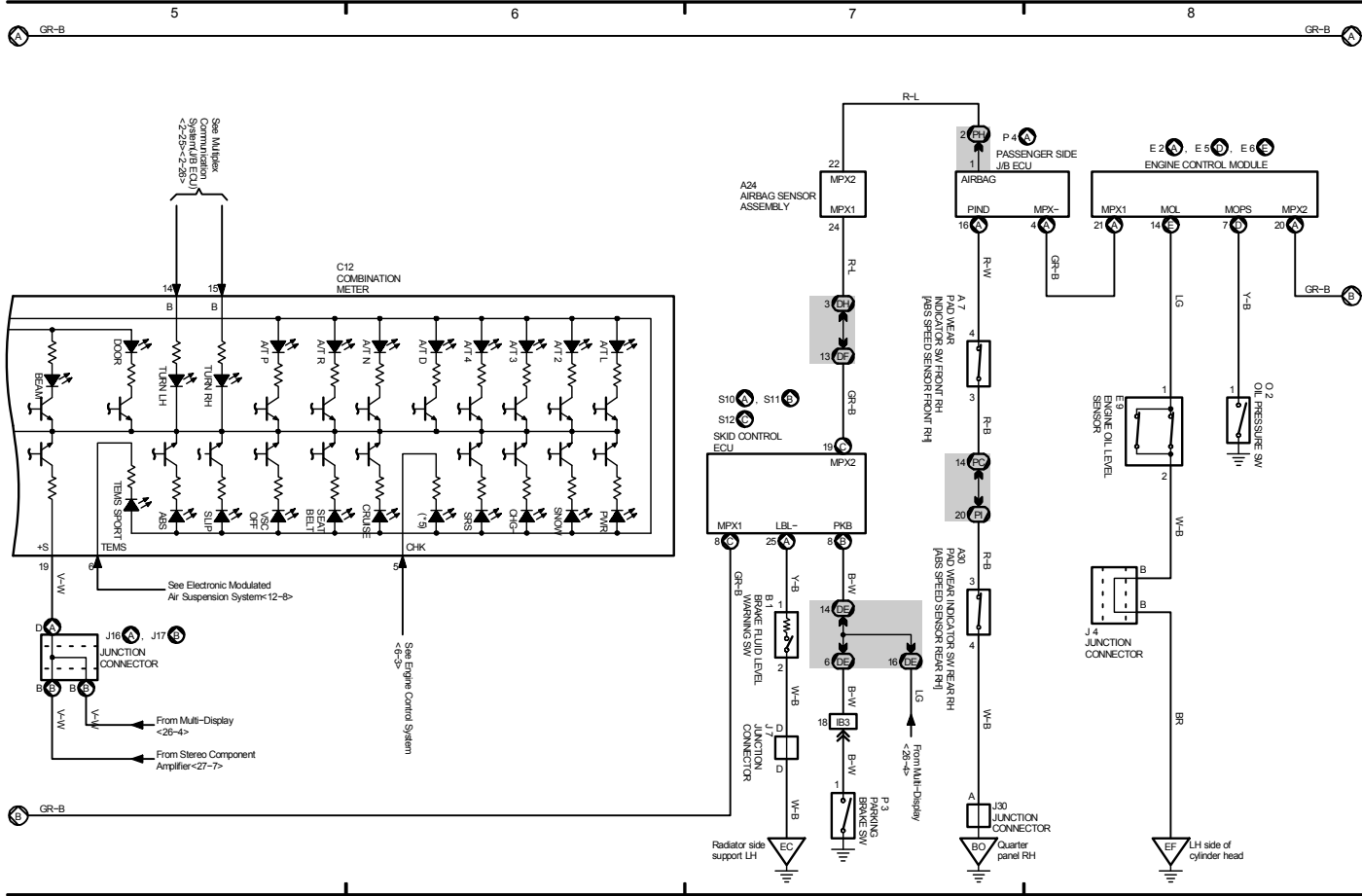

Combination Meter

- * 1 : w/ LEXUS Navigation System
- * 2 : w/o LEXUS Navigation System
- * 6 : w/ Compass

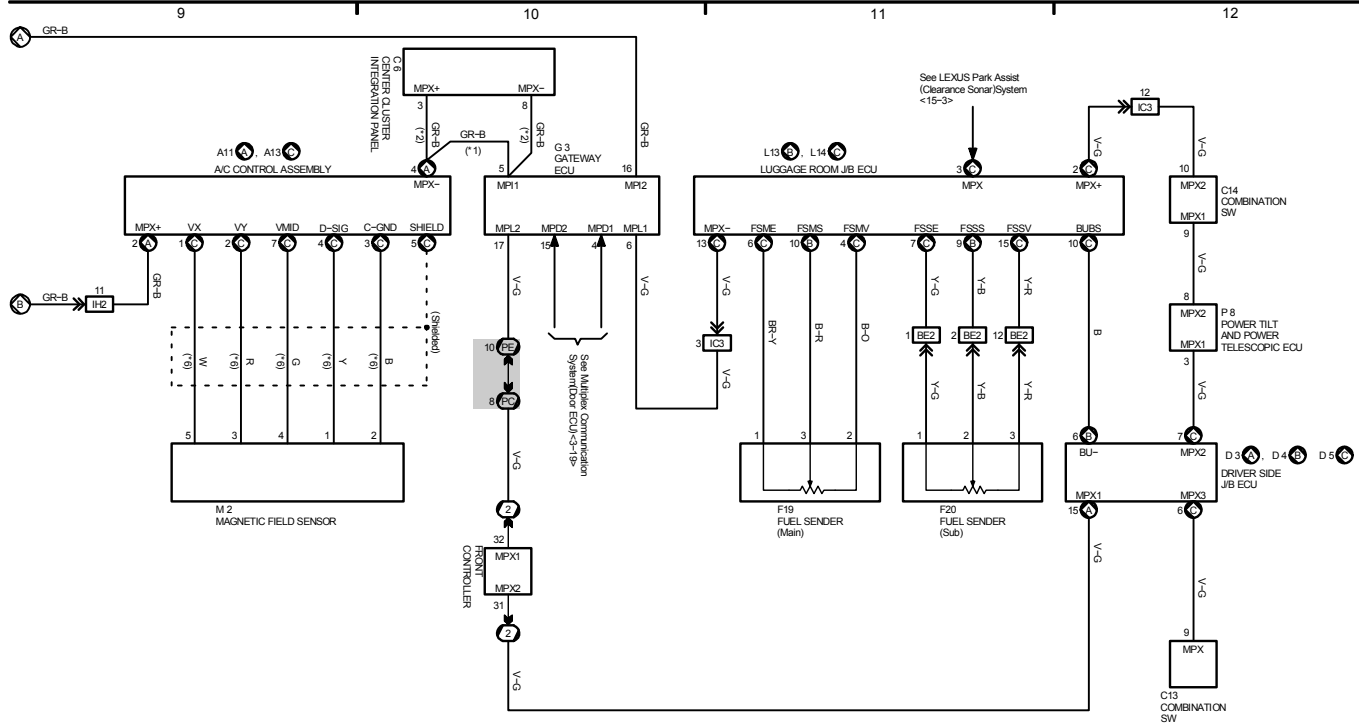

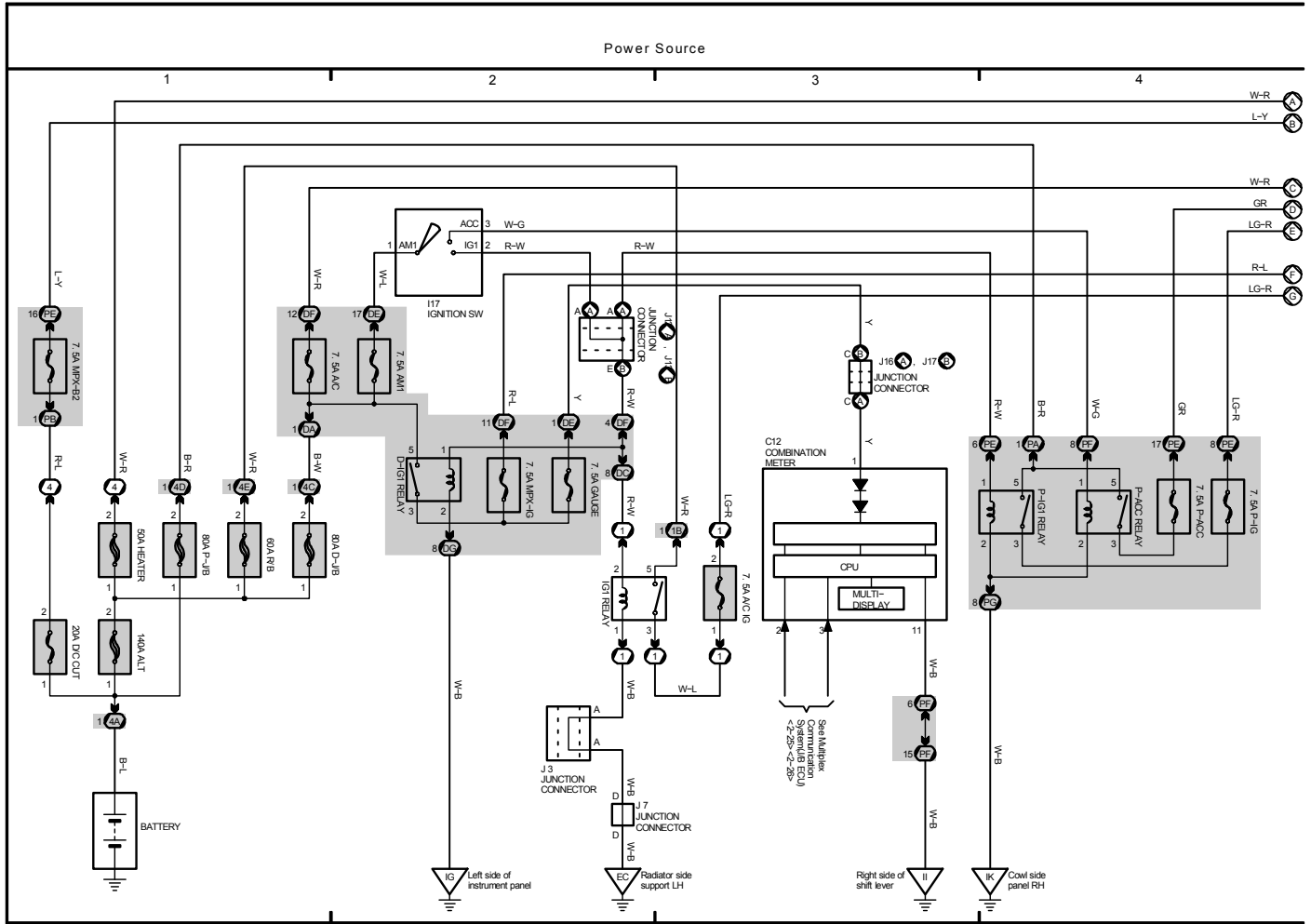

Automatic Air Conditioning (Front)

* 1 : w/ LEXUS Navigation System
 * 2 : w/o LEXUS Navigation System

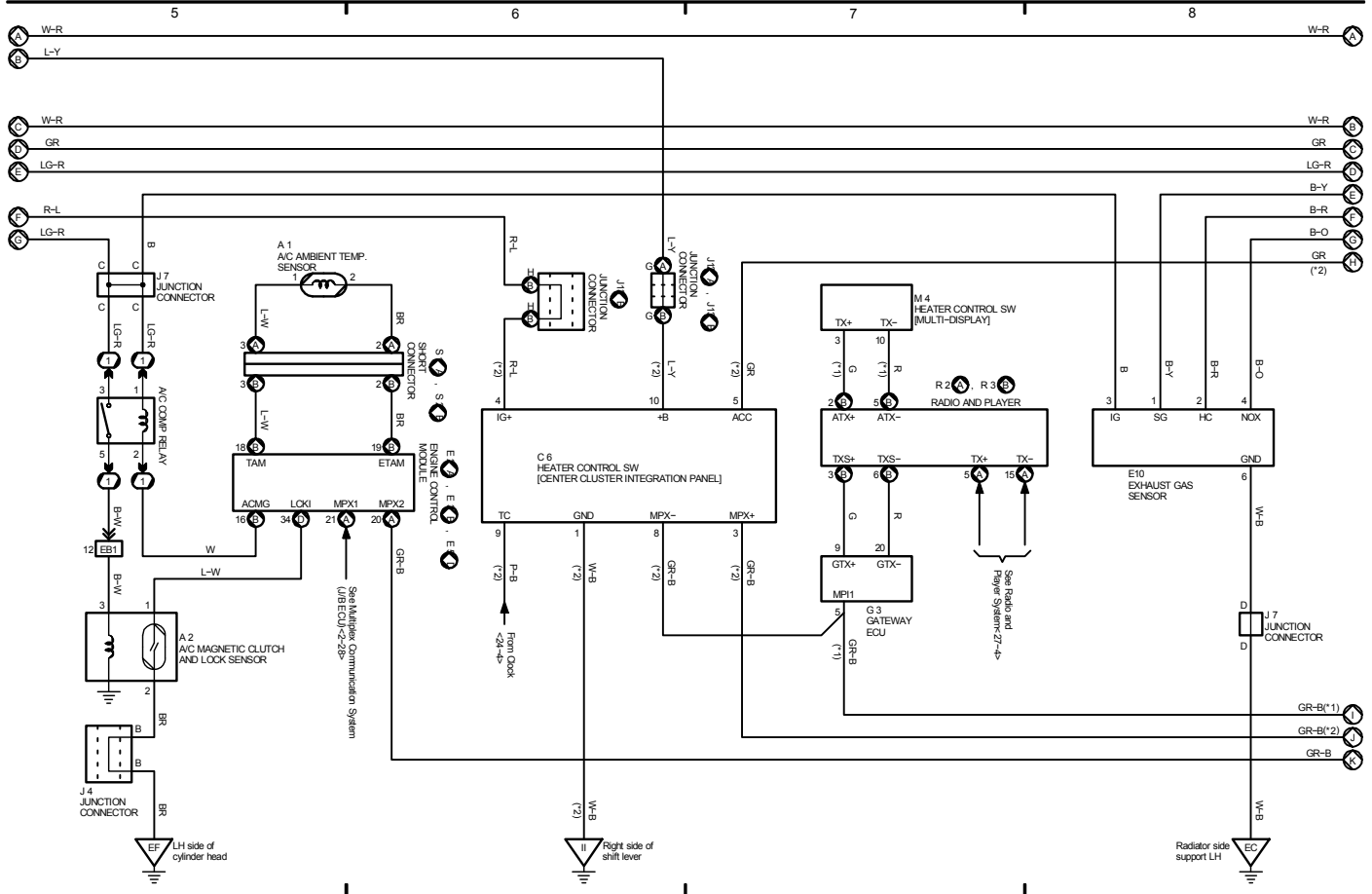

Automatic Air Conditioning (Front)

* 2 : w/o LEXUS Navigation System
 * 3 : w/ Compass

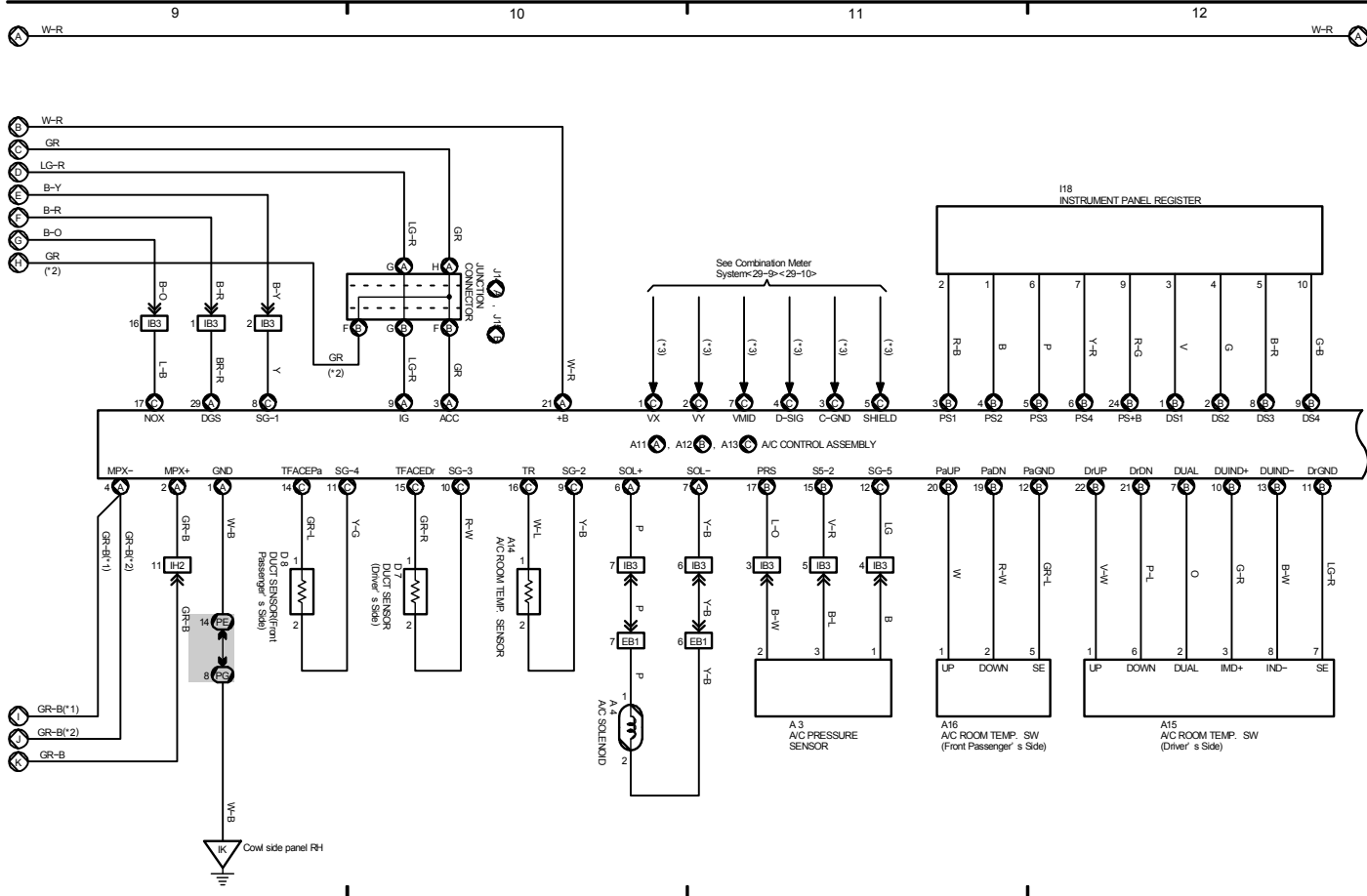

Automatic Air Conditioning (Front)

* 2 : w/o LEXUS Navigation System

