

INSPECTION

1. INSPECT MIRROR SWITCH CONTINUITY

Switch position	Tester connection	Resistance (Ω)
LEFT	8 – 9	100
RIGHT	8 – 9	0
Illumination	5 – 6	Continuity

If continuity is not as specified, replace the switch.

2. INSPECT MIRROR SWITCH RESISTANCE

Measure resistance between terminals 7 and 9 at each switch position, as shown in the chart.

Switch position	Resistance (Ω)
UP	Approx. 100
RIGHT	250
DOWN	470
LEFT	800

If resistance is not as specified, replace the switch.

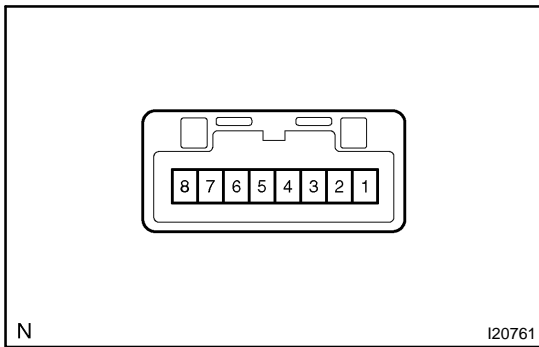

3. INSPECT RETRACT SWITCH CONTINUITY

Switch position	Tester connection	Specified condition
RETURN	–	No continuity
RETRACT	1 – 2	Continuity

If continuity is not as specified, replace the switch.

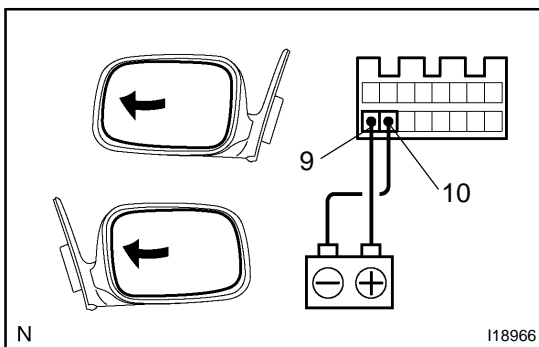

4. INSPECT MIRROR MOTOR OPERATION

- (a) Connect the positive (+) lead from the battery to terminal 9 and the negative (–) lead to terminal 11, and check that the mirror turns to the left side.

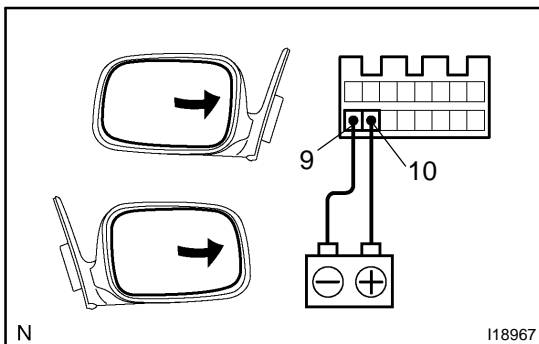

- (b) Reverse the polarity, and check that the mirror turns to the right side.

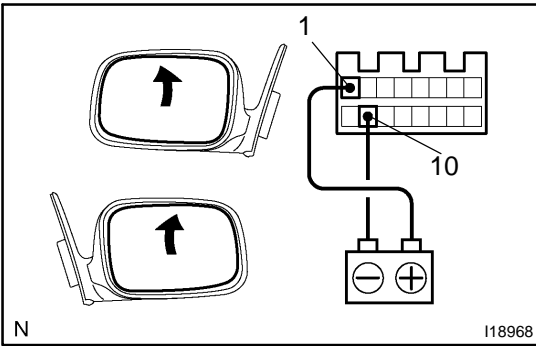

(c) Connect the positive (+) lead from the battery to terminal 1 and the negative (-) lead to terminal 10, and check that the mirror turns upward.

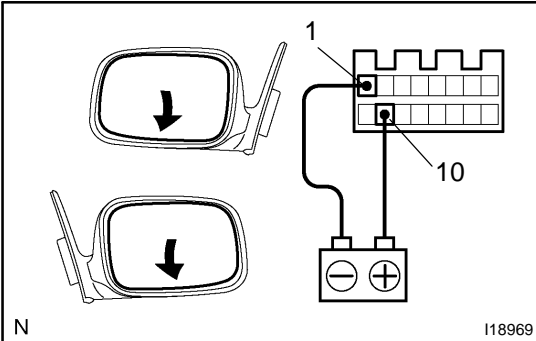

(d) Reverse the polarity, and check that the mirror turns downward.
If operation is not as specified, replace the mirror assembly.

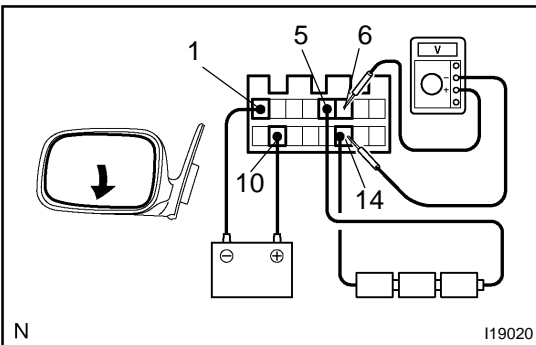

**5. w/ Driving position memory only:
INSPECT MIRROR POSITION SENSORS OPERATION**

HINT:

Strip off the vinyl tape of the connector and remove terminals 1, 5, 6, 9, 10, 13 and 14 from the connector housing.

- (a) Connect a series of three 1.5 V dry cell batteries.
- (b) Connect the positive (+) lead from the dry cell batteries to terminal 5 and the negative (-) lead to terminal 14.
- (c) Connect the positive (+) lead from the voltmeter to terminal 6 and the negative (-) lead to terminal 14.
- (d) Apply battery positive voltage to terminals 1 and 10, then check that the voltage gradually changes according to the table below while the mirror moves between the uppermost position and lowermost position.

Mirror position	Lowermost	Mirror position	Uppermost
Voltage	2.8 – 5.0	Changes gradually	0 – 1.0

If voltage value is not as specified, replace the motor assembly.

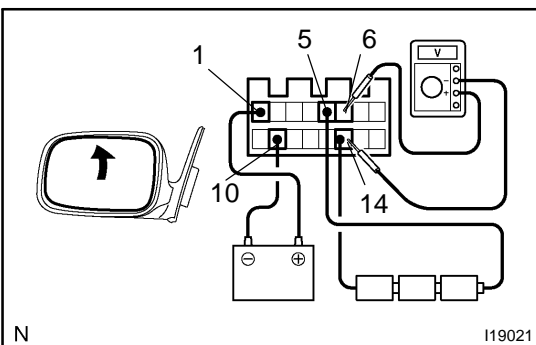

- (e) Disconnect the 4 leads of the battery and voltmeter.
- (f) Connect the positive (+) lead from the voltmeter to terminal 13 and negative (-) lead to terminal 14.

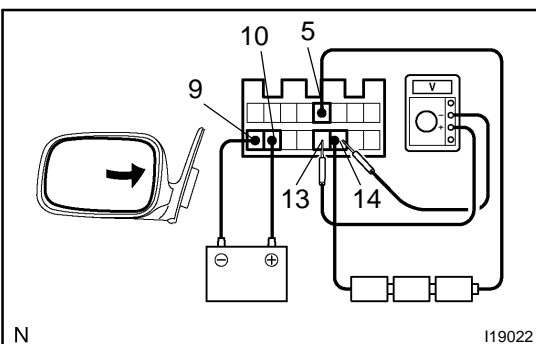

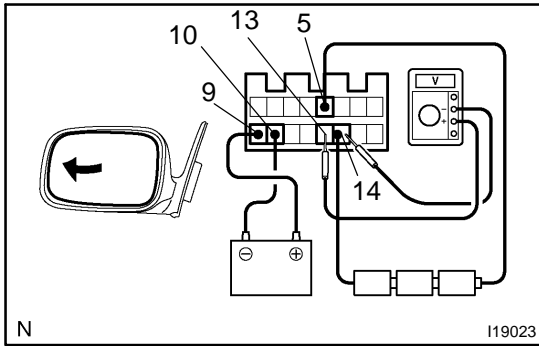

(g) Apply battery positive voltage to terminals 9 and 10, then the table below while the mirror moves between the left-most position and right-most position.

Mirror position	Lowermost	Mirror position	Uppermost
Voltage LEFT	2.8 – 5.0	Changes gradually	0 – 1.0
Voltage RIGHT	0 – 1.0	Changes gradually	2.8 – 5.0

If continuity is not as specified, replace the switch.

6. INSPECT MIRROR POSITION SENSOR CIRCUIT

Driver side: (See page [DI-1275](#))

Passenger side: (See page [DI-1336](#))

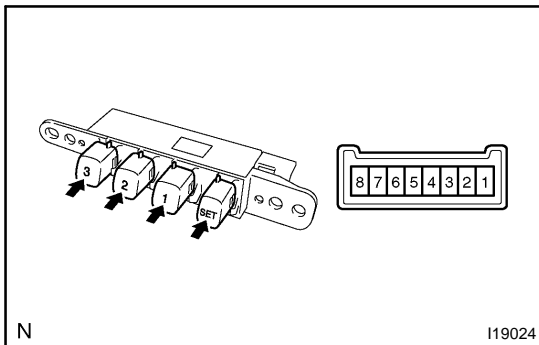

7. INSPECT DRIVING POSITION MEMORY AND RETURN SWITCH CONTINUITY

Switch position	Tester connection	Specified condition
SET switch ON	2 – 6	Continuity
Return switch1 ON	3 – 6	Continuity
Return switch2 ON	4 – 6	Continuity
Return switch3 ON	5 – 6	Continuity

If continuity is not as specified, replace the switch.

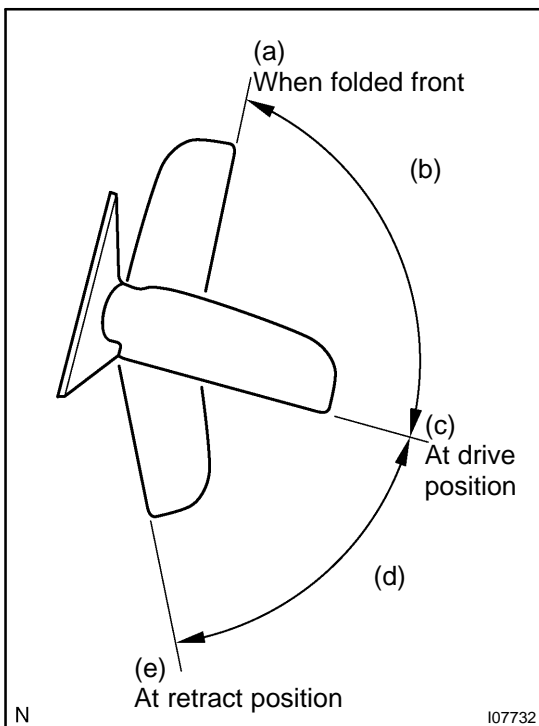

8. INSPECT ELECTRICAL RETRACT MOTOR OPERATION

(a) When folded front position:

- (1) Connect the positive (+) lead from the battery to terminal 3 and negative (-) lead to terminal 11, check that the mirror operates at retract position.
- (2) Reverse the polarity, check that the mirror operate.

If operation is not as specified, replace the mirror assembly.

(b) Between folded front position and driving position:

- (1) Connect the positive (+) lead from the battery to terminal 3 and negative (-) lead to terminal 11, check that the mirror operates at retract position.
- (2) Reverse the polarity, check that the mirror operate at folded front position.

If operation is not as specified, replace the mirror assembly.

(c) When driving position:

- (1) Connect the positive (+) lead from the battery to terminal 3 and negative (-) lead to terminal 11, check that the mirror operates at retract position.

- (2) Reverse the polarity, check that the mirror does not operate.

If operation is not as specified, replace the mirror assembly.

(d) Between driving position and retract position:

- (1) Connect the positive (+) lead from the battery to terminal 3 and negative (-) lead to terminal 11, check that the mirror operates at retract position.
- (2) Reverse the polarity, check that the mirror operate at return position (Stopping at driving position).

If operation is not as specified, replace the mirror assembly.

(e) When retract position:

- (1) Connect the positive (+) lead from the battery to terminal 3 and negative (-) lead to terminal 11, check that the mirror does not operates.
- (2) Reverse the polarity, check that the mirror operate at return position (Stopping at driving position).

If operation is not as specified, replace the mirror assembly.