

PARKING BRAKE ASSY COMPONENTS

330F9-02

Left Wheel:

Right Wheel:

Pad Wear Indicator Assembly
Bleeder Plug Cap
Clamp

Clip

Rear Disc Brake Caliper Assy LH

78 (800, 58)

Pin

Parking Brake Shoe assy No.1

Adjuster

75 (765, 55)

Shoe Hold-down Spring

Cap

Shoe Adjuster

Tension Spring

Parking Brake Shoe Lever Sub-assy

Brake Shoe Return Tension Spring

Parking Brake Shoe assy No.2

Cap

Shoe Hold-down Spring

Disc

Hole Plug

N·m (kgf·cm, ft·lbf) : Specified torque

◆ Non-reusable part

⇐ High temperature grease

OVERHAUL

HINT:

- Use the same procedures for the RH side and LH side.
- The procedures listed below are for the LH side.

1. REMOVE REAR WHEEL

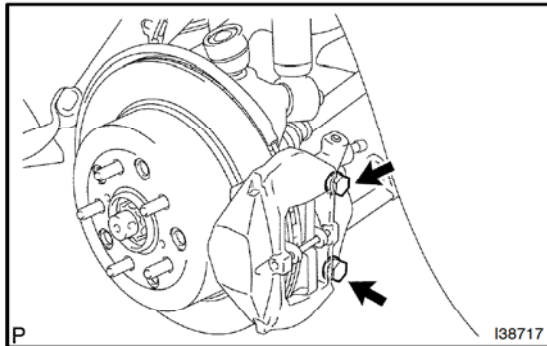

- ### 2. SEPARATE REAR DISC BRAKE CALIPER ASSY LH
- (a) Remove the 2 bolts and separate the rear disc brake caliper assy LH.

HINT:

- Do not disconnect the flexible hose from the rear disc brake caliper assy LH.
 - Do not twist or bend the rear brake caliper assy LH.
- (b) Hang the rear brake caliper assy LH with a piece of wire.

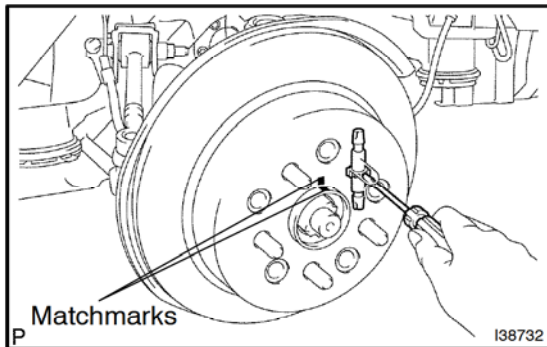

3. REMOVE REAR DISC

- (a) Release the parking brake.
- (b) Place matchmarks on the disc and rear axle hub.
- (c) Remove the disc.

HINT:

If the disc cannot be removed easily, turn the shoe adjuster until the wheel turns smoothly.

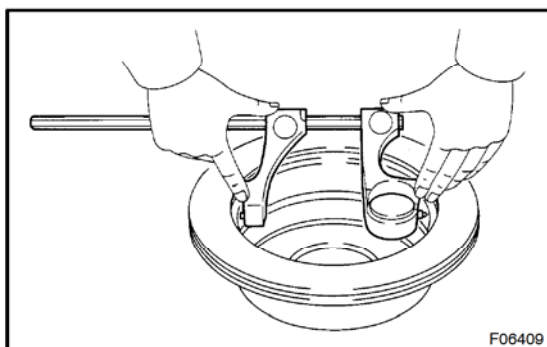

4. MEASURE BRAKE DISC INSIDE DIAMETER

Using a brake drum gauge or equivalent, measure the inside diameter of the disc.

Standard inside diameter: 190 mm (7.48 in.)

Maximum inside diameter: 191 mm (7.52 in.)

Replace the disc if the inside diameter is at the maximum value or more. Replace the disc or grind it with a lathe if the disc is scored or worn unevenly.

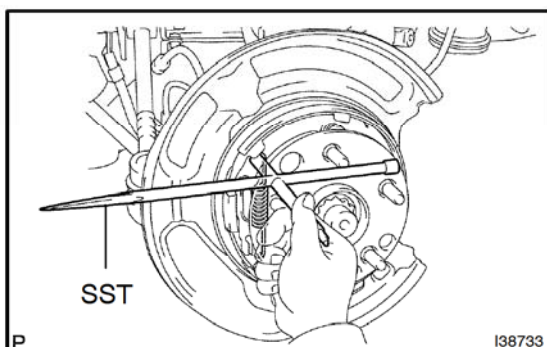

5. REMOVE PARKING BRAKE SHOE RETURN TENSION SPRING

- (a) Using SST, remove the brake shoe return tension spring.
SST 09703-30010

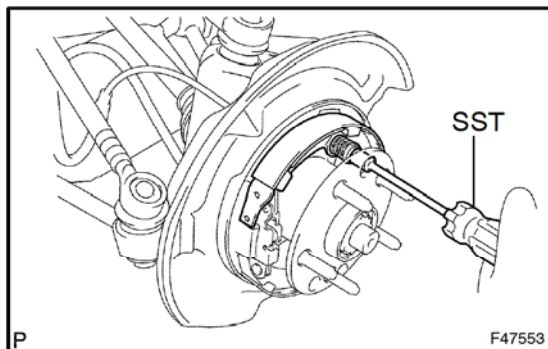

6. REMOVE PARKING BRAKE SHOE ASSY LH NO.1

- (a) Using SST, remove the cap, shoe hold-down spring and pin.
SST 09718-00010
- (b) Disconnect the tension spring from the parking brake shoe assy LH No.1.
- (c) Remove the parking brake shoe assy LH No.1 and shoe adjuster.

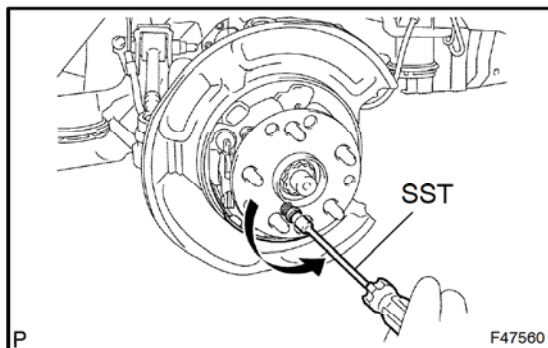

7. REMOVE PARKING BRAKE SHOE ASSY LH NO.2

- (a) Using SST, remove the cap, shoe hold-down spring and pin.
SST 09718-00010
- (b) Remove the parking brake shoe assy LH No.2.

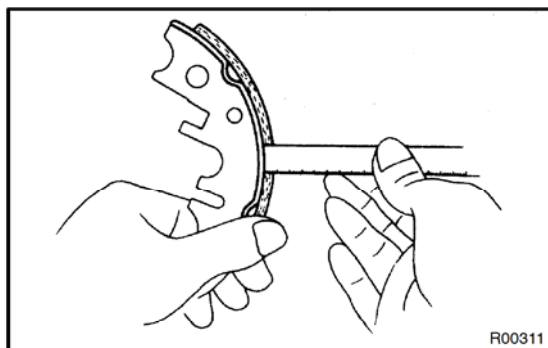

8. MEASURE PARKING BRAKE SHOE LINING THICKNESS

- (a) Using a ruler, measure the thickness of the shoe lining.
Standard thickness: 3.5 mm (0.138 in.)
Minimum thickness: 1.0 mm (0.039 in.)

If the lining thickness is at the minimum or less, or if there is severe, uneven wear, replace the brake shoe.

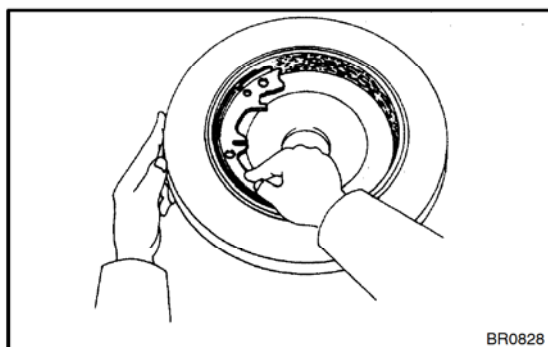

9. INSPECT BRAKE DISC AND PARKING BRAKE SHOE LINING FOR PROPER CONTACT

- (a) Apply chalk to the inside surface of the disc, then grind down the brake shoe lining to fit. If the contact between the disc and the brake shoe lining is improper, repair it using a brake shoe grinder or replace the brake shoe assembly.

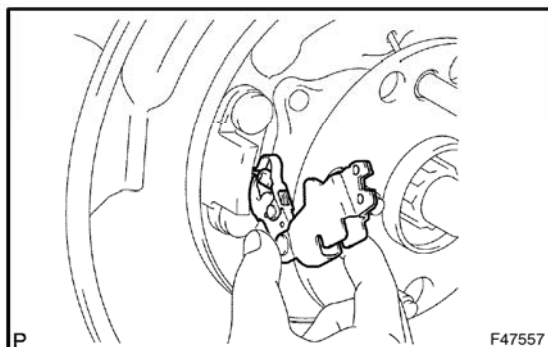

10. REMOVE PARKING BRAKE SHOE LEVER SUB-ASSY LH

- (a) Disconnect the parking brake cable assy No.3 from the parking brake shoe lever.

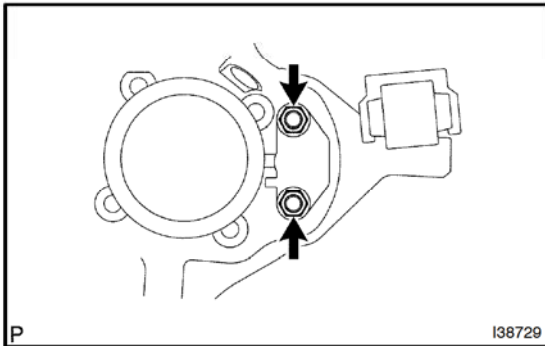
11. REMOVE PARKING BRAKE CABLE ASSY NO.3 (SEE PAGE 33-21)**12. REMOVE PARKING BRAKE CABLE NO.5 CLAMP AND ANCHOR BLOCK**

- (a) Remove the 2 nuts, parking brake cable No.5 clamp and anchor block.

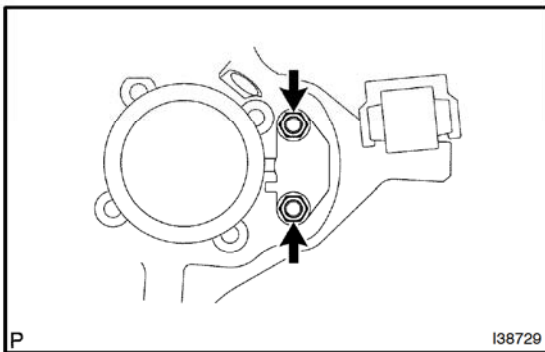
**13. REMOVE PARKING BRAKE CABLE NO.5 CLAMP AND ANCHOR BLOCK**

- (a) Install the anchor block and parking brake cable No.5 clamp with 2 nuts.

Torque: 75 N·m (765 kgf·cm, 55 in·lbf)

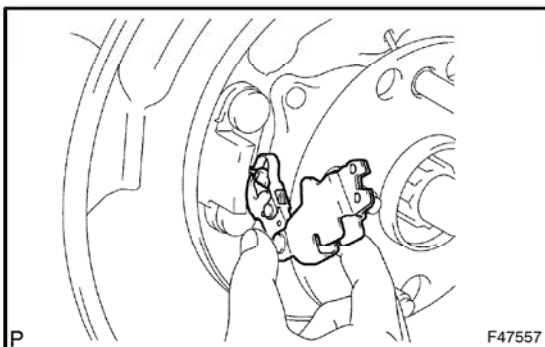
14. INSTALL PARKING BRAKE CABLE ASSY NO.3 (SEE PAGE 33-21)**15. INSTALL PARKING BRAKE SHOE LEVER SUB-ASSY LH**

- (a) Apply high temperature grease to the parking brake shoe lever LH.
- (b) Install parking brake shoe lever to the parking brake cable assy No.3.

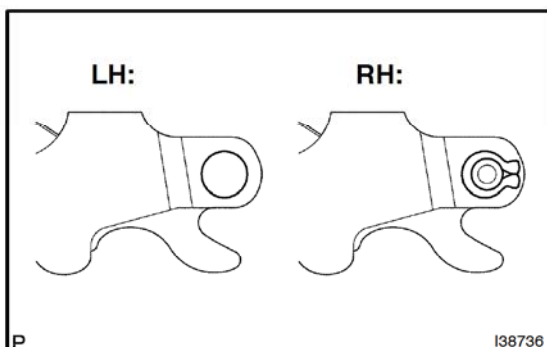
**NOTICE:**

Carefully distinguish the RH and LH on the parking brake shoe lever.

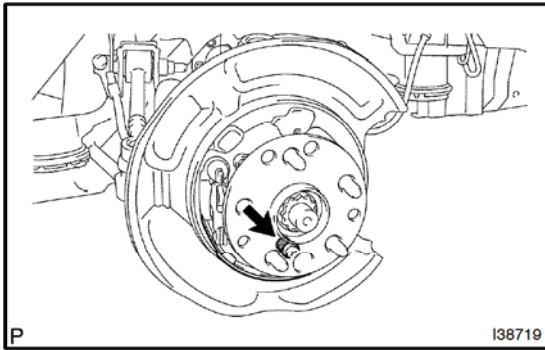
**16. INSTALL PARKING BRAKE SHOE ASSY LH NO.1**

- (a) Apply high temperature grease to the areas of the backing plate which make contact with the shoe.
- (b) Install the parking brake shoe assy LH No.1 with a pin, shoe hold-down spring and the cap.

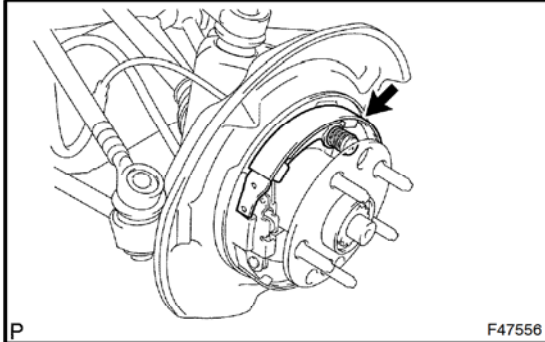
**17. INSTALL PARKING BRAKE SHOE ASSY LH NO.2**

- (a) Apply high temperature grease to the areas of the backing plate which make contact with the shoe.
- (b) Apply high temperature grease to the shoe adjuster.
- (c) Place the parking brake shoe assy LH No.2 and shoe adjuster.
- (d) Connect the tension spring.
- (e) Install the pin, shoe hold-down spring and the cap.

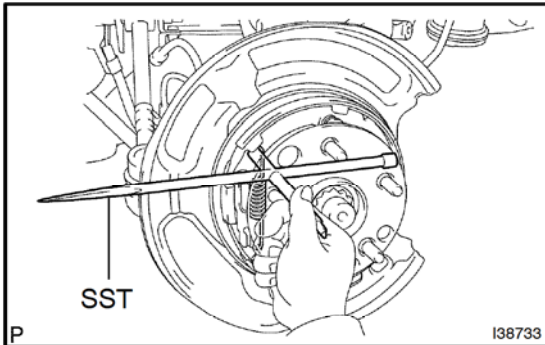
**18. INSTALL PARKING BRAKE SHOE RETURN TENSION SPRING**

- (a) Using SST, install the shoe return tension spring.
SST 09703-30010

19. CHECK PARKING BRAKE INSTALLATION

(a) Make sure that all the parts are installed properly.

If not, reinstall the parts properly.

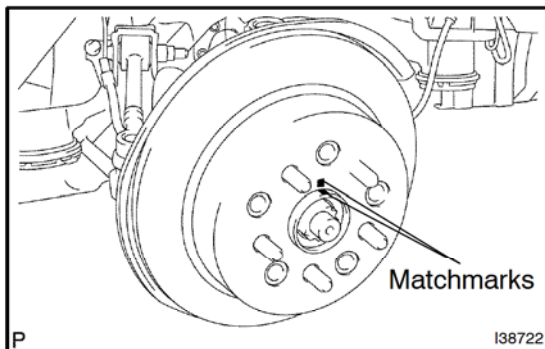
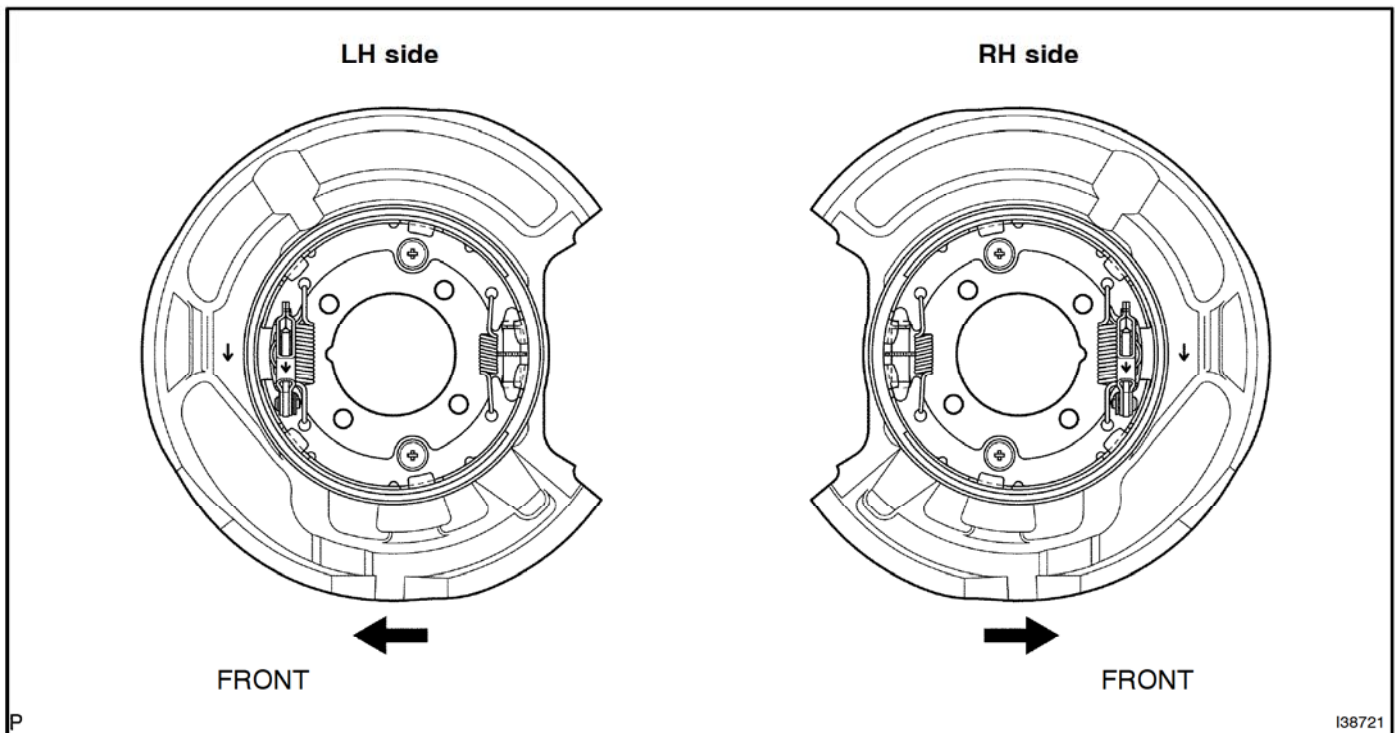
**20. INSTALL REAR DISC**

(a) Align the matchmarks on the disc and rear axle hub.

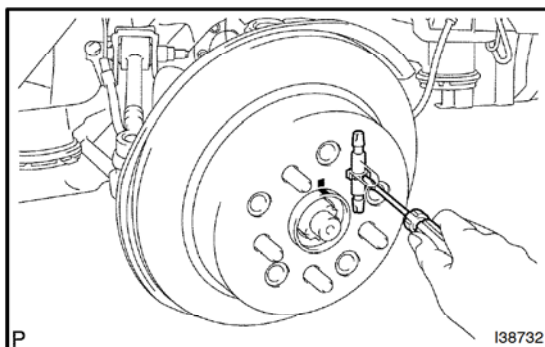
**21. ADJUST PARKING BRAKE SHOE CLEARANCE**

- (a) Remove the hole plug.
- (b) Turn the shoe adjuster and expand the shoes until the disc locks.
- (c) Return the shoe adjuster 7 notches.
- (d) Install the hole plug.

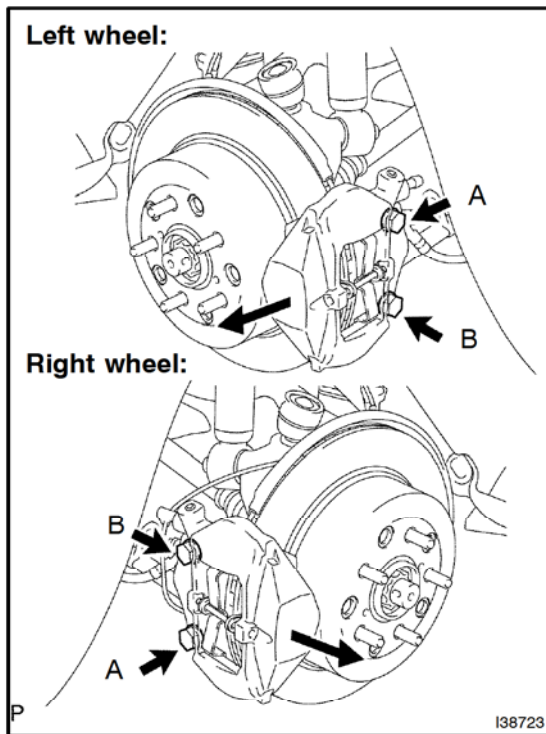
**22. INSTALL REAR DISC BRAKE CALIPER ASSY LH**

- (a) Temporarily tighten the brake caliper with the 2 new bolts.

NOTICE:

- **Brake caliper bolts can not be reused.**
- **Do not twist the brake hose.**
- **Make sure that no damage and no foreign matter is attached on the bolts.**

- (b) Pulling the brake caliper towards the outer side of the vehicle and tighten bolt A first then bolt B.

Torque: 78 N·m (800 kgf·cm , 58 ft·lbf)

NOTICE:

Do not over tighten the bolts.

23. INSTALL REAR WHEEL

Torque: 103 N·m (1,050 kgf·cm, 76 ft·lbf)

24. SETTling PARKING BRAKE SHOES AND DISC

- (a) Drive the vehicle at approximately 50 km/h (31 mph) on a safe, level and dry road.
- (b) Depress the parking brake pedal with a force of 150 N (15 kgf, 34 lbf).
- (c) Drive the vehicle for approximately 400 meters (0.25 mile) in this condition.
- (d) Repeat this procedure 2 or 3 times.

25. CHECK PARKING BRAKE PEDAL TRAVEL (SEE PAGE 33-3)**26. ADJUST PARKING BRAKE PEDAL TRAVEL (SEE PAGE 33-3)**