

DTC	B0101/14	Open in D Squib Circuit
------------	-----------------	--------------------------------

CIRCUIT DESCRIPTION

The D squib circuit consists of the airbag sensor assembly, the spiral cable and the steering wheel pad. It causes the airbag to deploy when the airbag deployment conditions are satisfied.

For details of the function of each component, see OPERATION on page RS-3.

DTC B0101/14 is recorded when an open is detected in the D squib circuit.

DTC No.	DTC Detecting Condition	Trouble Area
B0101/14	<ul style="list-style-type: none"> • Open in D squib wire harness • D squib malfunction • Spiral cable malfunction • Airbag sensor assembly malfunction 	<ul style="list-style-type: none"> • Steering wheel pad (D squib) • Spiral cable • Airbag sensor assembly • Instrument panel wire

WIRING DIAGRAM

See page DI-549.

INSPECTION PROCEDURE

1	Prepare for inspection (See step 1 on page DI-772).
----------	--

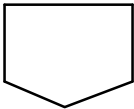

2	Check D squib circuit.
----------	-------------------------------

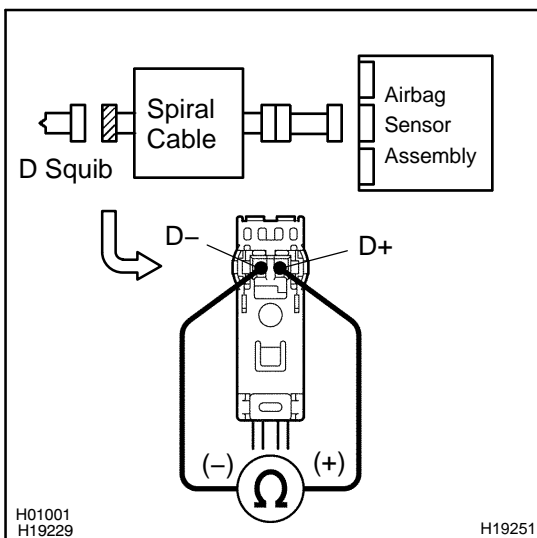

CHECK:

Measure the resistance between D+ and D- of the orange spiral cable connector on the steering wheel pad (D squib) side.

OK:

Resistance: Below 1 Ω

NG	Go to step 5.
-----------	----------------------

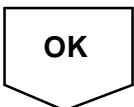

3 Check airbag sensor assembly.

PREPARATION:

- Connect the connector to the airbag sensor assembly.
- Using a service wire, connect D+ and D- of the orange spiral cable connector on the steering wheel pad (D squib) side between the airbag sensor assembly and the steering wheel pad (D squib).
- Connect the negative (-) terminal cable to the battery, and wait at least for 2 seconds.

CHECK:

- Turn the ignition switch to ON, and wait at least for 20 seconds.
- Clear the DTC stored in memory (See page [DI-532](#)).
- Turn the ignition switch to LOCK, and wait at least for 20 seconds.
- Turn the ignition switch to ON, and wait at least for 20 seconds.
- Check the DTC (See page [DI-532](#)).

OK:

DTC B0101/14 is not output.

HINT:

Codes other than code B0101/14 may be output at this time, but they are not relevant to this check.

NG

Replace airbag sensor assembly.

OK

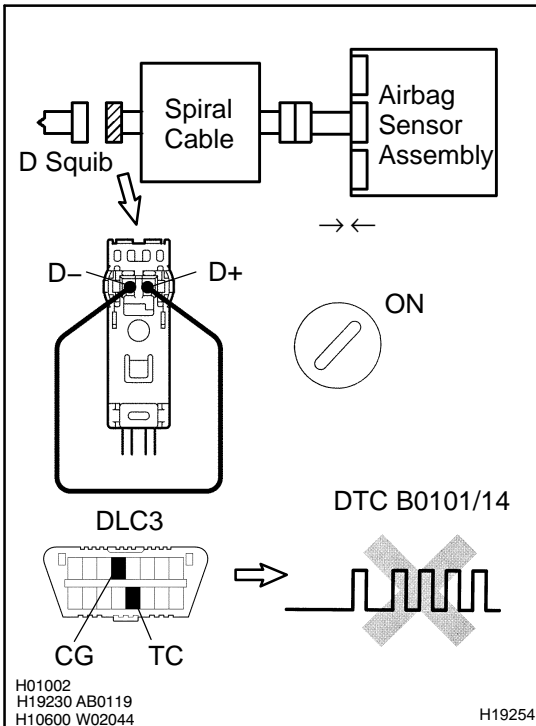

4 Check D squib.

PREPARATION:

- Turn the ignition switch to LOCK.
- Disconnect the negative (-) terminal cable from the battery, and wait at least for 90 seconds.
- Connect the steering wheel pad (D squib) connector.
- Connect the negative (-) terminal cable to the battery, and wait at least for 2 seconds.

CHECK:

- Turn the ignition switch to ON, and wait at least for 20 seconds.
- Clear the DTC stored in memory (See page [DI-532](#)).
- Turn the ignition switch to LOCK, and wait at least for 20 seconds.
- Turn the ignition switch to ON, and wait at least for 20 seconds.
- Check the DTC (See page [DI-532](#)).

OK:

DTC B0101/14 is not output.

HINT:

Codes other than code B0101/14 may be output at this time, but they are not relevant to this check.

NG

Replace steering wheel pad (D squib).

OK

From the results of the above inspection, the malfunctioning part can now be considered normal. To make sure of this, use the simulation method to check.

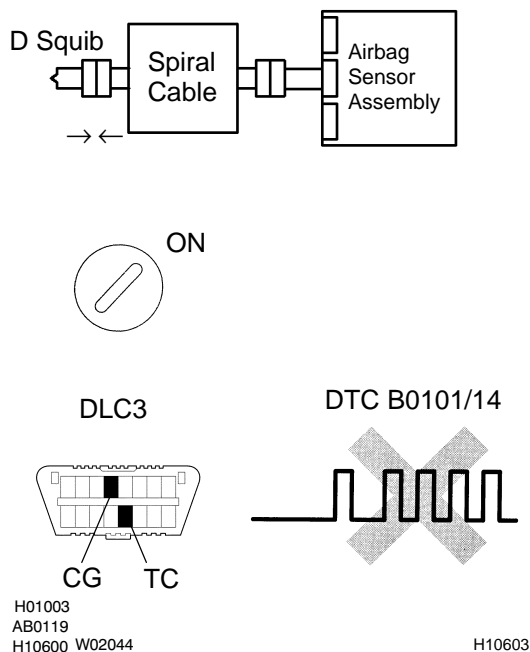

5 Check spiral cable.

PREPARATION:

Disconnect the spiral cable connector from the instrument panel wire.

CHECK:

Measure the resistance between D+ and D- of the orange spiral cable connector on the steering wheel pad (D squib) side.

OK:

Resistance: Below 1 Ω

NG

Replace spiral cable.

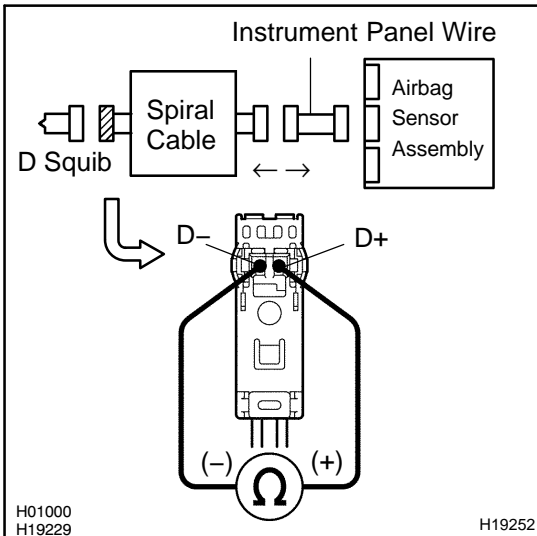

OK

6 Check instrument panel wire.

CHECK:

Measure the resistance between D+ and D- of the instrument panel wire connector on the spiral cable side.

OK:

Resistance: Below 1 Ω

NG

Replace instrument panel wire.

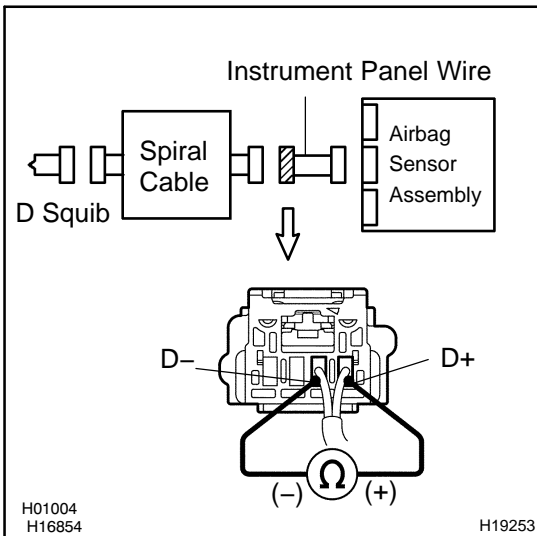

OK

From the results of the above inspection, the malfunctioning part can now be considered normal. To make sure of this, use the simulation method to check.