

REPLACEMENT

HINT:

- The installation procedures are the removal procedures in reverse order. However, only installation procedures requiring additional information are included.
 - Use the same procedures for the RH side and LH side.
 - The procedures listed below are for the RH side.
 - A bolt without a torque specification is shown in the standard bolt chart (see page 03-2).
1. REMOVE FRONT DOOR SCUFF PLATE RH (See page 76-52)
 2. REMOVE REAR DOOR SCUFF PLATE RH (See page 76-52)
 3. REMOVE FRONT DOOR OPENING TRIM WEATHERSTRIP RH (See page 76-52)
 4. REMOVE REAR DOOR OPENING TRIM WEATHERSTRIP RH (See page 76-52)

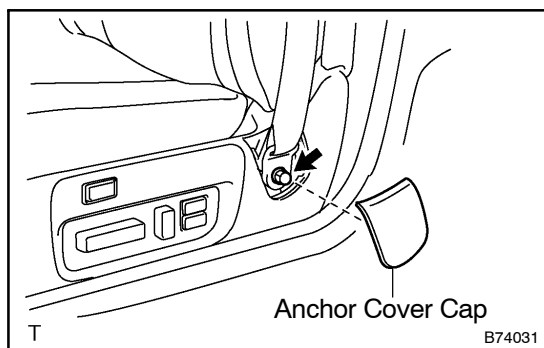

5. REMOVE SEAT BELT ANCHOR COVER CAP

- (a) Using a screwdriver, pry out the anchor cover cap.

HINT:

Tape the screwdriver tip before use.

- (b) Remove the bolt and floor anchor

6. REMOVE CENTER PILLAR GARNISH LOWER RH (See page 76-52)

7. REMOVE CENTER PILLAR GARNISH UPPER RH (See page 76-52)

8. REMOVE FRONT SEAT OUTER BELT ASSY RH

NOTICE:

- Removal of the seat belt pretensioner must be started at least 90 seconds after the ignition switch is turned OFF and the negative (-) terminal cable is disconnected from the battery.
- Carefully read the notices for the "pretensioner" in the SRS airbag system section and the front seat outer belt section (see page 60-1).

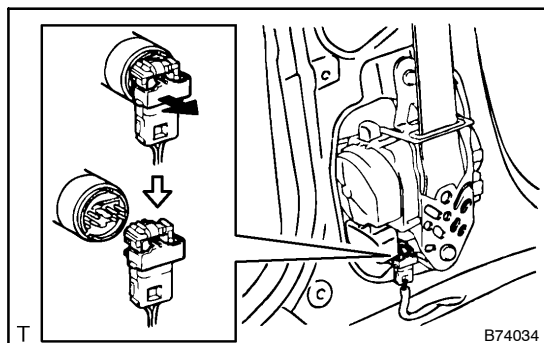

- (a) Disconnect the pretensioner connector, as shown in the illustration.
- (b) Disconnect the tension reducer connector.
- (c) w/ Pre-collision safety system:
Disconnect the tension reducer connector.
- (d) Remove the 3 bolts and outer belt.

9. REMOVE FRONT SHOULDER BELT ANCHOR ADJUSTER ASSY

- (a) Remove the 2 bolts.
- (b) Disconnect the connector and belt anchor adjuster.

10. REMOVE FRONT SEAT INNER BELT ASSY RH

- (a) Remove the front seat (see page 72-3).
- (b) Disconnect the connector.
- (c) Remove the nut and inner belt.

11. INSTALL FRONT SEAT INNER BELT ASSY RH

- (a) Install the inner belt with the nut.

Torque: 42 N·m (428 kgf·cm, 31 ft·lbf)

12. INSTALL FRONT SHOULDER BELT ANCHOR ADJUSTER ASSY

- (a) Install the belt anchor adjuster with the 2 bolts.

Torque: 42 N·m (428 kgf·cm, 31 ft·lbf)

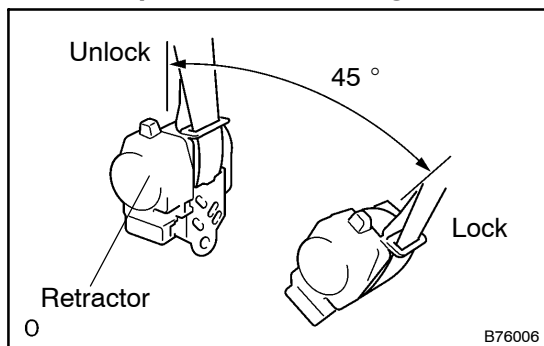
**13. INSTALL FRONT SEAT OUTER BELT ASSY RH****NOTICE:**

Do not disassemble the retractor.

- (a) Check the amount of inclination required to lock the retractor.
 - (1) When the inclination of the retractor is 15° or less, check that the belt can be pulled from the retractor. When the inclination of the retractor is over 45°, check that the belt locks.

If operation is not as specified, replace the outer belt assy.

- (b) Install the outer belt with the 2 bolts.

Torque:

7.5 N·m (76.5 kgf·cm, 66 in·lbf) for upper bolt

42 N·m (428 kgf·cm, 31 ft·lbf) for lower bolt

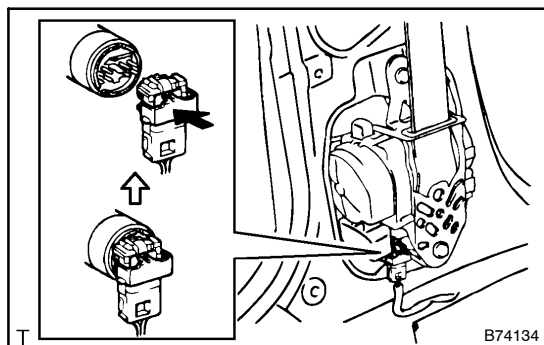

- (c) Connect the pretensioner connector, as shown in the illustration.
- (d) Connect the tension reducer connector.
- (e) w/ Pre-collision safety system:
Connect the tension reducer connector.
- (f) Install the floor anchor cover.
- (g) Install the shoulder belt anchor to the shoulder belt anchor adjuster with the bolt.
 - Torque: 42 N·m (428 kgf·cm, 31 ft·lbf)**
- (h) Install the front pillar garnish upper.
- (i) Install the center pillar garnish lower.
- (j) Install the floor anchor to the front seat with the bolt.
 - Torque: 42 N·m (428 kgf·cm, 31 ft·lbf)**
- (k) Install the front door scuff plate.
- (l) Install the rear door scuff plate.
- (m) Install the front door opening trim weatherstrip.
- (n) Install the rear door opening trim weatherstrip.

(o) Check if the ELR locks.

NOTICE:

The check should be performed with the outer belt assy installed.

- (1) With the belt installed, check that the belt locks when it is pulled out quickly.

If operation is not as specified, replace the outer belt assy.

(p) Connect the negative battery's terminal.

NOTICE:

When disconnecting the negative (-) battery terminal, initialize the following systems after the terminal is reconnected.

System Name	See Page
Front Power Seat Control System	01-20

(q) Check the SRS warning lamp (see page [05-1032](#)).