

PRE-CHECK

1. DIAGNOSIS SYSTEM

(a) Description

- When troubleshooting vehicles with OBD II, the only difference from the usual troubleshooting procedure is that you connect an OBD II scan tool complying with SAE J1987 or hand-held tester to the vehicle, and read off various data output from the vehicle's ECM.
- OBD II regulations require that the vehicle's on-board computer lights up the Malfunction Indicator Lamp (MIL) on the instrument panel when the computer detects a malfunction in the computer itself or in drive system components which affect vehicle emissions. In addition to the MIL lighting up when a malfunction is detected, the applicable DTCs prescribed by SAE J2012 are recorded in the ECM memory (See page [DI-15](#)).
If the malfunction not occurs in 3-trips, the MIL goes off but the DTCs remain recorded in the ECM memory.

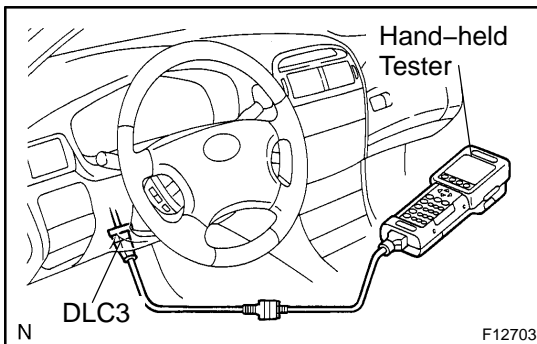

- To check the DTCs, connect an OBD II scan tool or hand-held tester to DLC3 on the vehicle. The OBD II scan tool or hand-held tester also enables you to erase the DTCs and check freeze frame data and various forms of engine data (For instruction book).
- DTCs include SAE controlled codes and Manufacturer controlled codes.
SAE controlled codes must be set as the codes prescribed by the SAE, while Manufacturer controlled codes can be set freely by the manufacturer within the prescribed limits (See DTC chart on page [DI-15](#)).

- The diagnosis system operates in normal mode during normal vehicle use, and also has a check mode for technicians to simulate malfunction symptoms and perform troubleshooting. Most DTCs use 2-trip detection logic (*) to prevent erroneous detection. By switching the ECM to check mode when troubleshooting, the technician can cause the MIL to light up for a malfunction that is only detected once or momentarily (Hand-held tester) (See page [DI-237](#)).
- *2-trip detection logic:
When a logic malfunction is first detected, the malfunction is temporarily stored in the ECM memory. If the same malfunction is detected again during the 2nd test drive, this 2nd detection causes the MIL to light up. The 2-trip repeats the same mode 2nd time (However, the IG switch must be turned OFF between the 1st trip and 2nd trip.).

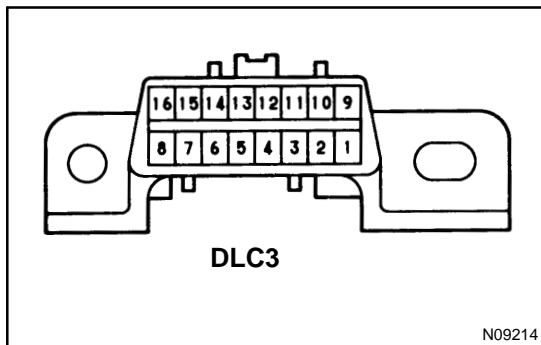

- (b) Inspect the DLC3.
The vehicle's ECM uses the ISO 9141-2 communication protocol. The terminal arrangement of DLC3 complies with SAE J1962 and matches the ISO 9141-2 format.

Terminal No.	Connection / Voltage or Resistance	Condition
7	Bus ⊕ Line / Pulse generation	During communication
4	Chassis Ground ↔ Body / 1 Ω or less	Always
5	Signal Ground ↔ Body / 1 Ω or less	Always
16	Battery Positive ↔ Body / 9 – 14 V	Always

HINT:

If your display shows "UNABLE TO CONNECT TO VEHICLE" when you have connected the cable of OBD II scan tool or hand-held tester to DLC3, turned the ignition switch ON and operated the scan tool, there is a problem on the vehicle side or tool side.

- If communication is normal when the tool is connected to another vehicle, inspect DLC3 on the original vehicle.
- If communication is still not possible when the tool is connected to another vehicle, the problem is probably in the tool itself, so consult the Service Department listed in the tool's instruction manual.

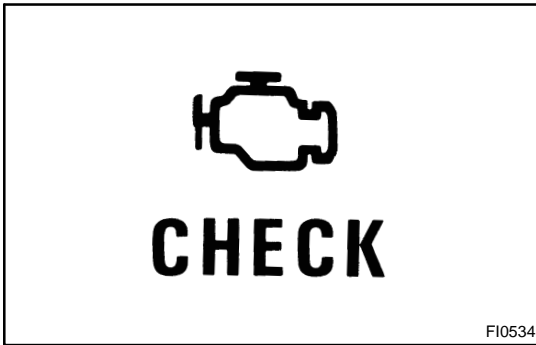

2. INSPECT DIAGNOSIS (NORMAL MODE)

- (a) Check the MIL.
- (1) The MIL comes on when the ignition switch is turned ON and the engine is not running.

HINT:

If the MIL does not light up, troubleshoot the combination meter (See page [BE-11](#)).

- (2) When the engine is started, the MIL should go off. If the lamp remains on, the diagnosis system has detected a malfunction or abnormality in the system.

- (b) Check the DTC.

NOTICE:

Hand-held tester only: When the diagnostic system is switched from normal mode to check mode, it erases all DTCs and freeze frame data recorded in normal mode. So before switching modes, always check the DTCs and freeze frame data, and note them down.

- (1) Prepare an OBD II scan tool (complying with SAE J1978) or hand-held tester.
- (2) Connect the OBD II scan tool or hand-held tester to DLC3 at the lower of the instrument panel.
- (3) Turn the ignition switch ON and turn the OBD II scan tool or hand-held tester switch ON.
- (4) Use the OBD II scan tool or hand-held tester to check the DTCs and freeze frame data and note them down (For operating instructions, see the OBD II scan tool's instruction book).
- (5) See page [DI-248](#) to confirm the details of the DTCs.

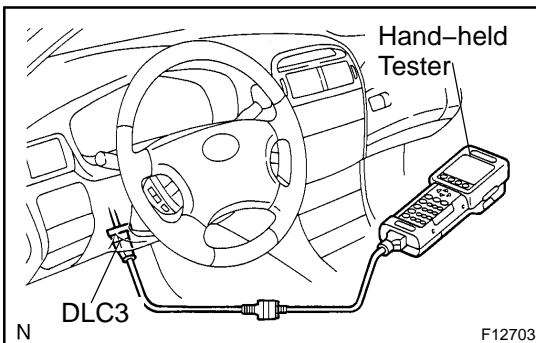

NOTICE:

When simulating symptoms with an OBD II scan tool (excluding hand-held tester) to check the DTCs, use normal mode. For codes on the DTCs chart subject to "2-trip detection logic", turn the ignition switch OFF after the symptoms have been simulated the 1st time. Then repeat the simulation process again. When the program has DTCs, the DTCs are recorded in the ECM.

3. INSPECT DIAGNOSIS (CHECK MODE)

HINT:

Hand-held tester only: Compared to the normal mode, the check mode has high sensing ability to detect malfunctions. Furthermore, the same diagnostic items which are detected in Normal mode can also be detected in Check mode.

(a) Check the DTC.

- (1) Check the initial conditions.
 - Battery positive voltage 11 V or more
 - Throttle valve fully closed
 - Transmission in P position
 - Air conditioning switched OFF
- (2) Turn the ignition switch OFF.
- (3) Prepare a hand-held tester.

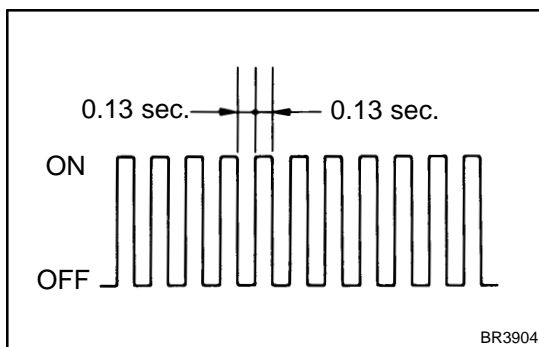
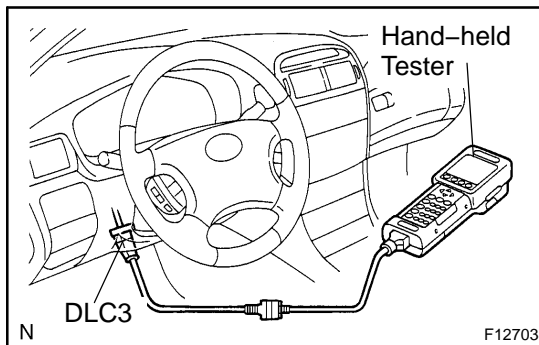

- (4) Connect the hand-held tester to DLC3 at the lower side of the instrument panel.
- (5) Turn the ignition switch ON and switch the hand-held tester ON.
- (6) Switch the hand-held tester from Normal mode to Check mode (Check that the MIL flashes).
- (7) Start the engine (MIL goes out after the engine starts).
- (8) Simulate the conditions of the malfunction described by the customer.

NOTICE:

Leave the ignition switch ON until you have checked the DTCs, etc.

- (9) After simulating the malfunction conditions, use the hand-held tester diagnosis selector to check the DTCs and freeze frame data, etc.

HINT:

Be sure not to turn the ignition switch OFF, as turning it off switches the diagnosis system from Check mode to Normal mode, which erases all DTCs, etc.

- (10) After checking the DTC, inspect the applicable circuit.

(b) Clear the DTC.

The following operation will erase the DTC and freeze frame data. Operate an OBD II scan tool (complying with SAE J1978) or hand-held tester to erase the codes (See the OBD II scan tool's instruction book for operating instructions.).

4. ROAD TEST**NOTICE:**

Perform the test at normal operating ATF temperature 50 – 80 °C (122 – 176 °F).

(a) D position test (NORM and PWR pattern):

Shift into the D position and fully depress the accelerator pedal and check the following points.

(1) Check up-shift operation.

Check that 1 → 2, 2 → 3, 3 → 4 and 4 → 5th up-shifts take place, and that the shift points conform to the automatic shift schedule (See page [SS-24](#)).

HINT:

- 5th Gear Up-shift Prohibition Control (1. Coolant temp. is 55 °C (128 °F) or less. 2. Vehicle speed is 51 km/h (32 mph) or less.)
 - 5th Gear Lock-up Prohibition Control (1. Brake pedal is depressed. 2. Coolant temp. is 60 °C (140 °F) or less.)
- (2) Check for shift shock and slip.
Check for shock and slip at the 1 → 2, 2 → 3, 3 → 4 and 4 → 5th up-shifts.
- (3) Check for abnormal noises and vibration.
Drive in the D position lock-up or 5th gear and check for abnormal noises and vibration.

HINT:

The check for the cause of abnormal noises and vibration must be done very thoroughly as it could also be due to loss of balance in the differential, torque converter clutch, etc.

(4) Check kick-down operation.

While running in the D position, 2nd, 3rd, 4th and 5th gears, check that the possible kick-down vehicle speed limits for 2 → 1, 3 → 2, 4 → 3 and 5th → 4 kick-downs conform to those indicated on the automatic shift schedule (See page [SS-24](#)).

(5) Check abnormal shock and slip at kick-down.

(6) Check the lock-up mechanism.

- Drive in D position 5th gear, at a steady speed (lock-up ON) of about 70 km/h (43 mph).
- Lightly depress the accelerator pedal and check that the engine speed does not change abruptly.

If there is a big jump in engine speed, there is no lock-up.

(b) 4 position test:

Shift into the 4 position and fully depress the accelerator pedal and check the following points.

(1) Check up-shift operation.

Check that the 1 → 2, 2 → 3 and 3 → 4 up-shift takes place and that the shift point conforms to the automatic shift schedule (See page [SS-24](#)).

HINT:

There is no 5th up-shift in the 4 position.

(2) Check engine braking.

While driving in the 4 position and 4th gear, release the accelerator pedal and check the engine braking effect.

(3) Check for abnormal noises during acceleration and deceleration, and for shock at up-shift and down-shift.

- (c) 3 position test:
Shift into the 3 position and fully depress the accelerator pedal and check the following points.
- (1) Check up–shift operation.
Check that the 1 → 2 and 2 → 3 up–shift takes place and that the shift point conforms to the automatic shift schedule (See page [SS-24](#)).
 - (2) Check engine braking.
While running in the 3 position and 3rd gear, release the accelerator pedal and check the engine braking effect.
 - (3) Check for abnormal noises during acceleration and deceleration, and for shock at up–shift and down–shift.
- (d) 2 position test:
Shift into the 2 position and fully depress the accelerator pedal and check the following points.
- (1) Check up–shift operation.
Check that the 1 → 2 up–shift takes place and that the shift point conforms to the automatic shift schedule (See page [SS-24](#)).
 - (2) Check engine braking.
While running in the 2 position and 2nd gear, release the accelerator pedal and check the engine braking effect.
 - (3) Check for abnormal noises during acceleration and deceleration, and for shock at up–shift and down–shift.
- (e) L position test:
Shift into the L position and fully depress the accelerator pedal and check the following points.
- (1) Check no up–shift.
While running in the L position, check that there is no up–shift to 2nd gear.
 - (2) Check engine braking.
While running in the L position, release the accelerator pedal and check the engine braking effect.
 - (3) Check for abnormal noises during acceleration and deceleration.
- (f) R position test:
Shift into the R position and fully depress the accelerator pedal and check for slipping.

CAUTION:

Before conducting this test ensure that the test area is free from people and obstruction.

- (g) P position test:
Stop the vehicle on a grade (more than 5°) and after shifting into the P position, release the parking brake. Then, check that the parking lock pawl holds the vehicle in place.

5. ACTIVE TEST

You are able to set the A/T gear position as you like by operating each solenoid valve forcibly using OBD II scan tool or hand–held tester.

However, the condition that you can set the gear position differs depending on the setting gear position, so perform the ACTIVE TEST following conditions in the table below.

No.	Indication Gear Condition	Starting Condition	Canceling Condition
1	1st, 2nd	Vehicle speed: 0 km/h (0 mph)	Vehicle speed: 0 km/h (0 mph)
2	3rd	Vehicle speed: 0 km/h (0 mph) or vehicle running at 4th or 5th gear	Vehicle speed: more than 50km/h (31 mph)
3	4th	<ul style="list-style-type: none"> • Vehicle running at 3rd or 5th gear • Vehicle speed: less than 50 km/h (31 mph) 	Vehicle speed: more than 50 km/h (31 mph)

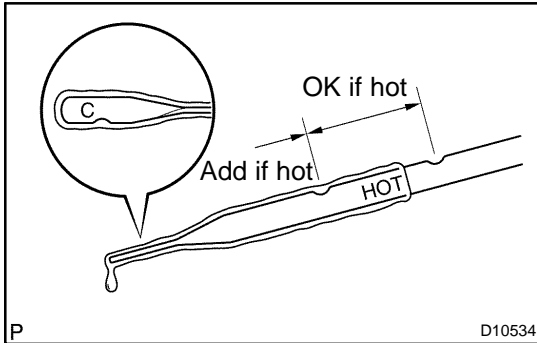
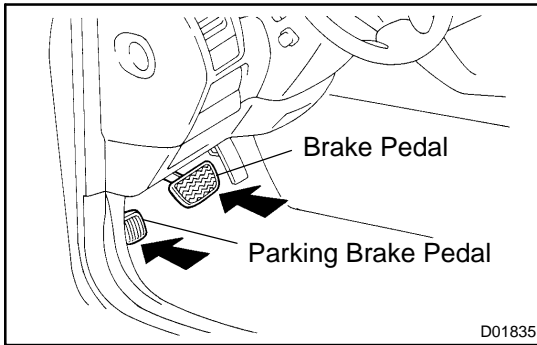

6. BASIC INSPECTION

(a) Check the fluid level.

HINT:

- Drive the vehicle so that the engine and transmission are at normal operating temperature.

Fluid temp.: 70 – 80 °C (158 – 176 °F)

- Only use the COOL range on the dipstick as a rough reference when the fluid is replaced or the engine does not run.

- (1) Park the vehicle on a level surface and set the parking brake.
- (2) With the engine idling and the brake pedal depressed, shift the shift lever into all positions from P to L position and return to P position.
- (3) Pull out the dipstick and wipe it clean.
- (4) Push it back fully into the pipe.
- (5) Pull it out and check that the fluid level is in the HOT range.

If the level is not within the range, add new fluid.

Fluid type: ATF TYPE T-IV

NOTICE:

Do not overfill.

(b) Check the fluid condition.

If the fluid smells burnt or is black, replace it.

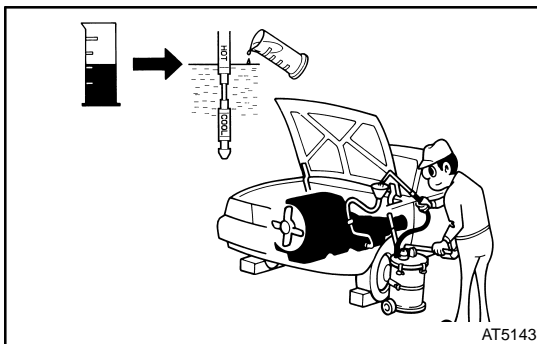

(c) Replace the ATF.

- (1) Remove the drain plug and drain the fluid.
- (2) Reinstall the drain plug securely.
- (3) With the engine OFF add new fluid through the oil filler pipe.

Fluid type: ATF TYPE T-IV

Capacity:

1.8 liters (1.9 US qts, 1.6 Imp. qts)

- (4) Start the engine and shift the shift lever into all positions from P to L position and then shift into P position.
- (5) With the engine idling, check the fluid level. Add fluid up to the COOL level on the dipstick.

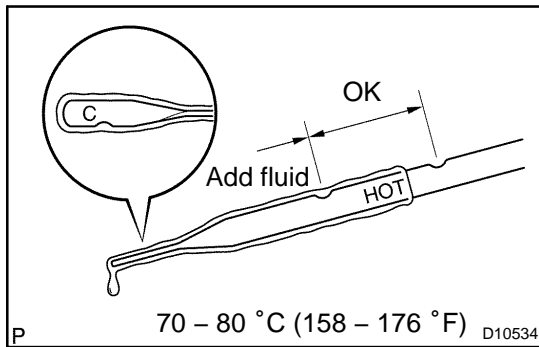

- (6) Check the fluid level is at the normal operating temperature, 70 – 80 °C (158 – 176 °F), and add as necessary.

NOTICE:**Do not overfill.**

- (d) Check the fluid leaks.

Check for leaks in the transmission.

If there are leaks, it is necessary to repair or replace O-rings, FIPGs, oil seals, plugs or other parts.

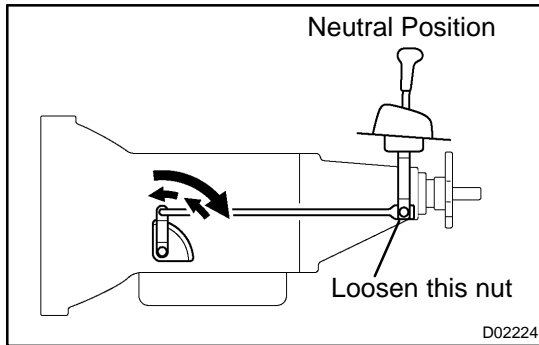

- (e) Inspect and adjust the shift lever position.

When shifting the shift lever from the N position to other positions, check that the lever can be shifted smoothly and accurately to each position and that the position indicator is aligned with the correct position.

If the indicator is not aligned with the correct position, carry out the following adjustment procedures.

- Loosen the nut on the shift lever.
- Push the control shaft fully rearward.
- Return the control shaft lever 2 notches to N position.
- Set the shift lever to N position.
- While holding the shift lever lightly toward the R position side, tighten the shift lever nut.

Torque: 13 N·m (130 kgf·cm, 10 ft·lbf)

- Start the engine and make sure that the vehicle moves forward when shifting the lever from the N to D position and reverses when shifting it to the R position.

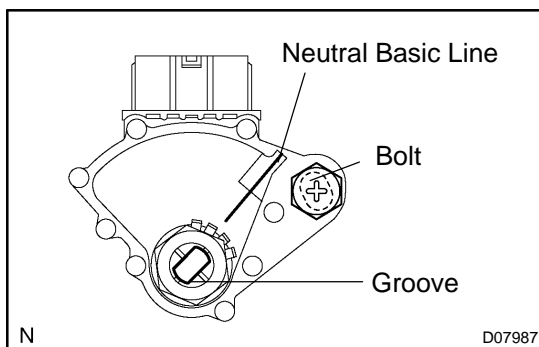

- (f) Inspect and adjust the park/neutral position switch.

- Check that the engine can be started with the shift lever only in the N or P position, but not in other positions.

If it is not as stated above, carry out the following adjustment procedures.

- Loosen the park/neutral position switch bolt and set the shift lever to the N position.
- Align the groove and neutral basic line.
- Hold the switch in position and tighten the bolt.

Torque: 13 N·m (130 kgf·cm, 10 ft·lbf)

- For continuity inspection of the park/neutral position switch, see page [DI-261](#).

- (g) Check the idle speed.

Idle speed (In N position and air conditioner OFF):
750 ± 50 rpm

7. MECHANICAL SYSTEM TESTS

(a) Measure the stall speed.

The object of this test is to check the overall performance of the transmission and engine by measuring the stall speeds in the D position.

NOTICE:

- **Do the test at normal operating fluid temperature 50 – 80 °C (122 – 176 °F).**
- **Do not continuously run this test for longer than 5 seconds.**
- **To ensure safety, conduct this test in a wide, clear level area which provides good traction.**
- **The stall test should always be carried out in pairs. One technician should observe the conditions of wheels or wheel stoppers outside the vehicle while the other is doing the test.**
 - Chock the 4 wheels.
 - Connect an OBD II scan tool or hand-held tester to DLC3.
 - Fully apply the parking brake.
 - Keep your left foot depressing firmly on the brake pedal.
 - Start the engine.
 - Shift into the D position. Press all the way down on the accelerator pedal with your right foot. Quickly read the stall speed at this time.

Stall speed:

2,450 ± 150 rpm (In D position)

Evaluation:

Problem	Possible cause
(a) Stall speed low in D position	<ul style="list-style-type: none"> • Engine output may be insufficient • Stator one-way clutch is operating properly <p>HINT: If the value is larger or smaller than the specified value by 600 rpm or more, the torque converter could be faulty.</p>
(b) Stall speed high in D position	<ul style="list-style-type: none"> • Line pressure too low • Forward clutch slipping • No. 2 one-way clutch not operating properly • O/D one-way clutch not operating properly

(b) Measure the time lag.

When the shift lever is shifted while the engine is idling, there will be a certain time lapse or lag before the shock can be felt. This is used for checking the condition of the O/D direct clutch, forward clutch, and 1st & reverse brake.

NOTICE:

- **Do the test at normal operating fluid temperature 50 – 80 °C (122 – 176 °F).**
- **Be sure to allow 1 minute interval between tests.**
- **Take 3 measurements and take the average value.**
 - Fully apply the parking brake.
 - Start the engine and check idle speed.

Idle speed (In N position and air conditioner OFF):

750 ± 50 rpm

- Shift the shift lever from N to D position. Using a stop watch, measure the time from when the lever is shifted until the shock is felt.

Time lag: N → D Less than 1.2 seconds

- In the same manner, measure the time lag for N → R.

Time lag: N → R Less than 1.5 seconds

Evaluation (If N → D time or N → R time lag is longer than the specified):

Problem	Possible cause
N → D time lag is longer	<ul style="list-style-type: none"> • Line pressure too low • Forward clutch worn • O/D one-way clutch not operating properly
N → R time lag is longer	<ul style="list-style-type: none"> • Line pressure too low • Direct clutch worn • 1st & reverse brake worn • O/D one-way clutch not operating properly

8. HYDRAULIC TEST

Measure the line pressure.

NOTICE:

- **Do the test at normal operation fluid temperature 50 – 80 °C (122 – 176 °F).**
- **The line pressure test should always be carried out in pairs. One technician should observe the conditions of wheels or wheel stoppers outside the vehicle while the other is doing the test.**
- **Be careful to prevent SST's hose from interfering with the exhaust pipe.**

(1) Warm up the ATF.

(2) Remove the test plug on the front left side of the transmission case and connect SST (See page [AT-32](#) for the location to connect SST).

SST 09992-00095 (09992-00231, 09992-00271)

(3) Fully apply the parking brake and chock the 4 wheels.

(4) Start the engine and check idling speed.

(5) Keep your left foot pressing firmly on the brake pedal and shift into D position.

(6) Measure the line pressure when the engine is idling.

(7) Depress the accelerator pedal all the way down. Quickly read the highest line pressure when engine speed reaches stall speed.

(8) In the same manner, do the test in R position.

Specified line pressure:

Condition	D position kPa (kgf/cm ² , psi)	R position kPa (kgf/cm ² , psi)
Idling	395 – 455 (4.0 – 4.6, 57 – 65)	0
Stall	1,200 – 1,360 (12.2 – 13.8, 174 – 196)	1,655 – 1,960 (16.9 – 19.8, 240 – 282)

If the measured pressures are not up to the specified values, recheck the throttle cable adjustment and re-test.

Evaluation:

Problem	Possible cause
If the measured values at all positions are higher	<ul style="list-style-type: none"> • Shift solenoid valve SLT defective • Regulator valve defective
If the measured values at all positions are lower	<ul style="list-style-type: none"> • Shift solenoid valve SLT defective • Regulator valve defective • Oil pump defective • O/D direct clutch defective
If pressure is low in the D position only	<ul style="list-style-type: none"> • D position circuit fluid leakage • Forward clutch defective
If pressure is low in the R position only	<ul style="list-style-type: none"> • R position circuit fluid leakage • Direct clutch defective • 1st & reverse brake defective

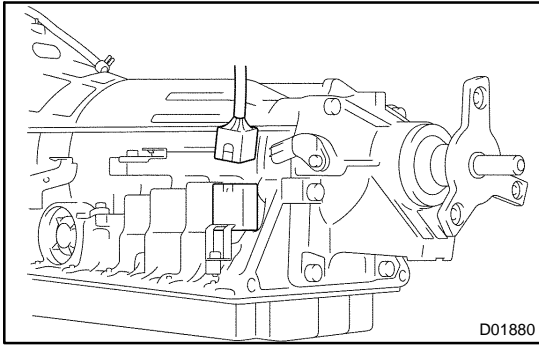

9. MANUAL SHIFTING TEST

The purpose of this manual shifting test is to determine whether a problem is caused by either mechanical or electrical factors. Disconnecting the solenoid wire disables electrically-controlled automatic gear shifting. In this case, operating the shift level is the only way to shift the transmission gear. If the gear is not changed by shift lever operation, it is assumed that there is a mechanical problem.

- (a) Turn the ignition switch OFF.
- (b) Disconnect the solenoid wire connector.
- (c) Warm up the engine.
- (d) Drive the vehicle.
- (e) Check the transmission operation when the shift lever is moved into L, 2, 3, 4 and D ranges.

Standard:

Shift Lever	Operation
L to 2	No shift (Not change)
2 to 3	Up shift
3 to 4	Up shift
4 to D	No shift (Not change)
D to 4	No shift (Not change)
4 to 3	Down shift
3 to 2	Down shift
2 to L	No shift (Not change)

- (f) Turn the ignition switch OFF.
- (g) Connect the solenoid wire connector.
- (h) Clear DTCs.

HINT:

When the solenoid wire is disconnected, the transmission gear will be set as listed below:

Shift Lever	Gear
P	Parking
R	Reverse
N	Neutral
D and 4	5th
3	4th
2 and L	3rd