

<b>DTC</b>	<b>C1787</b>	<b>ABSORBER CONTROL SWITCH CIRCUIT (TEST DIAGNOSIS)</b>
------------	--------------	---

### CIRCUIT DESCRIPTION

The absorber control switch is used to select the attenuation modes of the shock absorber. 2 levels of attenuation, "SPORT" and "NORM", are available.

DTC No.	DTC Detecting Condition	Trouble Area
C1787	Absorber control switch signal does not change.	<ul style="list-style-type: none"> <li>• Absorber control switch</li> <li>• Absorber control switch circuit</li> <li>• Suspension control ECU</li> </ul>

HINT:

DTC C1787 is output only in the test mode.

### WIRING DIAGRAM

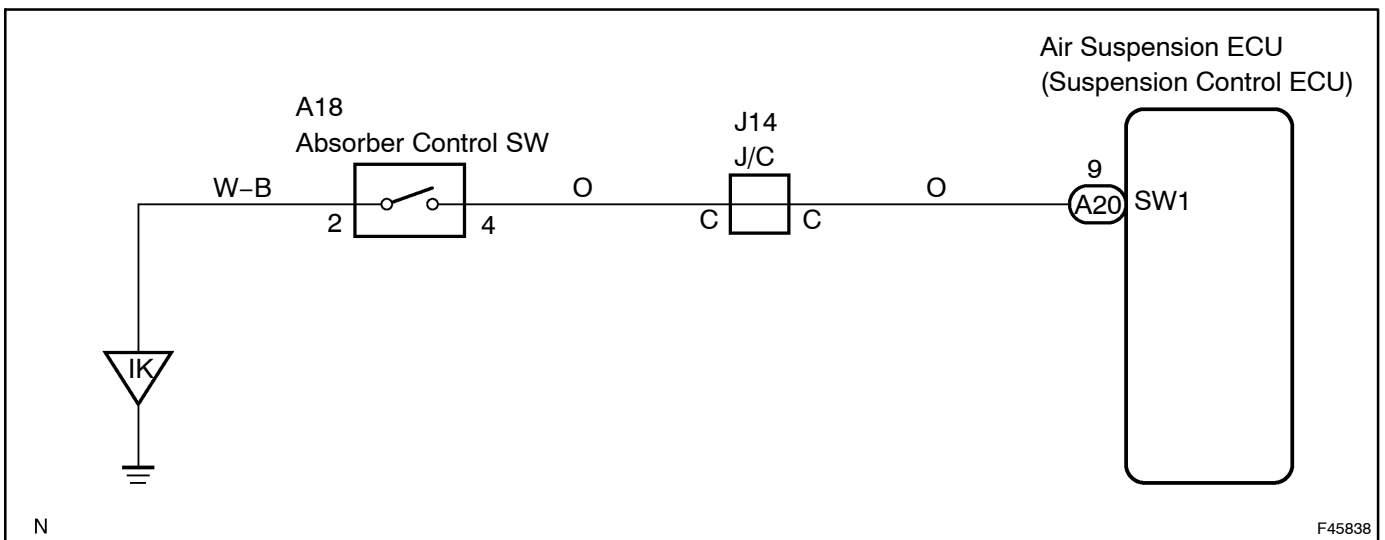

# INSPECTION PROCEDURE

## 1 INSPECT ABSORBER CONTROL SWITCH

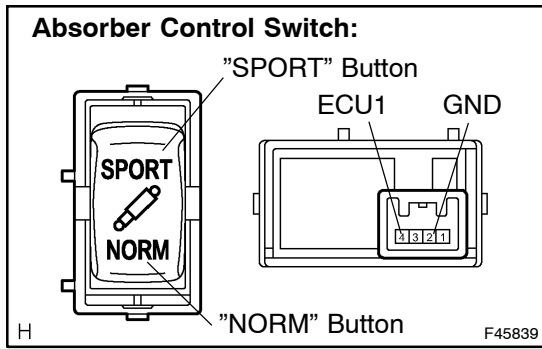

- (a) Disconnect the absorber control switch connector.
- (b) Measure the resistance according to the value(s) in the table below.

**Standard:**

Switch Condition	Tester Connection	Specified Condition
"SPORT"	2 (GND) - 4 (ECU1)	Below 1 Ω
"NORM"	2 (GND) - 4 (ECU1)	10 kΩ or higher

**NG** → REPLACE ABSORBER CONTROL SWITCH

**OK**

## 2 CHECK HARNESS AND CONNECTOR(SUSPENSION CONTROL ECU - ABSORBER CONTROL SWITCH) (SEE PAGE 01-42)

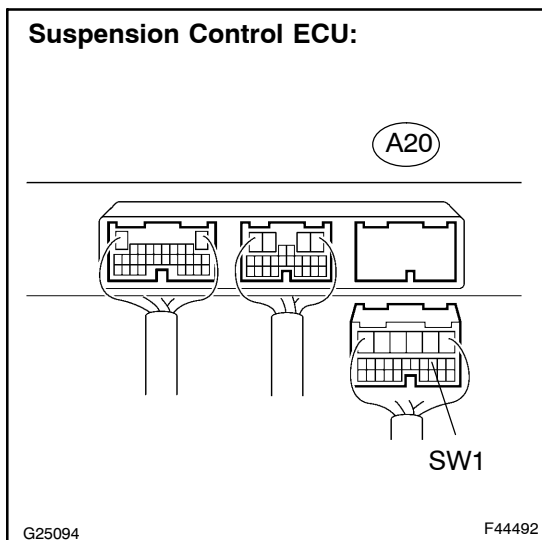

- (a) Disconnect the suspension control ECU A20 connector.
- (b) Measure the resistance according to the value(s) in the table below.

**Standard:**

Tester Connection	Specified Condition
A20-9 (SW1) - A18-4 (ECU1)	Below 1 Ω
A20-9 (SW1) - Body ground	10 kΩ or higher

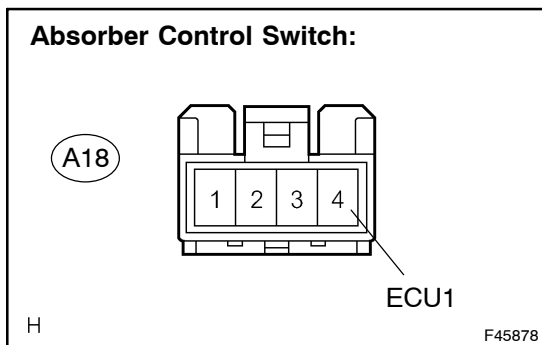

**NG** → REPAIR OR REPLACE HARNESS OR CONNECTOR

**OK**

**3 CHECK HARNESS AND CONNECTOR(ABSORBER CONTROL SWITCH - BODY GROUND) (SEE PAGE 01-42)**

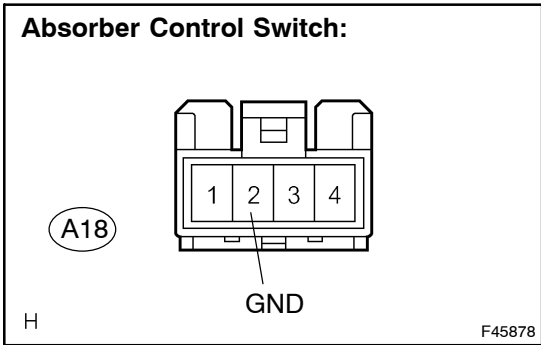

(a) Measure the resistance according to the value(s) in the table below.

**Standard:**

Tester Connection	Specified Condition
A18-2 (GND) - Body ground	Below 1Ω

**NG** REPAIR OR REPLACE HARNESS OR CONNECTOR

**OK**

**REPLACE SUSPENSION CONTROL ECU (SEE PAGE 25-20)**