

INSPECTION

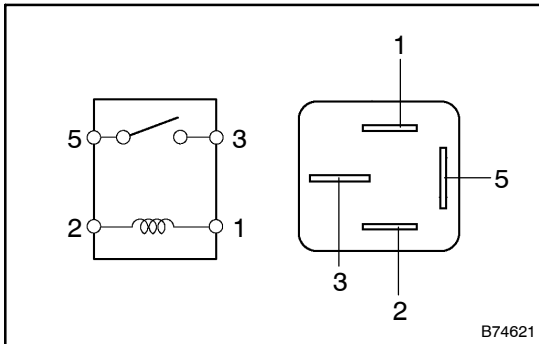

B74621

1. INSPECT RELAY (Marking: RR S/SHADE)

- (a) Remove the RR S/SHADE relay from the luggage room J/B.
- (b) Measure the resistance of the RR S/SHADE relay.

Standard:

Tester Connection	Specified Condition
3 - 5	10 kΩ or higher
3 - 5	Below 1 Ω (when battery voltage is applied to terminals 1 and 2)

If the result is not as specified, replace the relay.

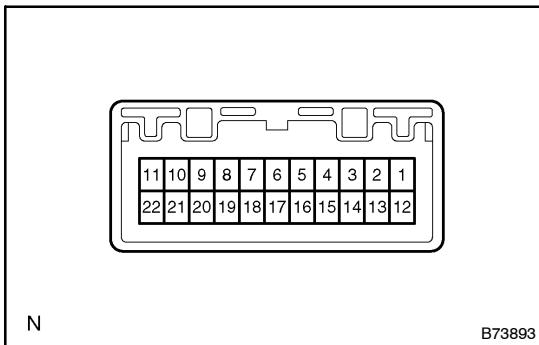

B73893

2. INSPECT TRACTION CONTROL SWITCH (REAR SUNSHADE SWITCH FOR FRONT SIDE)

- (a) Measure the resistance of the switch.

Standard:

Tester Connection	Switch Condition	Specified Condition
6 - 7	ON	Below 1 Ω
6 - 7	OFF	10 kΩ or higher

If the result is not as specified, replace the switch.

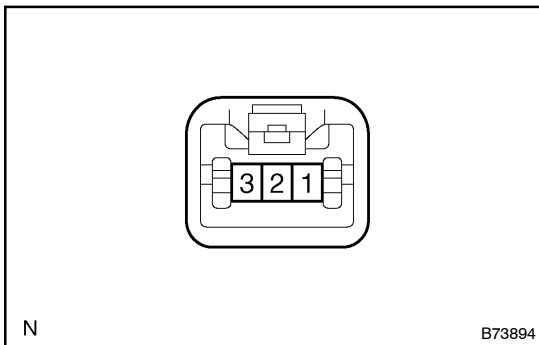

B73894

3. INSPECT REAR SUNSHADE SWITCH (REAR SIDE)

- (a) Measure the resistance of the switch.

Standard:

Tester Connection	Switch Condition	Specified Condition
1 - 2	ON	Below 1 Ω
1 - 2	OFF	10 kΩ or higher

If the result is not as specified, replace the switch.

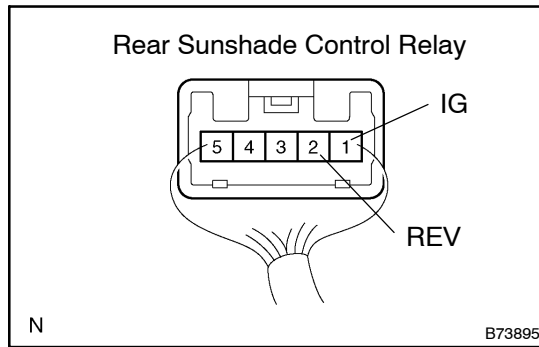

- 4. INSPECT LUGGAGE ROOM JUNCTION BLOCK ECU**
- Disconnect the relay connector.
 - Measure the voltage of each terminal of the wire harness side connector.

Standard:

Tester Connection	Condition	Specified Condition
1 (IG) - Body ground	Ignition switch ON	10 to 14 V
1 (IG) - Body ground	Ignition switch OFF or ACC	Below 1 V
2 (REV) - Body ground	Ignition switch ON, Shift position R	10 to 14 V
2 (REV) - Body ground	Ignition switch ON, Shift position P	Below 1 V

If the result is not as specified, luggage room J/B ECU or wire harness may have a malfunction.

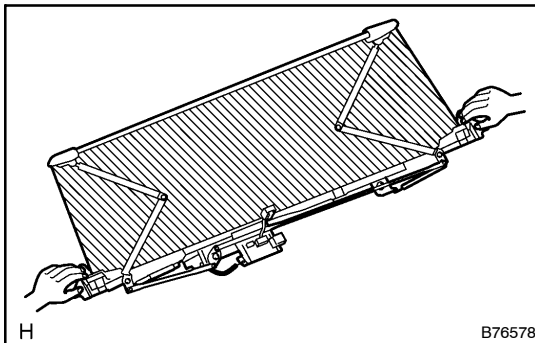

5. INSPECT REAR SUNSHADE (MOTOR OPERATION)

- Hold the edge of the rear sunshade with your hands, as shown in the illustration.

CAUTION:

Be careful when the rear sunshade raises and lowers. Something could get caught in the rear sunshade and cause an injury.

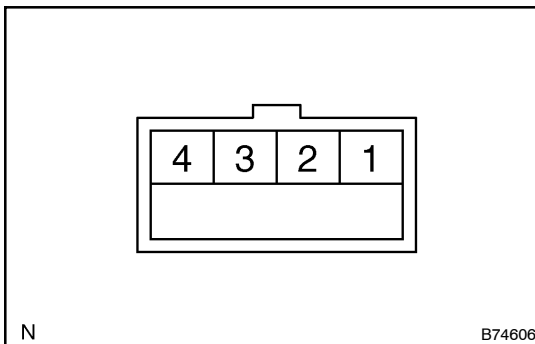

- Connect the battery's positive (+) lead to terminal 4 and negative (-) lead to terminal 3. Check that the rear sunshade moves up.
- Reverse the polarity and check that the rear sunshade moves down.

NOTICE:

To prevent the motor from being burned, stop operation as soon as the rear sunshade is fully turned up or down.

If all the check results are as specified above and normal wire harness is confirmed, replace the rear sunshade control relay (see page 76-49).