

OPERATION CHECK

1. DETECTION RANGE MEASUREMENT AND DISPLAY CHECK

- (a) Turn the ignition switch to the ON position.
- (b) Move the shift lever to the D position (when the front sonar and the front clearance sonar are checked).
- (c) Move the shift lever to the R position (when the back sonar and the rear clearance sonar are checked).

NOTICE:

Apply the parking brake securely so that the vehicle does not move.

- (d) Turn the clearance sonar main switch on.
- (e) Move a \varnothing 60 mm (2.36 in.) pole around the sensor to measure the detection range of the sensor.

NOTICE:

The measured detection range is for a \varnothing 60 mm (2.36 in.) pole. The detection range for walls and other obstacles is different.

Front and back sonar's detection range:

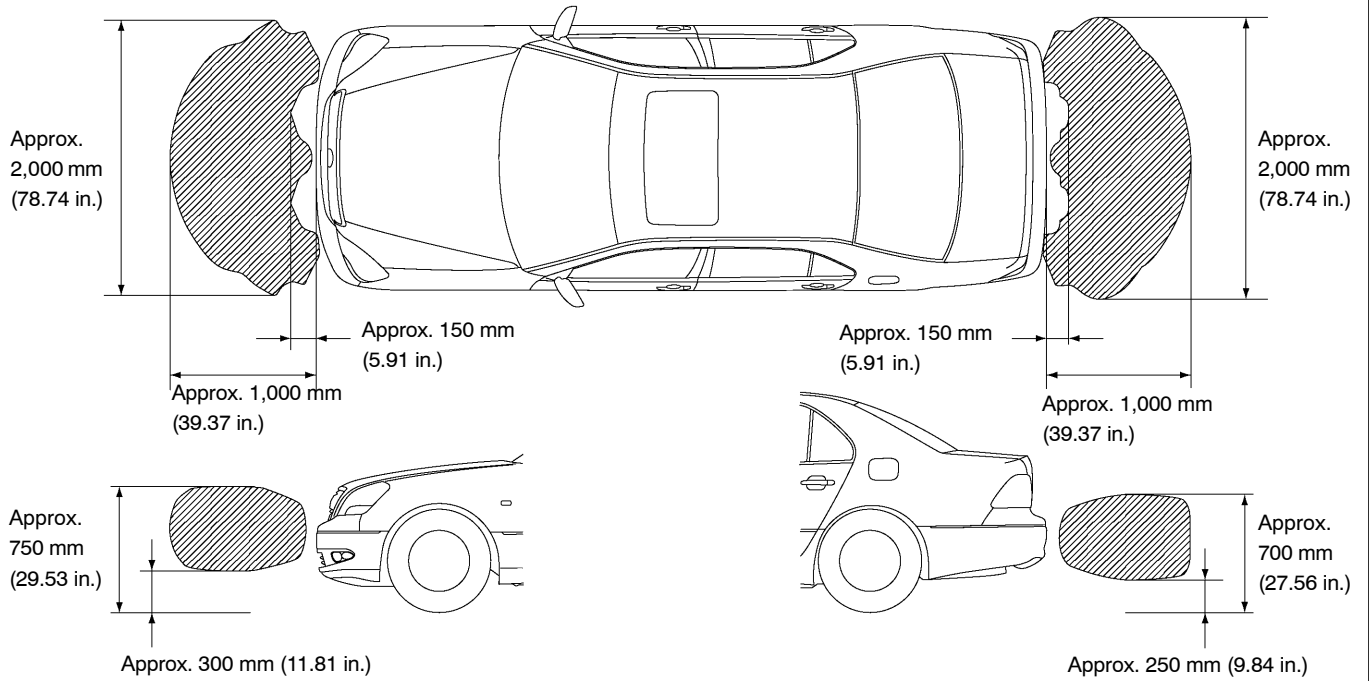

Clearance sonar detection range:

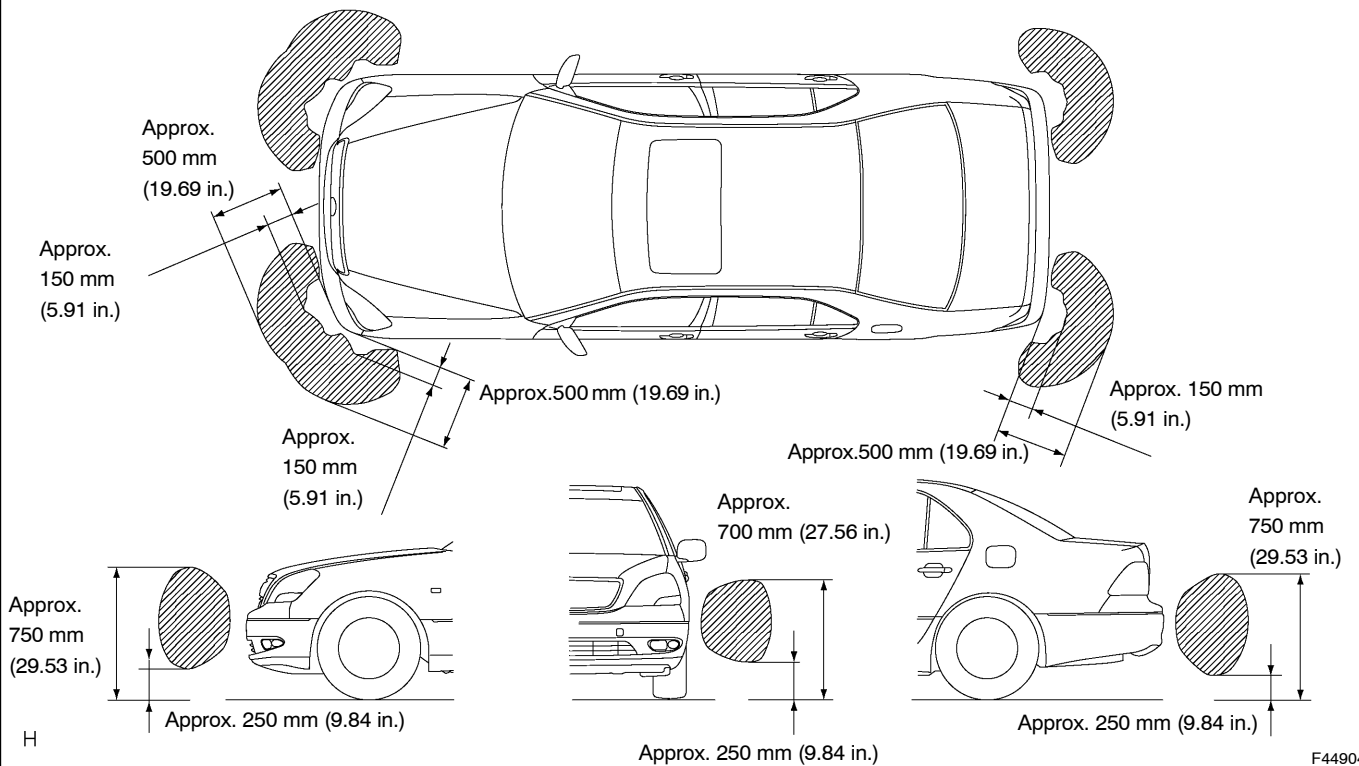

- (f) Check the multi-information display, the multi-display and the buzzer sounding condition when the front sensor detects an obstacle.

Operation condition:

Front sonar:

Ignition switch	Clearance sonar main switch	Shift position	Vehicle speed	Engine speed
ON	ON	In any position except P and R	10 km/h (6 mph) or less	N position: 1,500 rpm or less Except N position: 2,500 rpm or less

HINT:

Because sound waves are used for detection range measurement, the detection range may change slightly due to the peripheral temperature.

Front sonar display:

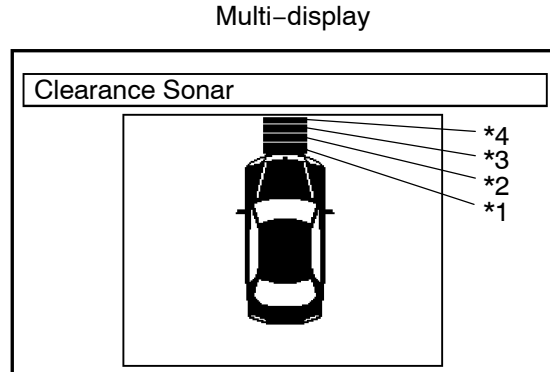
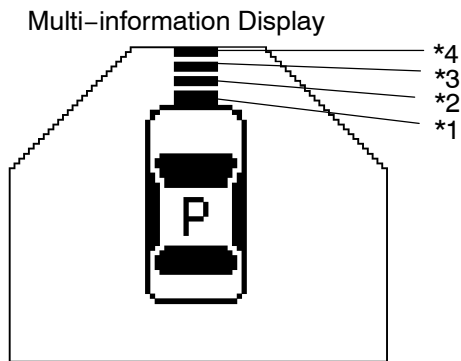

- *1. Close-range detection (blink)
- *2. Medium-range detection
- *3. Long-range detection
- *4. Maximum long-range detection

Buzzer Sound

*1: Close-range detection
Within approx. 250 mm (9.84 in.)



*2: Medium-range detection
From approx. 250 to 375 mm
(9.84 to 14.76 in.)

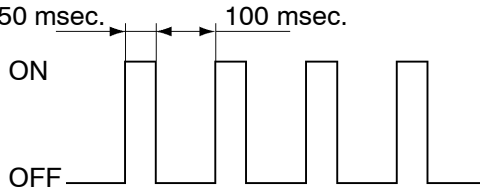

*3: Long-range detection
From approx. 375 to 500 mm
(14.76 to 19.69 in.)

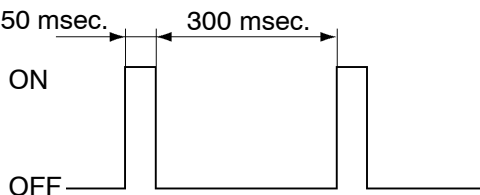

*4: Maximum long-range detection
From approx. 500 to 1,000 mm
(19.69 to 39.37 in.)

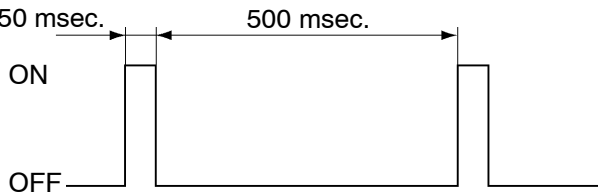

- (g) Check the multi-information display and the buzzer sounding condition when the back sensor detects an obstacle.

Operation condition:**Back sonar:**

Ignition switch	Clearance sonar main switch	Shift position	Vehicle speed	Engine speed
ON	ON	R position	10 km/h (6 mph) or less	2,500 rpm or less

HINT:

- Clearance sonar display does not appear on the multi-display if the shift lever is moved to the R position.
- Because sound waves are used for detection range measurement, the detection range may change slightly due to the peripheral temperature.

Back sonar display:

Multi-information Display

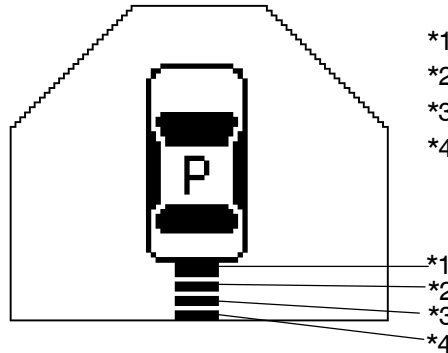

- *1. Close-range detection (blink)
- *2. Medium-range detection
- *3. Long-range detection
- *4. Maximum long-range detection

Buzzer Sound

*1: Close-range detection
Within approx. 250 mm (9.84 in.)

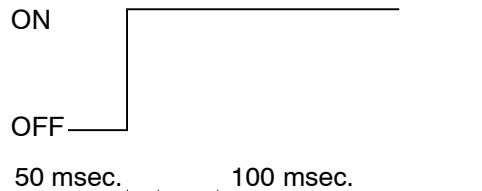

*2: Medium-range detection
From approx. 250 to 375 mm
(9.84 to 14.76 in.)

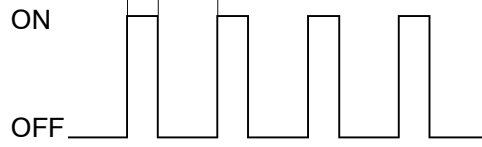

*3: Long-range detection
From approx. 375 to 500 mm
(14.76 to 19.69 in.)

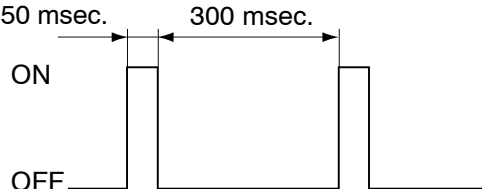

*4: Maximum long-range detection
From approx. 500 to 1,000 mm
(19.69 to 39.37 in.)

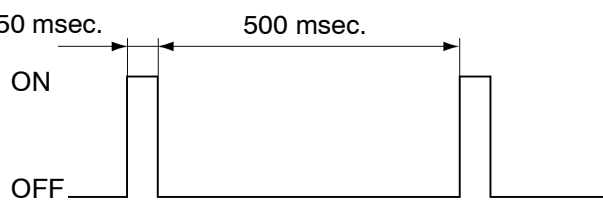

- (h) Check the multi-information display, the multi-display and the buzzer sounding condition when the clearance sonar sensor detects an obstacle.

Operation condition:

Front clearance sonar:

Ignition switch	Clearance sonar main switch	Shift position	Vehicle speed	Engine speed
ON	ON	In any position except P and R	10 km/h (6 mph) or less	N position 1,500 rpm or less Except N position 2,500 rpm or less

Rear clearance sonar:

Ignition switch	Clearance sonar main switch	Shift position	Vehicle speed	Engine speed
ON	ON	R position	10 km/h (6 mph) or less	2,500 rpm or less

HINT:

- Clearance sonar display does not appear on the multi-display if the shift lever is moved to the R position.
- Because sound waves are used for detection range measurement, the detection range may change slightly due to the peripheral temperature.

Clearance sonar display:

Multi-information Display

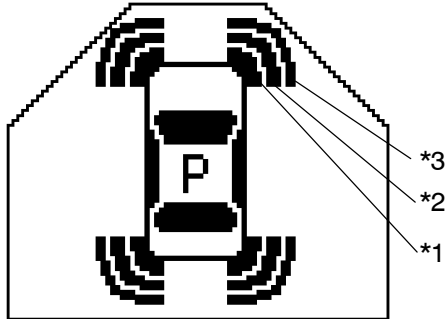

Multi-display

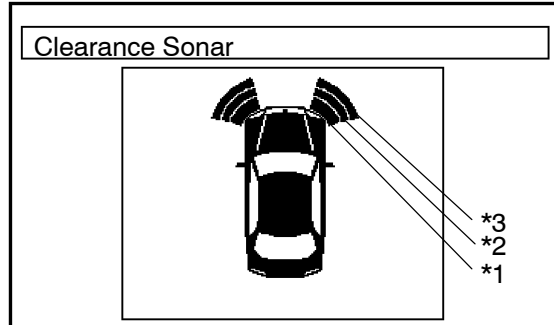

- *1. Close-range detection (blink)
- *2. Medium-range detection
- *3. Long-range detection

Buzzer Sound

*1: Close-range detection
Within approx. 250 mm (9.84 in.)

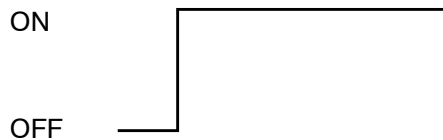

*2: Medium-range detection
From approx. 250 to 375 mm
(9.84 to 14.76 in.)

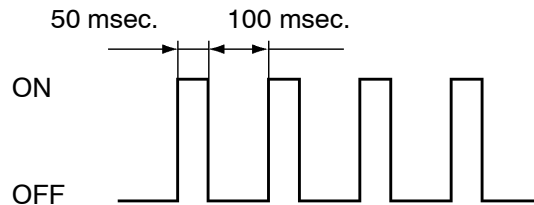

*3: Long-range detection
From approx. 375 to 500 mm
(14.76 to 19.69 in.)

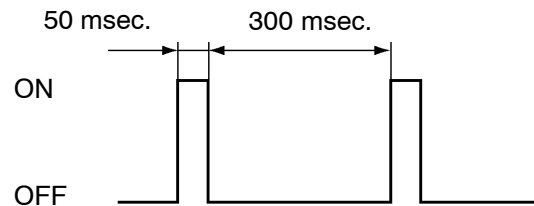

2. INITIAL CHECK FUNCTION CHECK

- (a) Turn the ignition switch to the ON position.
- (b) Drive the engine at 2,500 rpm or less with the shift lever in any position except N, or at 1,500 rpm or less with the shift lever in the N position.
- (c) After turning the ignition switch to the ON position, wait for 2 seconds or more, then turn the clearance sonar main switch on. Check the multi-information display and the buzzer sounding condition.

Standard:

After the main switch is turned on, the multi-information display shows the figure below for approximately 2 seconds and the buzzer sounds for approximately 1 second then the detection mode begins.

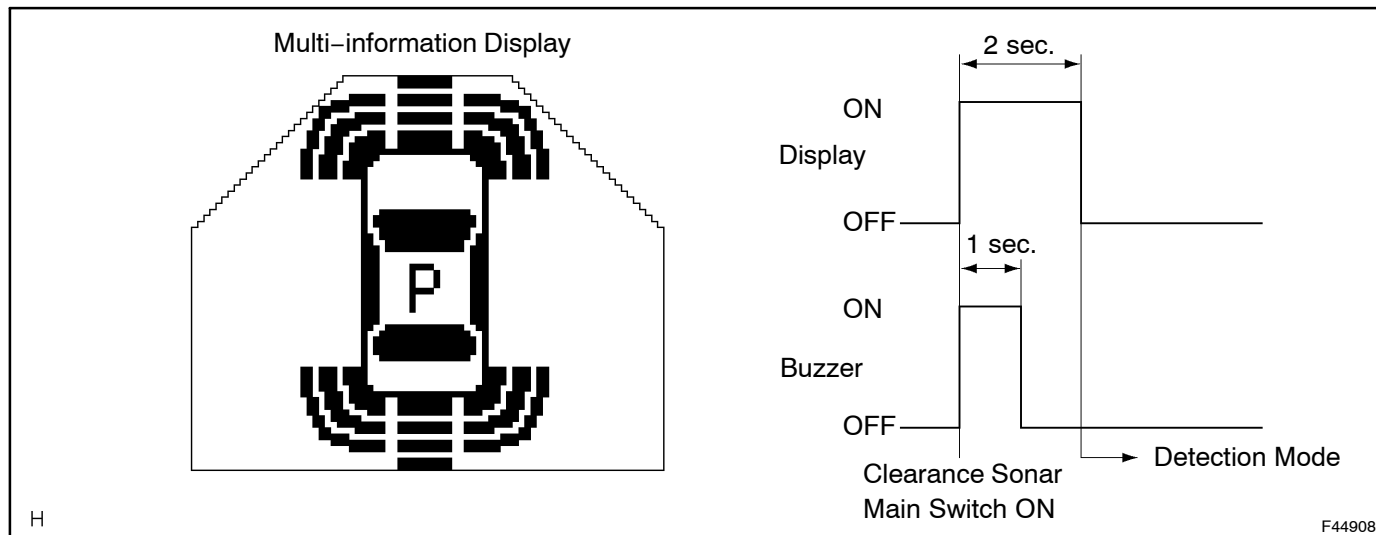

HINT:

- Multi-information display:
The malfunctioning sensor blinks on the display when the wire harness or the connector is faulty and requires repair or replacement, or when trouble is detected in the ultrasonic sensor circuits. After the sensor operation returns to normal, the detection mode will finish normally.

Example of trouble detection display (Multi-information Display):

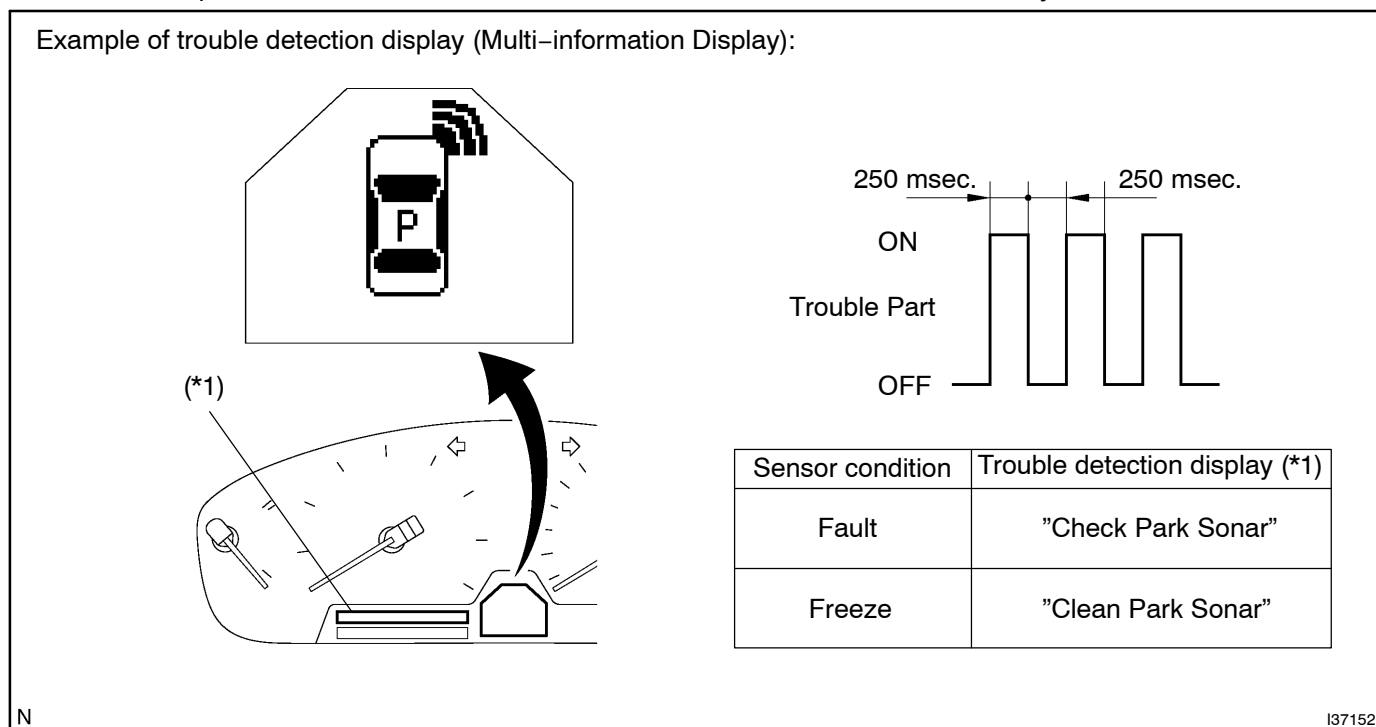

- Multi-display:
The malfunctioning sensor is displayed when the wire harness or the connector is faulty and requires repair or replacement, or when trouble is detected in the ultrasonic sensor circuits. After the sensor operation returns to normal, the detection mode will finish normally.

Example of trouble detection display (Multi-display):

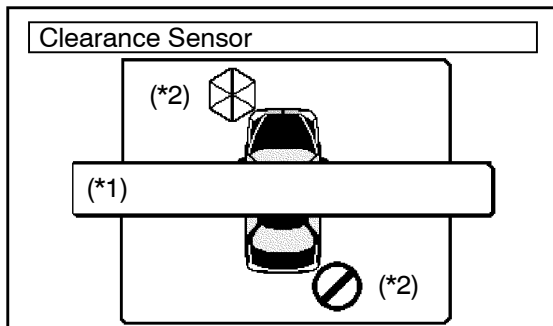

Sensor condition	Trouble detection display (*1)	Icon (*2)
Fault	"Check Sonar"	An icon indicating a malfunction will appear on the screen in the appropriate location.
Freeze	"Clean Sonar"	An icon indicating a frozen sensor will appear on the screen in the appropriate location.