

# FRONT SUSPENSION LOWER ARM ASSY LH

## REPLACEMENT

260H2-01

### HINT:

- Use the same procedures for the RH side and LH side.
- The procedures listed below are for the LH side.

### 1. REMOVE FRONT WHEELS

### 2. REMOVE LOWER BALL JOINT ASSY FRONT LH (SEE PAGE 26-29)

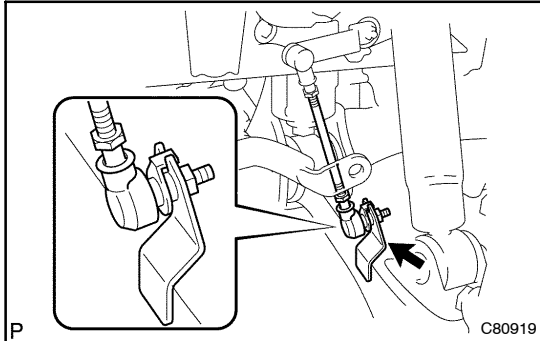

### 3. SEPARATE HEIGHT CONTROL SENSOR LINK SUB-ASSY FRONT

- (a) Remove the nut and separate the height control sensor link sub-assy front.

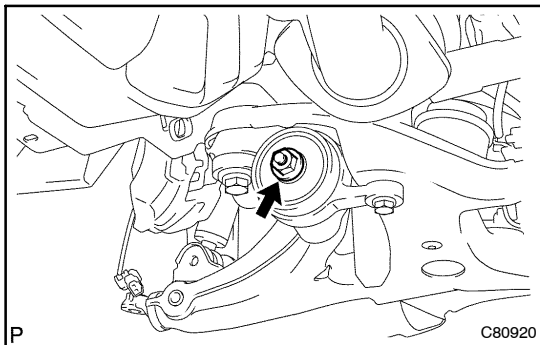

### 4. REMOVE FRONT SUSPENSION LOWER ARM ASSY LH

- (a) Loosen the nut.

#### NOTICE:

**Do not remove the nut.**

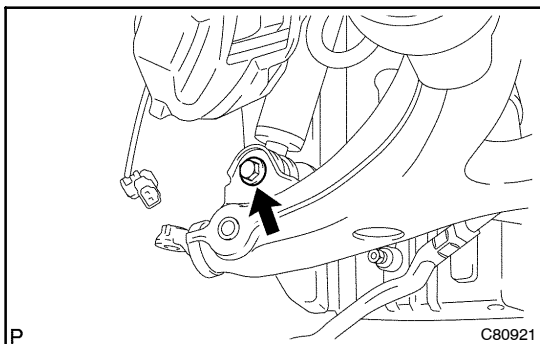

- (b) Remove the shock absorber assy lower side bolt and nut.

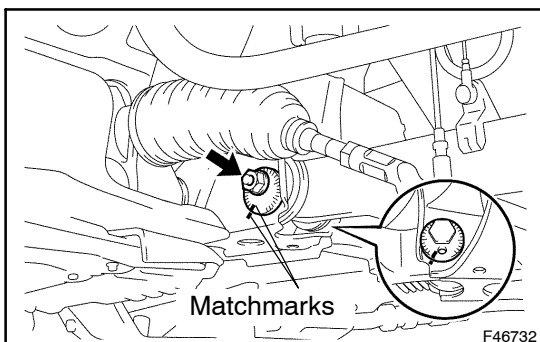

- (c) Place matchmarks on the camber adjust cam and suspension member.
- (d) Remove the nut, camber adjust cam and camber adjust cam bolt.

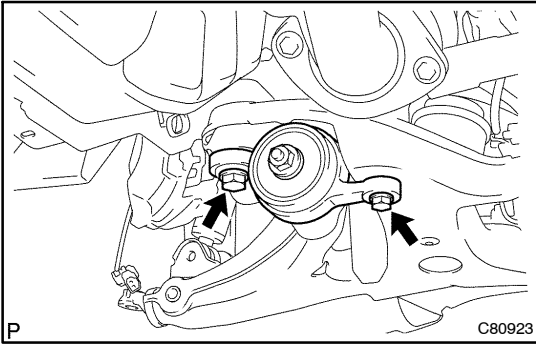

- (e) Remove the 2 bolts and front suspension lower arm assy LH.

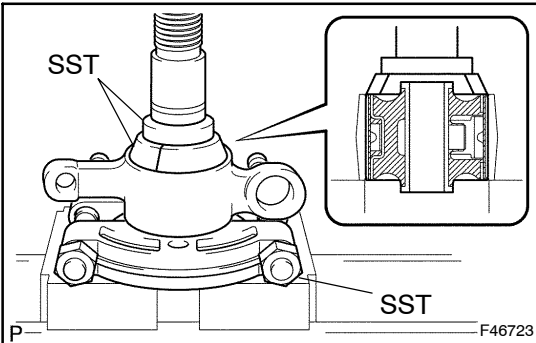

### 5. REMOVE FRONT LOWER ARM BRACKET

- (a) Remove the nut, washer, lower arm bracket and lower arm bushing stopper.  
 (b) Using SST and a press, remove the bushing from the lower arm bracket.

SST 09613-26010, 09950-00020,  
 09950-60010 (09951-00650)

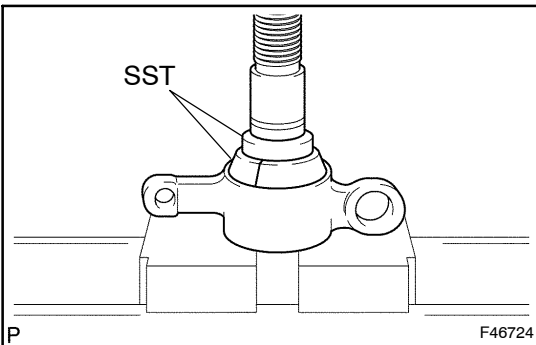

### 6. INSTALL FRONT LOWER ARM BRACKET

- (a) Using SST and a press, install the bushing to the lower arm bracket sub-assy.

SST 09613-26010, 09950-60010 (09951-00650)

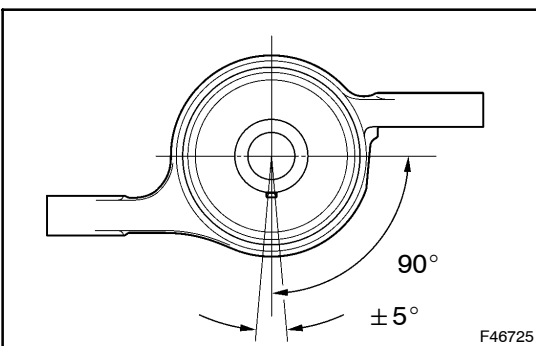

- (b) Temporarily install the front lower arm bushing stopper, lower arm bracket and washer to the lower arm bracket sub-assy with the nut.

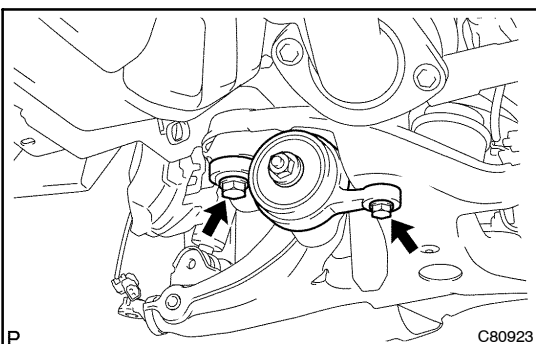

### 7. TEMPORARILY TIGHTEN FRONT SUSPENSION LOWER ARM ASSY LH

- (a) Install the front suspension lower arm assy LH.  
 (b) Temporarily install the 2 bolts.

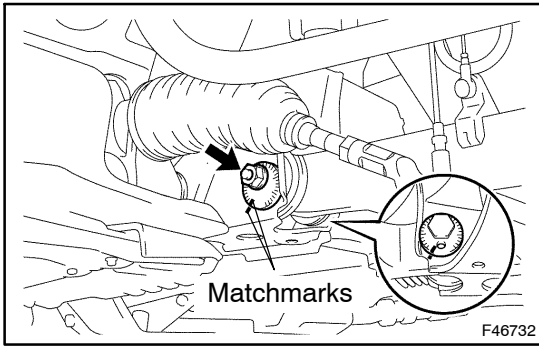

- (c) Align the matchmarks on the camber adjust cam and suspension member.
- (d) Temporarily install camber adjust cam bolt with the nut.

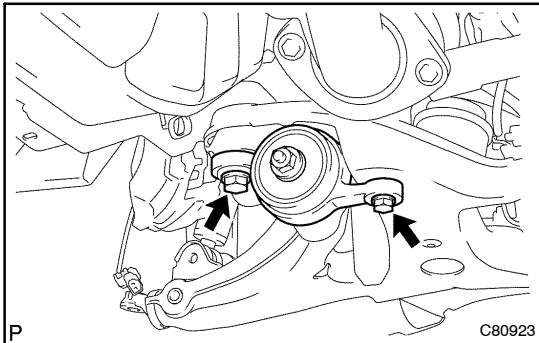

- (e) Fully tighten the 2 bolts.  
**Torque:**  
**Vehicle inside: 60 N·m (612 kgf·cm, 44 ft·lbf)**  
**Vehicle outside: 137 N·m (1,395 kgf·cm, 101 ft·lbf)**

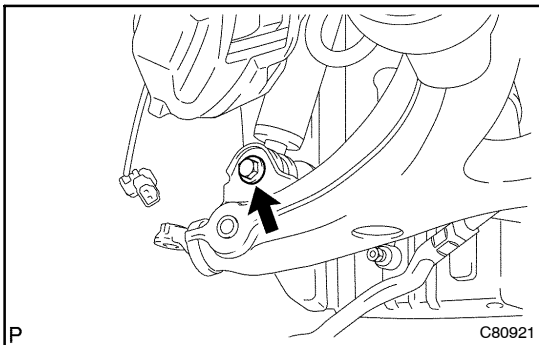

- (f) Install the shock absorber assy.
- (g) Temporarily install the bolt and nut.

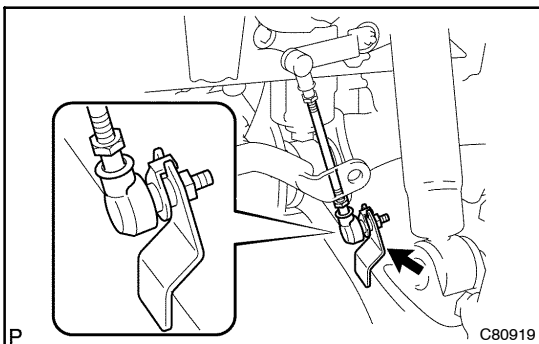

## 8. INSTALL HEIGHT CONTROL SENSOR LINK SUB-ASSY FRONT (AIR SUSPENSION)

- (a) Install the height control sensor link sub-assy front with the nut.  
**Torque: 5.4 N·m (55 kgf·cm, 48 in.·lbf)**

## 9. INSTALL LOWER BALL JOINT ASSY FRONT LH (SEE PAGE 26-29)

## 10. STABILIZE SUSPENSION (SEE PAGE 26-12 OR 26-18)

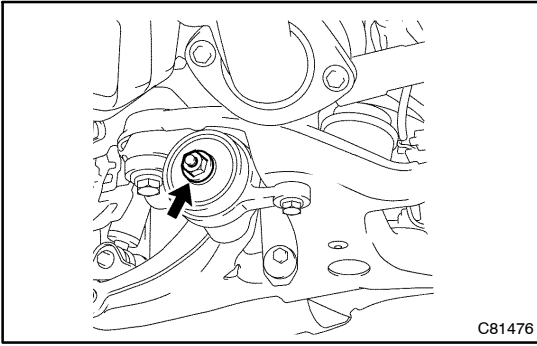

### 11. FULLY TIGHTEN FRONT SUSPENSION LOWER ARM ASSY LH

- (a) Fully tighten the nut.  
**Torque: 137 N·m (1,395 kgf·cm, 101 ft·lbf)**

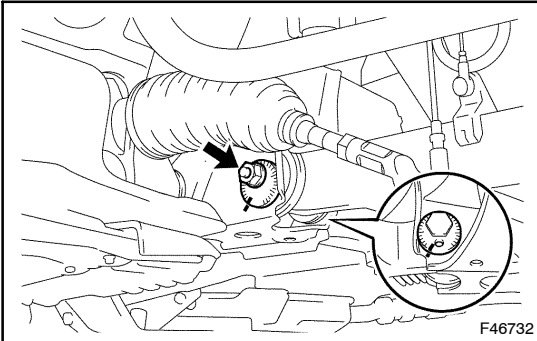

- (b) Fully tighten the nut.  
**Torque: 172 N·m (1,755 kgf·cm, 127 ft·lbf)**

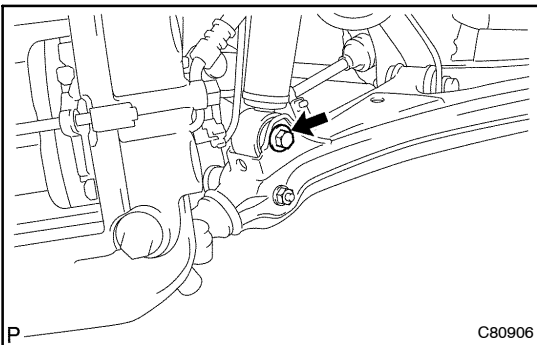

- (c) Fully tighten the bolt.  
**Torque: 157 N·m (1,600 kgf·cm, 116 ft·lbf)**

### 12. INSTALL FRONT WHEELS

**Torque: 103 N·m (1,050 kgf·cm, 76 ft·lbf)**

### 13. ADJUST FRONT WHEEL ALIGNMENT (SEE PAGE 26-8)

### 14. ADJUST VEHICLE HEIGHT (AIR SUSPENSION) (SEE PAGE 25-4)

### 15. CHECK ABS SPEED SENSOR SIGNAL (SEE PAGE 05-477)