

# PARTIAL ENGINE ASSY COMPONENTS

141MC-02

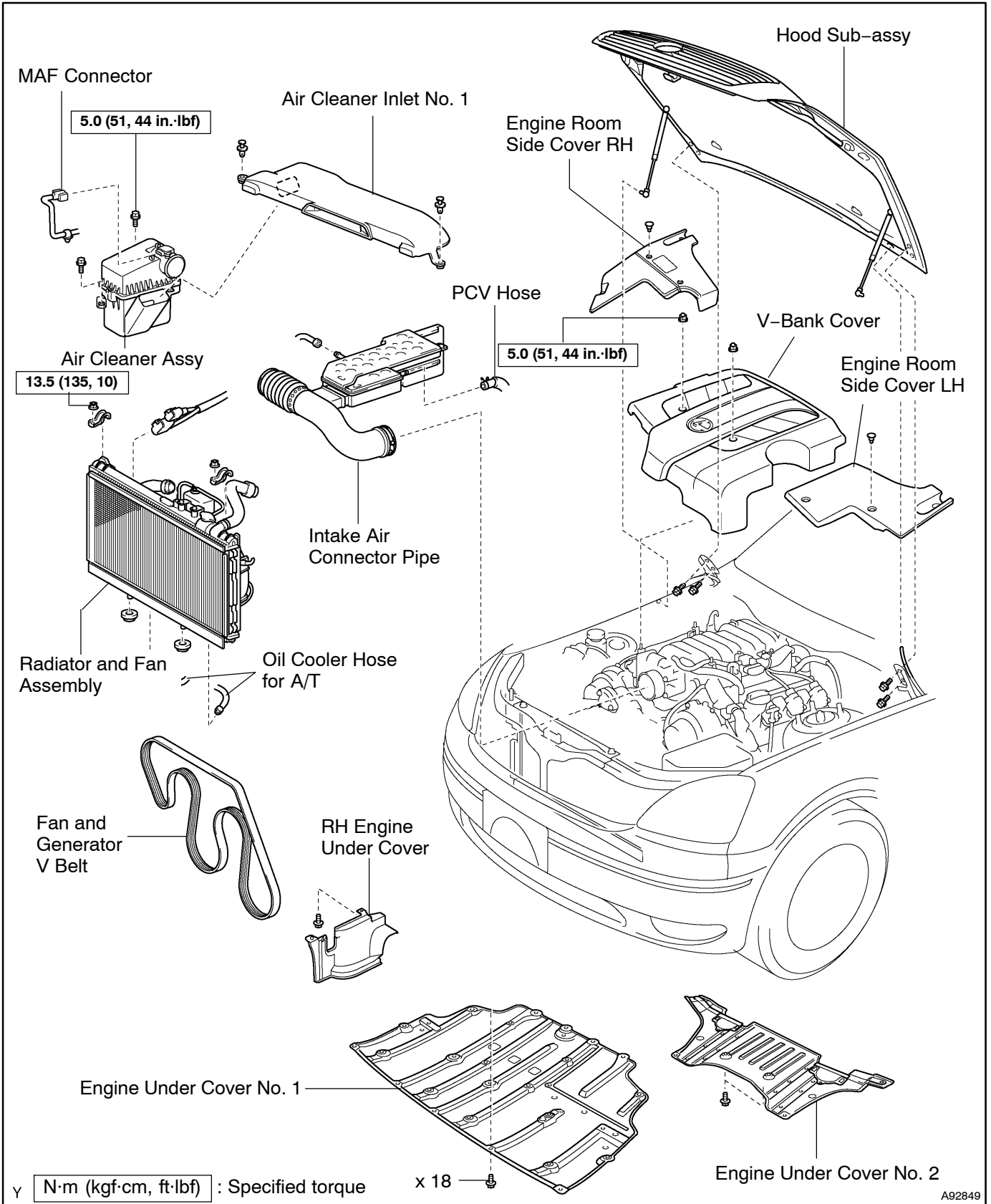

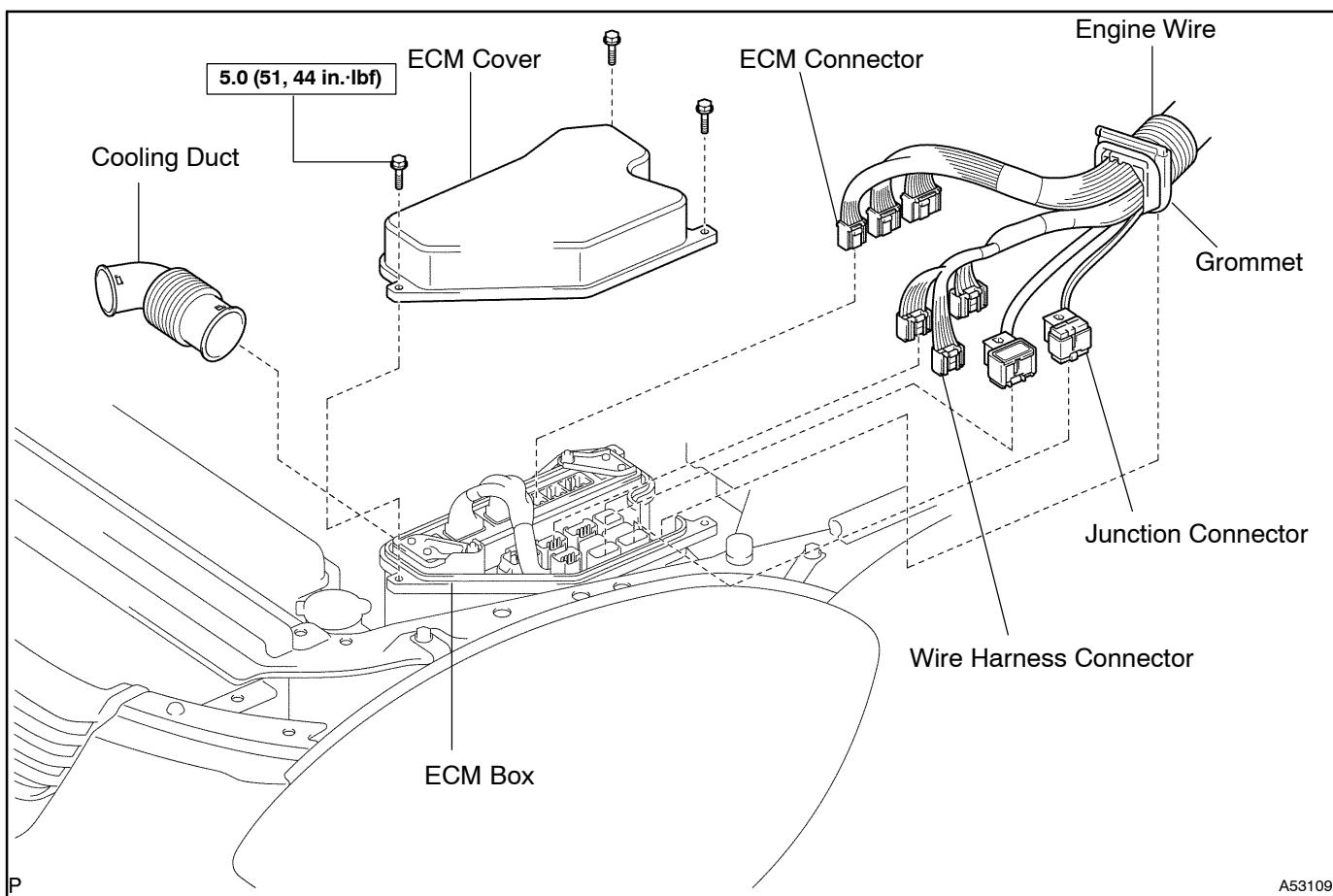

A53109

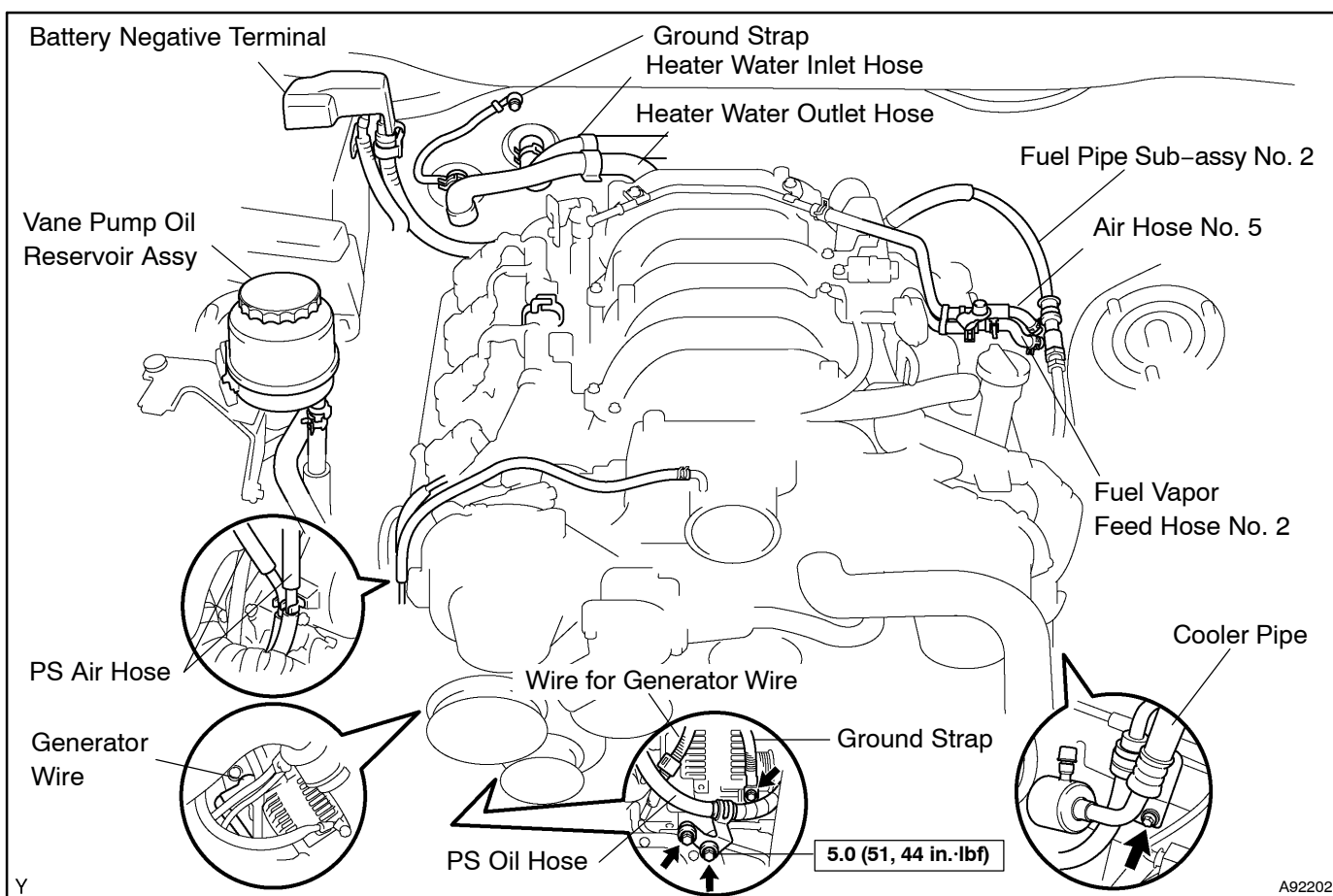

A92202

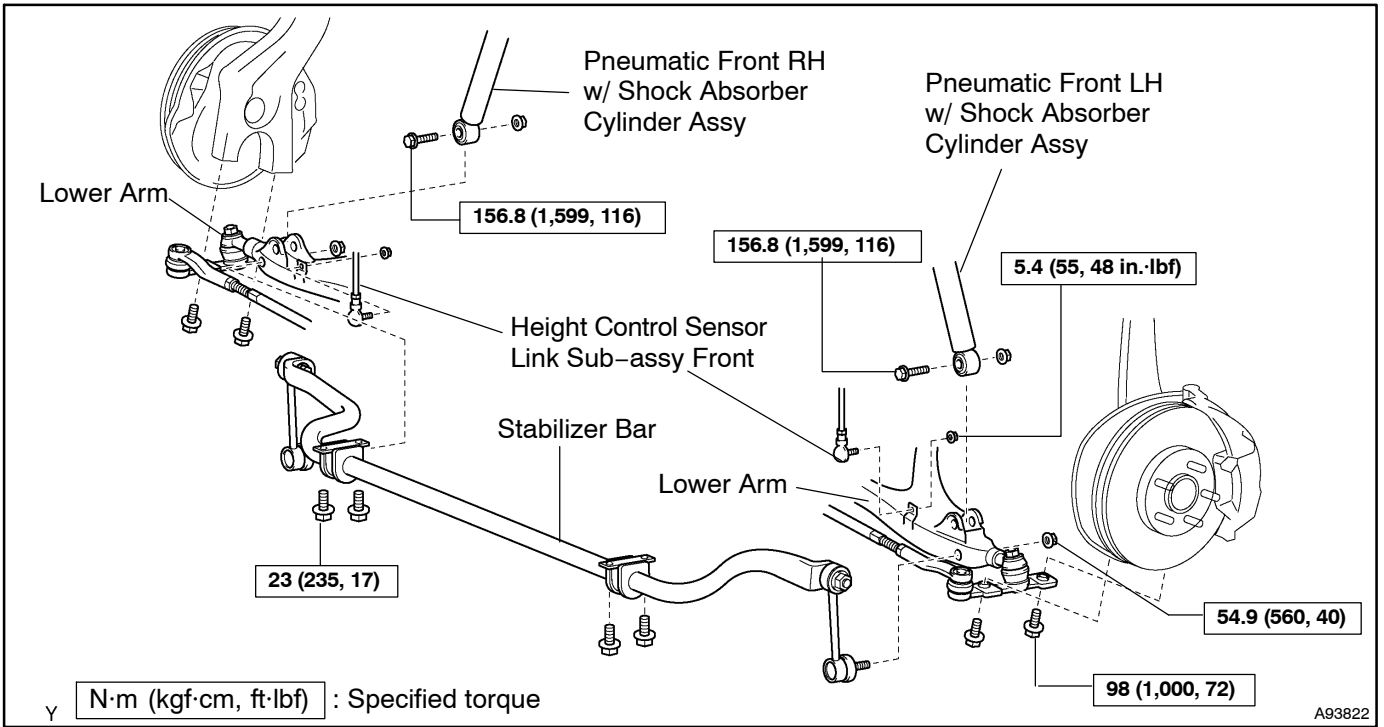

ENGINE MECHANICAL - PARTIAL ENGINE ASSY

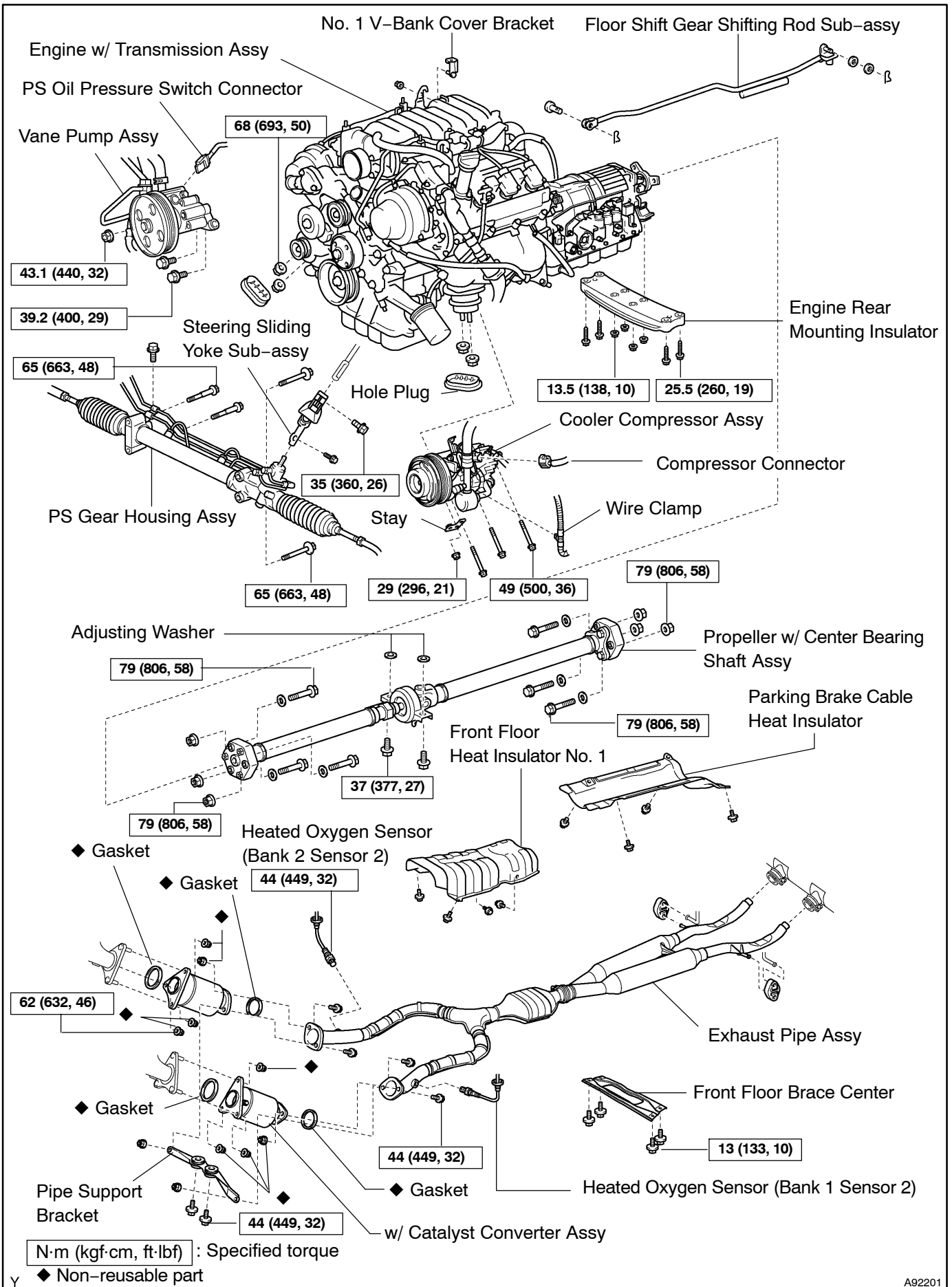

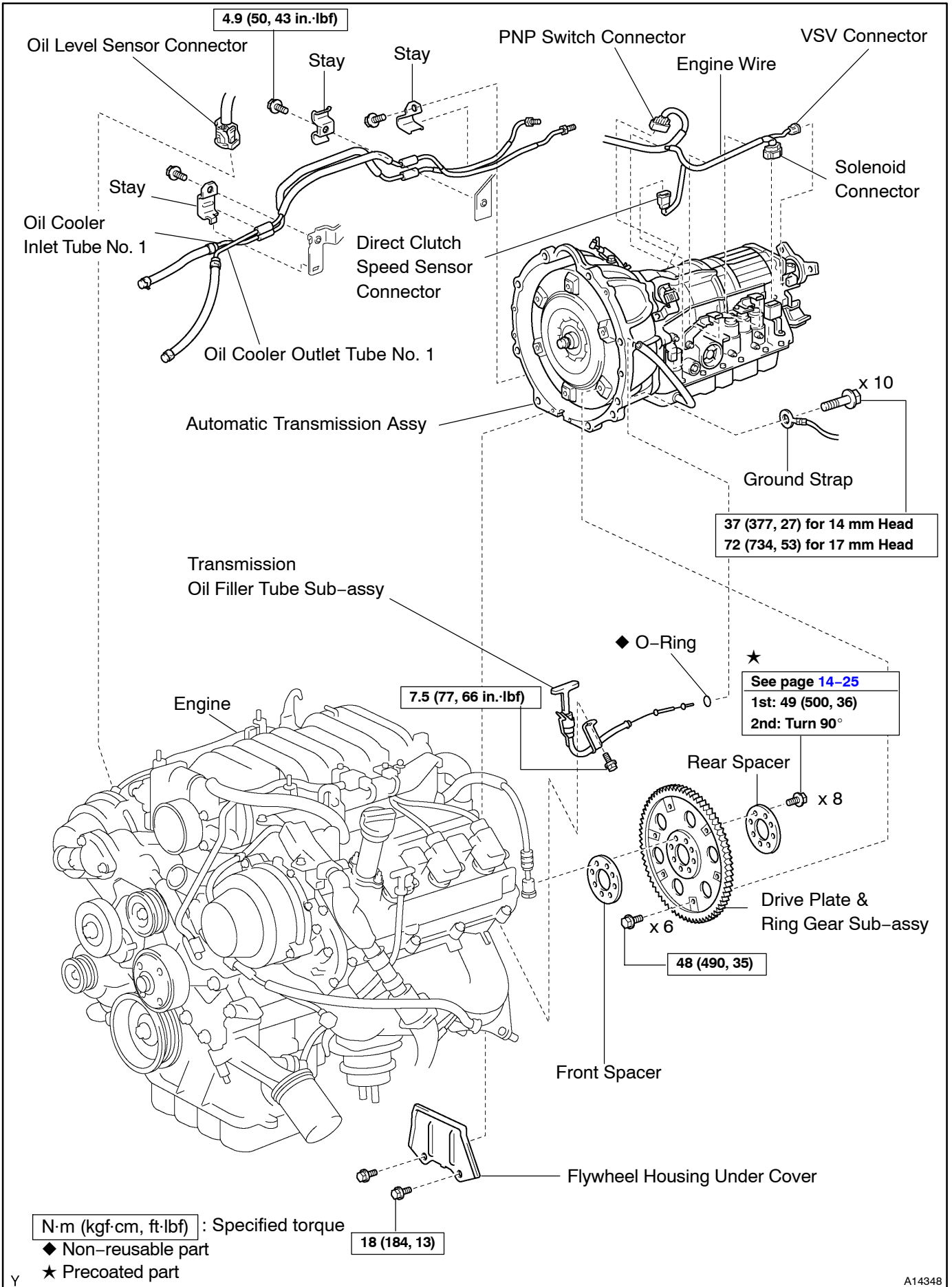

N·m (kgf·cm, ft·lbf) : Specified torque

◆ Non-reusable part

★ Precoated part

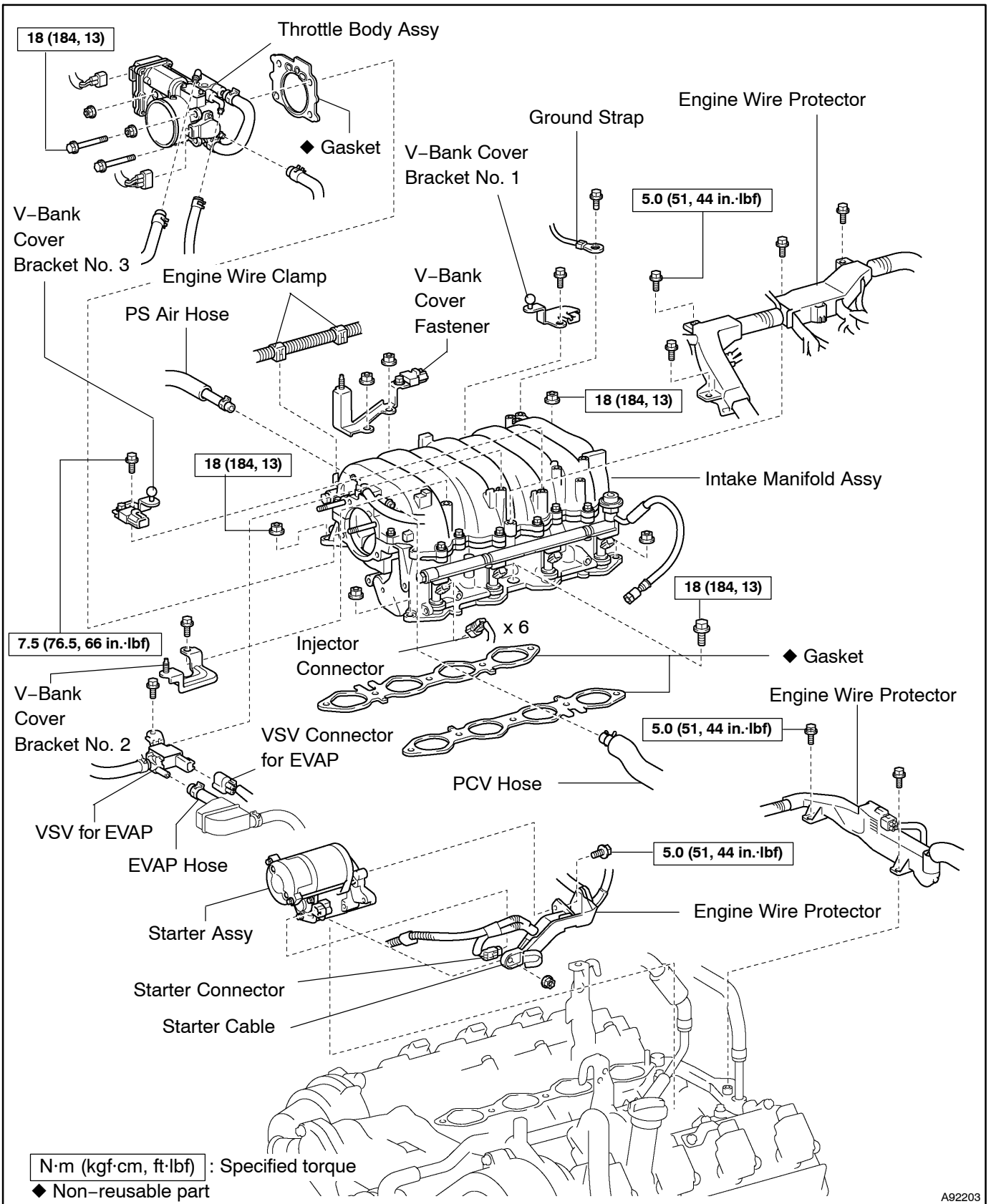

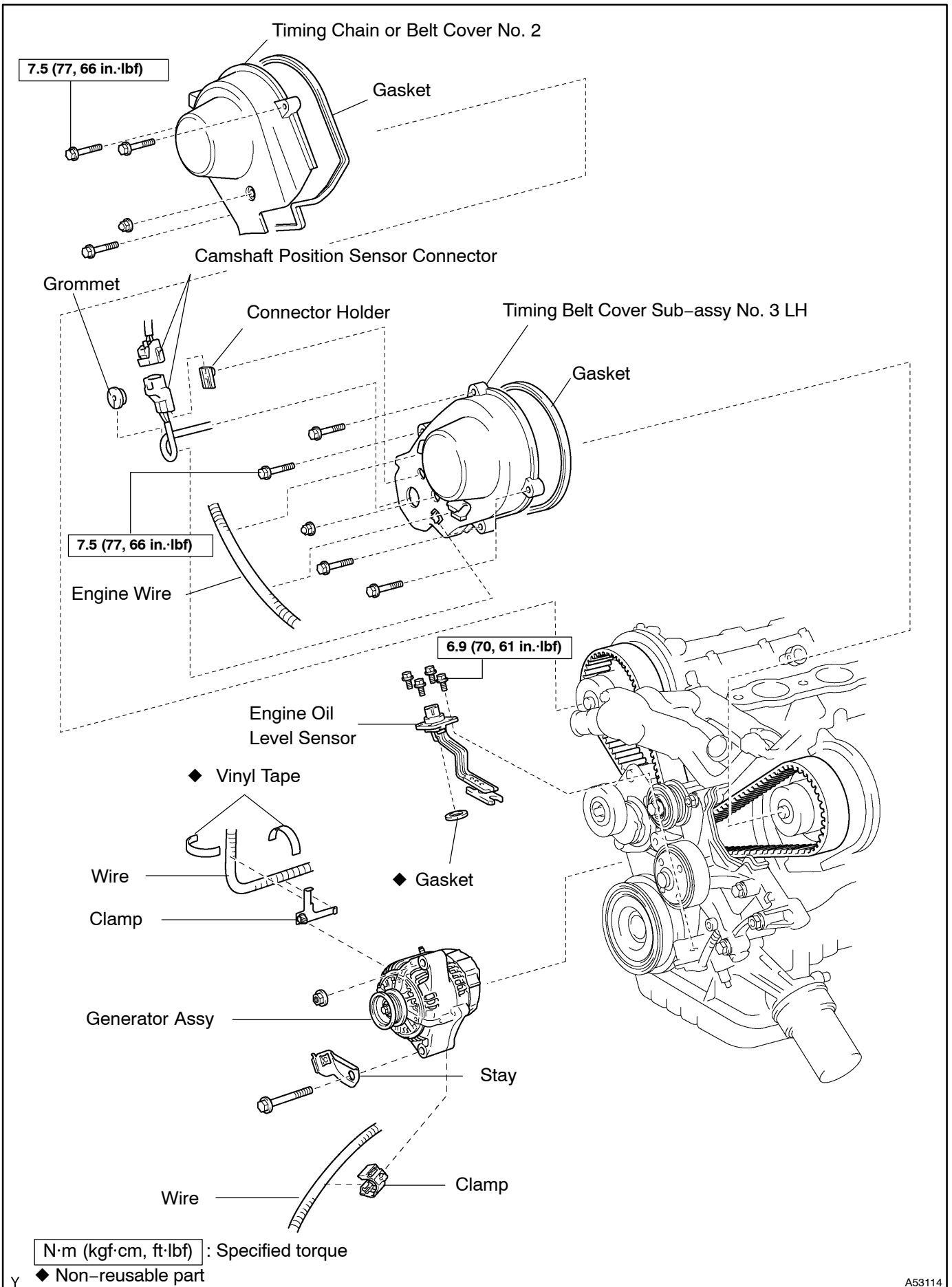

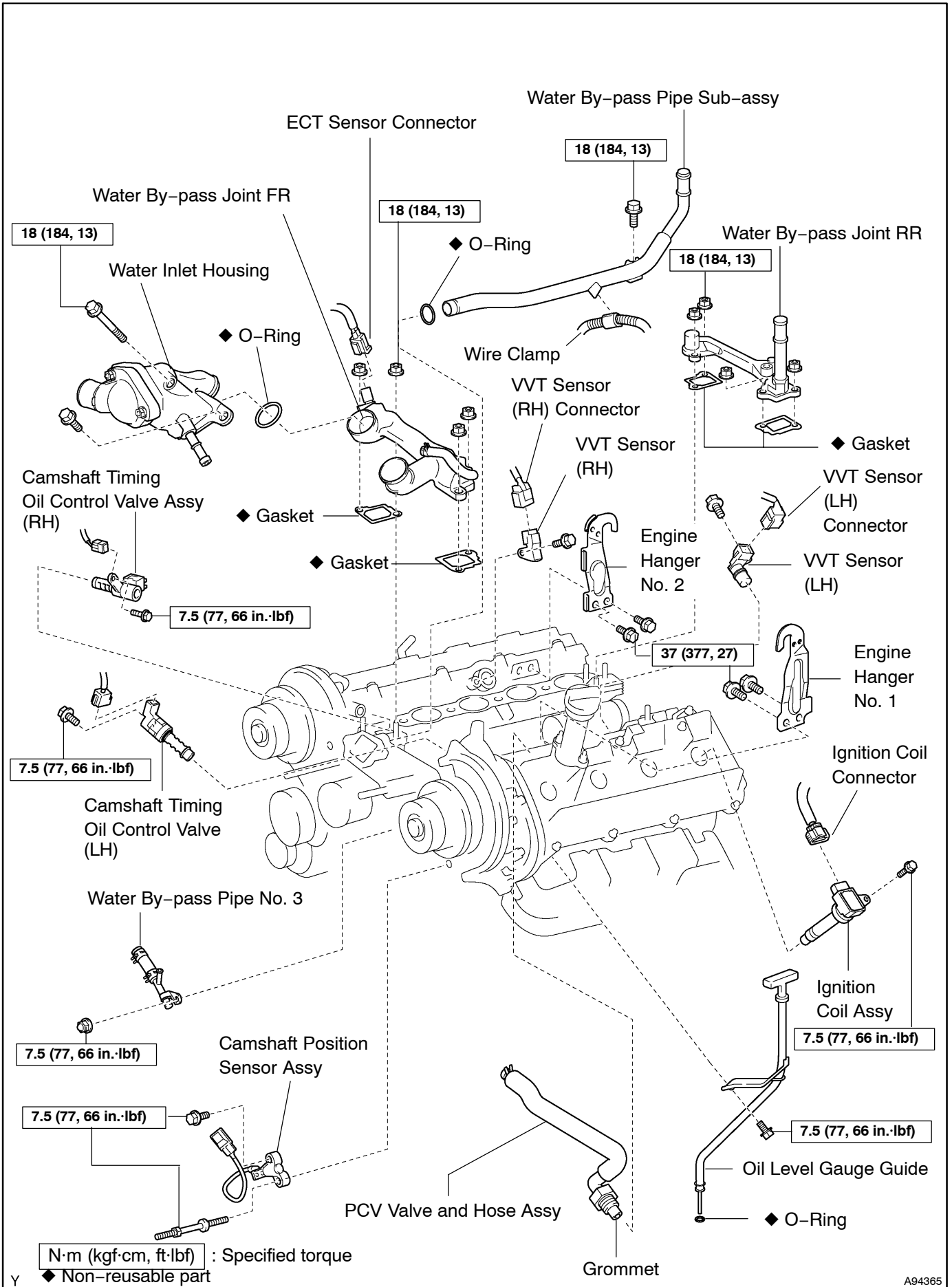



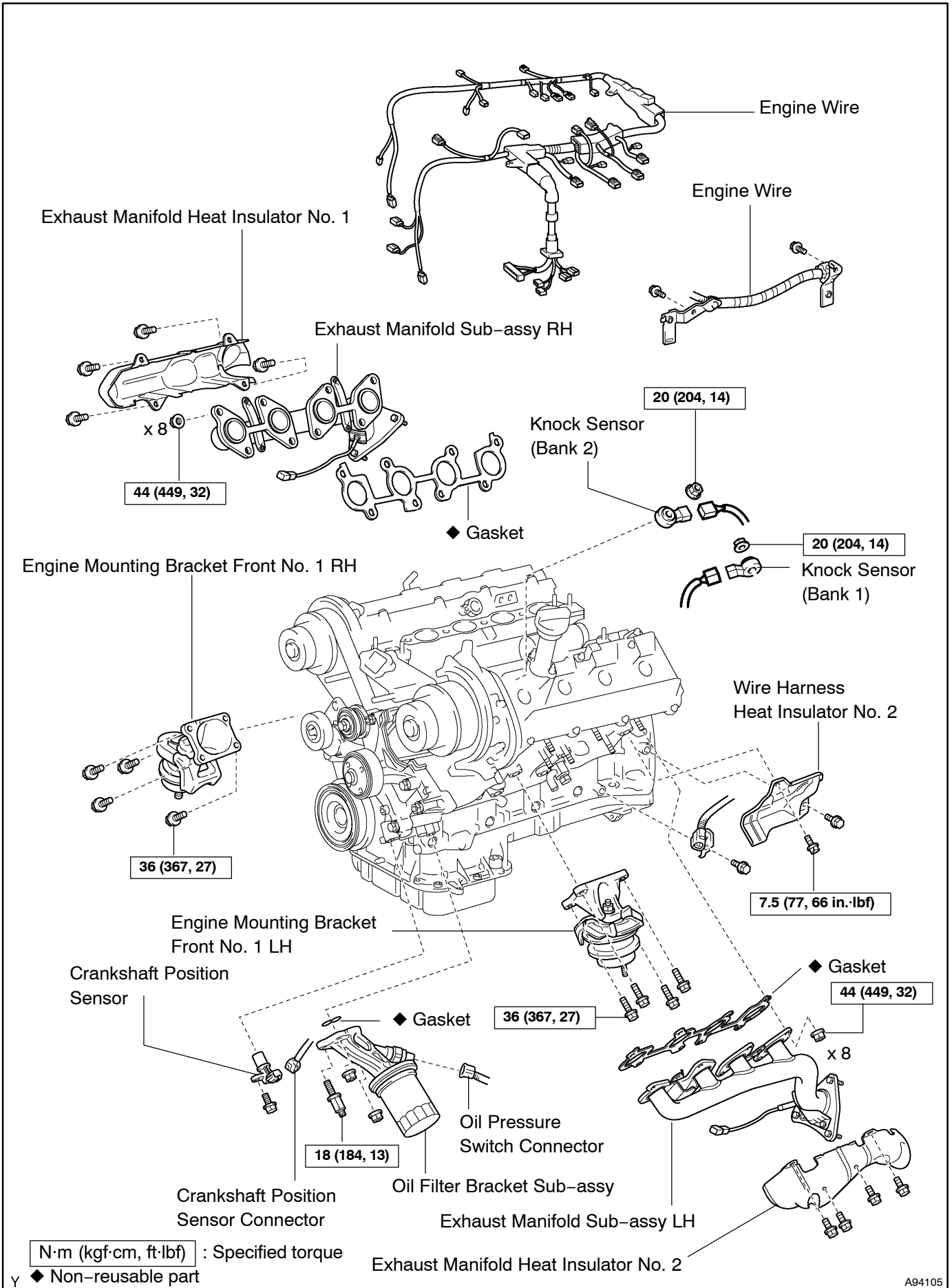

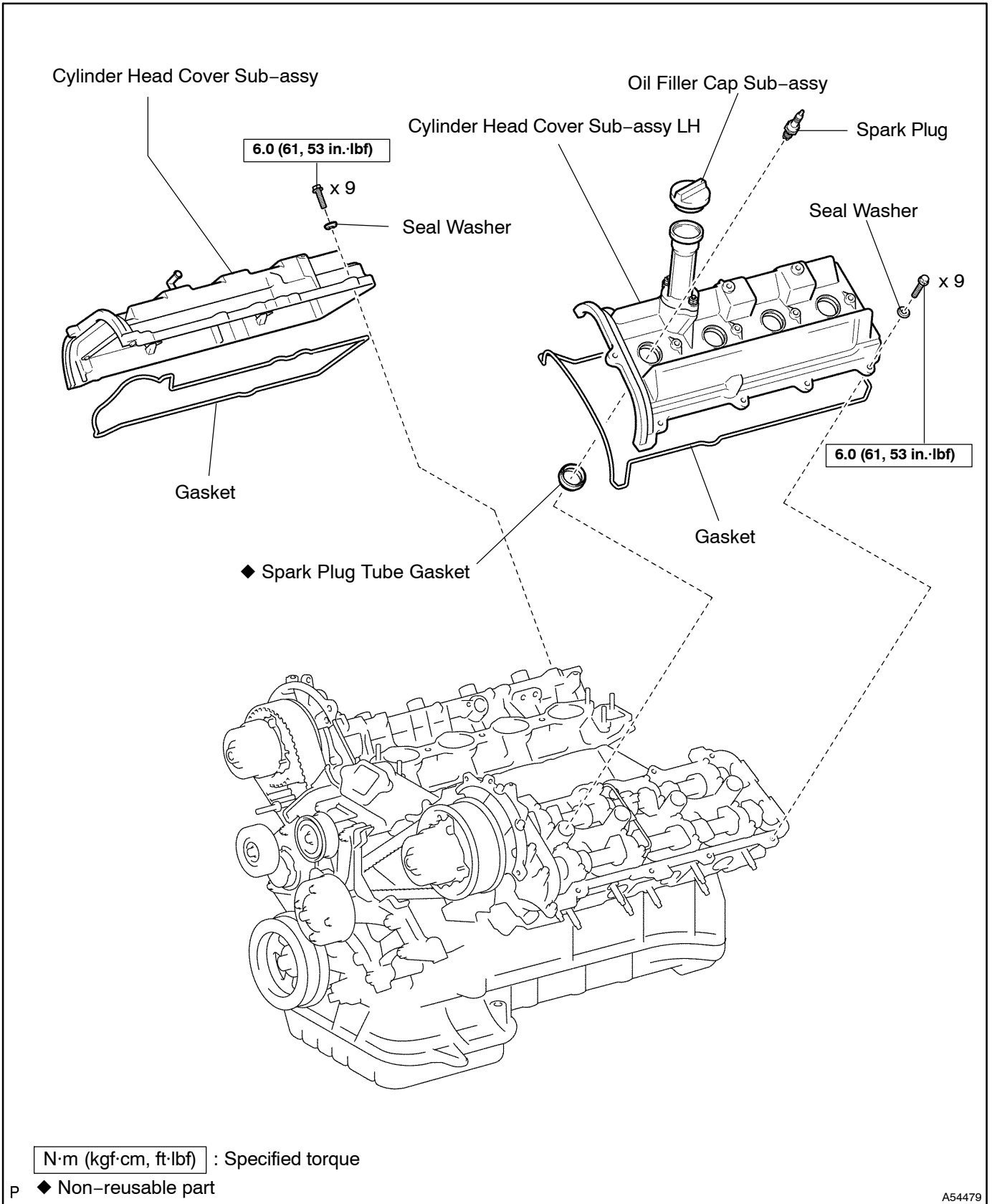

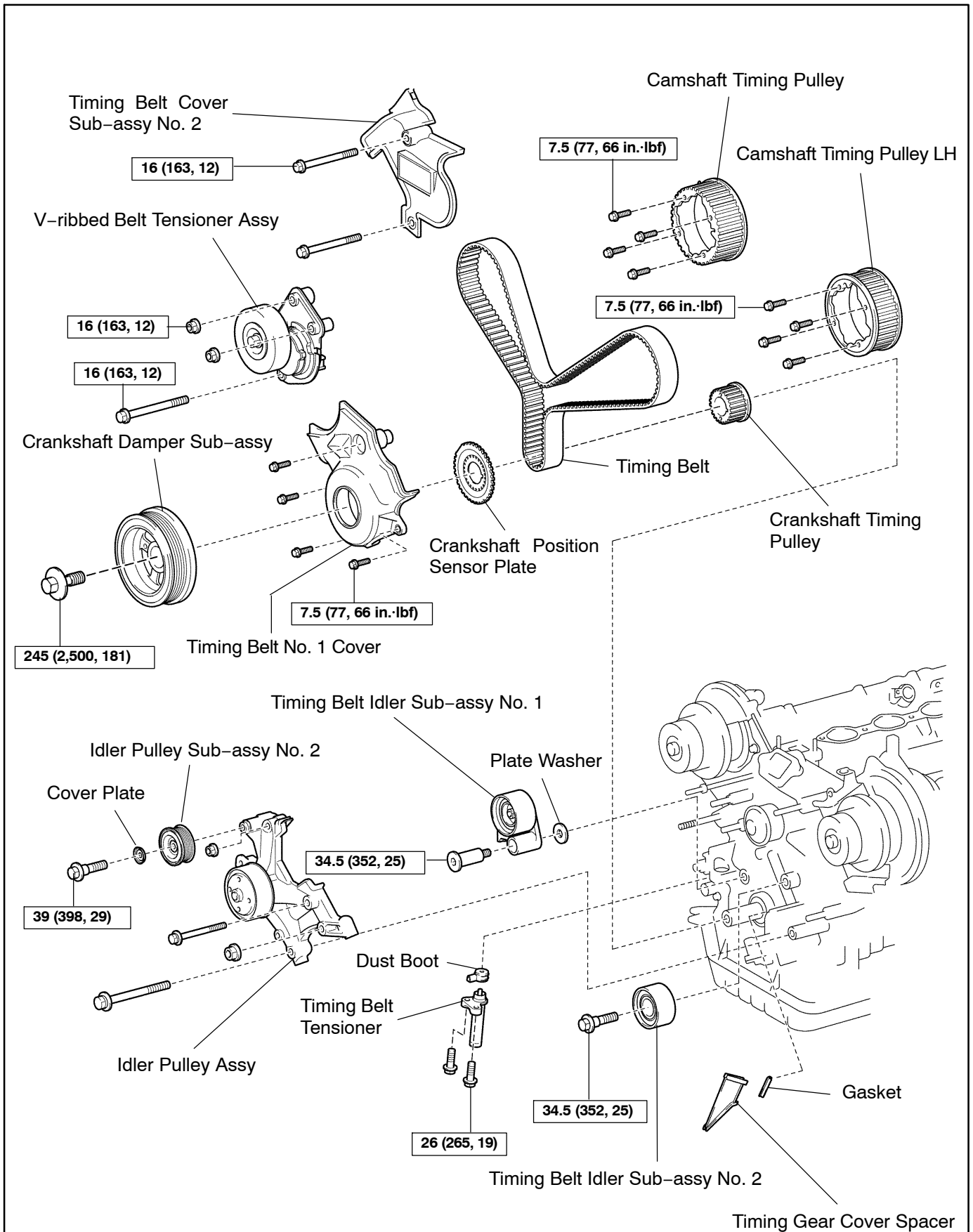

N·m (kgf·cm, ft·lbf) : Specified torque  
 ◆ Non-reusable part

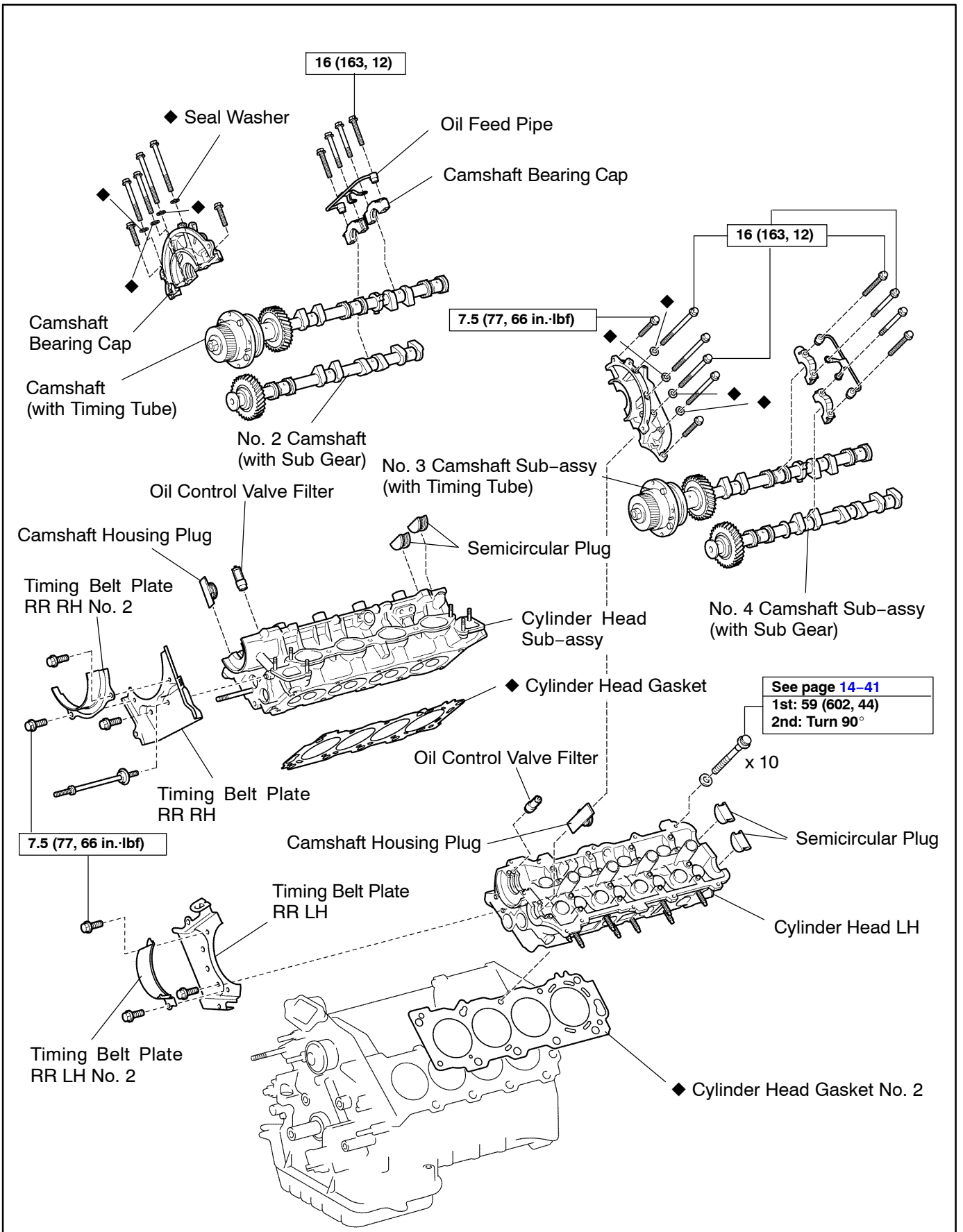

N·m (kgf·cm, ft·lbf) : Specified torque

◆ Non-reusable part

