

PRE-CHECK

1. DESCRIPTION

(a) DIAGNOSIS SYSTEM

When troubleshooting is conducted for Multiplex OBD (M-OBD) vehicles, the only difference from the usual troubleshooting procedure is that the LEXUS hand-held tester is to be connected to read off various data output from the vehicle's skid control ECU.

The skid control ECU records the corresponding DTC when the computer detects a malfunction in the computer itself or its circuit.

To check DTC, connect a LEXUS hand-held tester to DLC3 on the vehicle. The LEXUS hand-held tester enables you to erase DTC and activate the several solenoids and actuators, and check freeze frame data and various forms on skid control data.

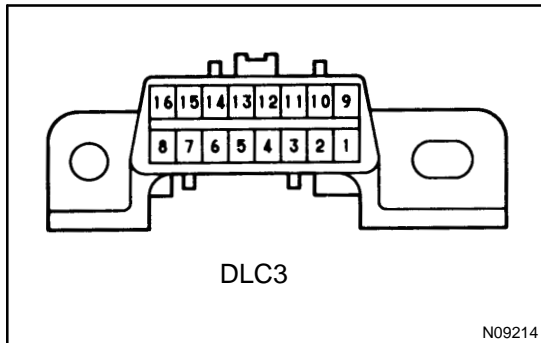

(b) DATA LINK CONNECTOR 3 (DLC3)

The skid control ECU uses ISO 14230 for communication. The terminal arrangement of DLC3 complies with SAE J1962 and matches the ISO 14230 format.

Terminal No.	Connection	Voltage or Resistance	Condition
7	Bus + Line	Pulse generation	During transmission
4	Chassis Ground	↔ Body Ground 1 Ω or less	Always
5	Signal Ground	↔ Body Ground 1 Ω or less	Always
16	Battery Positive	↔ Body Ground 9 - 14 V	Always

HINT:

If the display shows "UNABLE TO CONNECT TO VEHICLE" when the LEXUS hand-held tester cable is connected to DLC3, the ignition switch is turned ON and the LEXUS hand-held tester is operated, there is a problem on the vehicle side or the tester side.

- If communication is normal when the tester is connected to another vehicle, inspect DLC3 on the original vehicle.
- If communication is still not possible when the tester is connected to another vehicle, the problem is probably in the tester itself, so consult the Service Department listed in the tester's Operator's Manual.

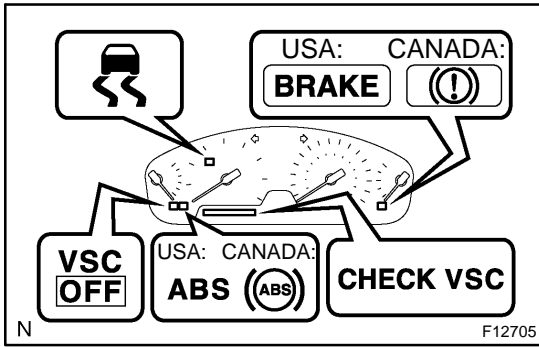

2. ABS WITH EBD & BA & TRAC & VSC SYSTEM: DIAGNOSIS SYSTEM

- (a) Inspect the battery positive voltage.
Battery positive voltage: 10 – 14 V
- (b) Check the warning lights and indicator lights.
 - (1) Release the parking brake pedal.
 - (2) When the ignition switch is ON, check that the ABS warning light, Brake warning light, VSC OFF indicator light and SLIP indicator light go on for 3 sec.

HINT:

- If the ECU stores DTC, "CHECK VSC" is displayed on the multi-information display and ABS warning light and VSC OFF indicator light are ON.
- If the check result is not normal, proceed to troubleshooting for the light circuit.

Trouble Area	See Page
ABS warning light circuit	DI-428
Brake warning light circuit	DI-436
VSC OFF indicator light circuit	DI-431
SLIP indicator light circuit	DI-434

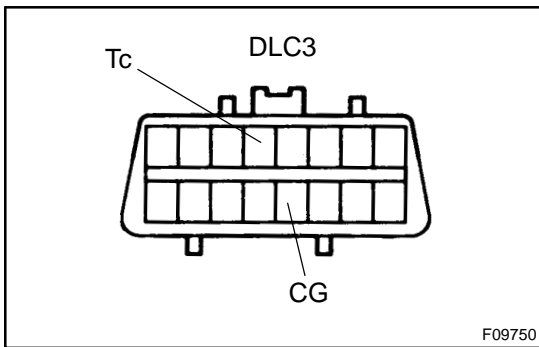

- (c) In case of not using the LEXUS hand-held tester: Check the DTC of ABS system.
 - (1) Using SST, connect terminals Tc and CG of DLC3. SST 09843-18040
 - (2) Turn the ignition switch ON.
 - (3) Read the DTC from the ABS warning light on the combination meter.

HINT:

- If no code appears, inspect the diagnostic circuit, ABS warning light circuit.

Trouble Area	See page
Tc terminal circuit	DI-442
ABS warning light circuit	DI-428

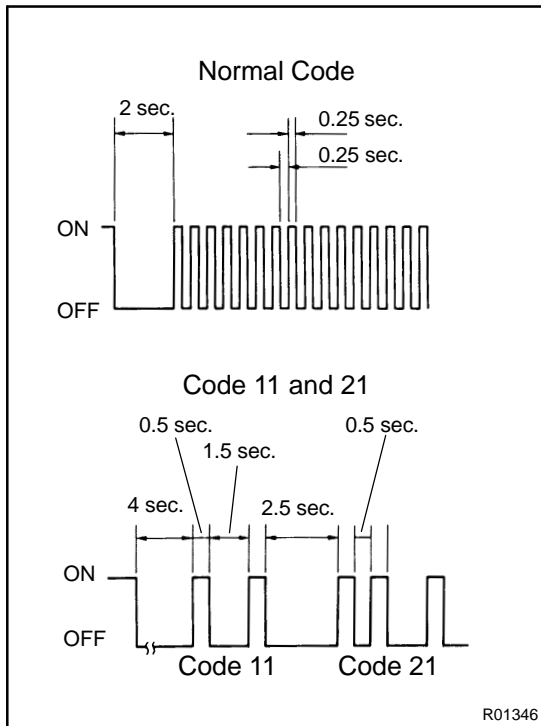

- As an example, the blinking patterns for the normal code and codes 11 and 21 are shown on the left.
 - Codes are examples in the code table on page [DI-350](#).
 - After completing the check, disconnect terminal Tc and CG of DLC3, and turn off the display.
- If 2 or more malfunctions are detected at the same time, the lowest numbered DTC will be displayed 1st.

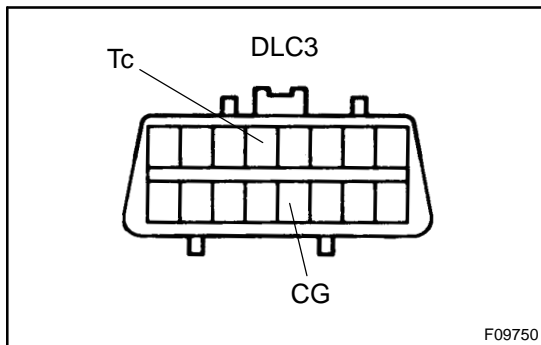

- (d) In case of not using the LEXUS hand-held tester:
Check the DTC of VSC system.
- Using SST, connect terminals Tc and CG of DLC3. SST 09843-18040
 - Turn the ignition switch ON.
 - Read the DTC from the multi-information display on the combination meter.

HINT:

- At this time, "VSC OK", is displayed when VSC system is in normal condition. If any DTC is detected, "VSC 31", for example, will be displayed.
- If there are 2 or more DTC, DTC will be displayed in ascending order of the number.
- If no code appears, inspect the VSC warning indicator circuit and Tc terminal circuit.

Trouble Area	See page
Tc terminal circuit	DI-443
VSC warning indicator circuit	DI-425

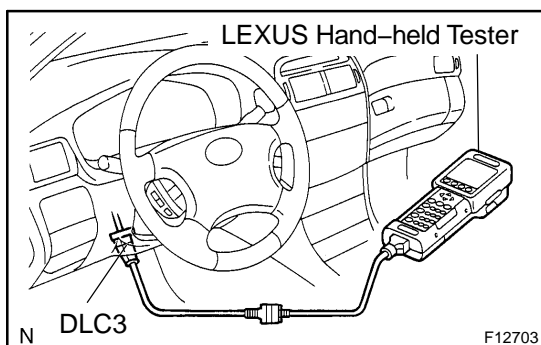

- (e) In case of using the LEXUS hand-held tester:
Check the DTC.
- Hook up the LEXUS hand-held tester to the DLC3.
 - Turn the ignition switch ON.
 - Read the DTC by following the prompts on the tester screen.

HINT:

Please refer to the LEXUS hand-held tester operator's manual for further details.

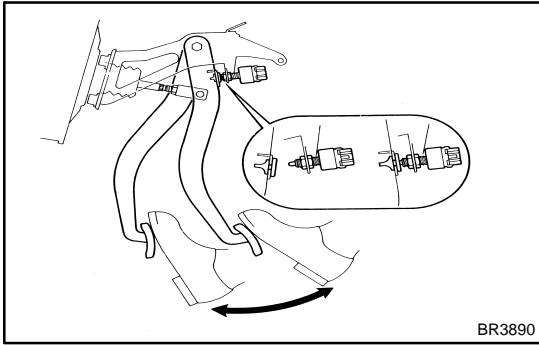

- (f) In case of not using the LEXUS hand-held tester:
Clear the DTC.
- (1) Using SST, connect terminals Tc and CG of DLC3.
SST 09843-18040
 - (2) Turn the ignition switch ON.
 - (3) Clear the DTC stored in ECU by depressing the brake pedal 8 times or more within 5 sec.
 - (4) Check that the ABS warning light show the normal code and "CHECK VSC" is not displayed on the multi-information display.
 - (5) Remove the SST from the terminals of DLC3.
SST 09843-18040

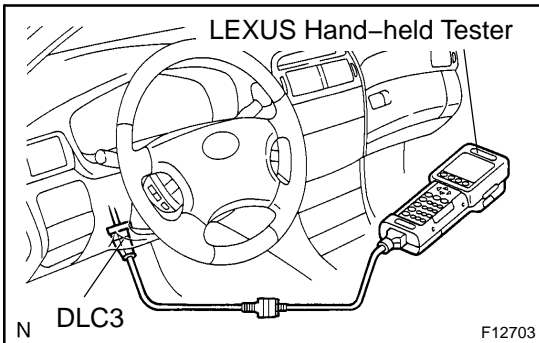

- (g) In case of using the LEXUS hand-held tester:
Clear the DTC.
- (1) Hook up the LEXUS hand-held tester to the DLC3.
 - (2) Turn the ignition switch ON.
 - (3) Operate the LEXUS hand-held tester to erase the codes.

HINT:

Please refer to the LEXUS hand-held tester operator's manual for further details.

**3. In case of not using the LEXUS hand-held tester:
ABS SENSOR SIGNAL CHECK (TEST MODE)**

NOTICE:

When having replaced the yaw rate sensor, deceleration sensor and/or ECU, perform zero point calibration of the yaw rate and deceleration sensors (See step 7.).

HINT:

If the ignition switch is turned from ON to ACC or LOCK during test mode, DTC will be erased.

- (a) Procedures for test mode:
- (1) Turn the ignition switch OFF.
 - (2) Using SST, connect terminals Ts and CG of DLC3.
SST 09846-18040
 - (3) Check that the steering wheel is in the straight-ahead position.
 - (4) Turn the ignition switch ON.
 - (5) Check that the ABS warning light blinks.

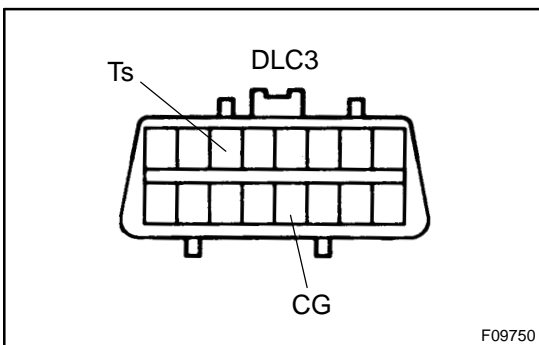

HINT:

If the ABS warning light does not blink, inspect the ABS warning light circuit or Ts terminal circuit.

Trouble Area	See page
Ts terminal circuit	DI-445
ABS warning light circuit	DI-429

- (b) Check the brake pedal load sensing switch.
- (1) By pumping the brake pedal, release the booster vacuum.
 - (2) Turn the ignition switch to ON (do not start the engine) and keep depressing the brake pedal for 1 sec. or more with a force of approx. 59 N (6 kgf, 14 lbf) or more.
 - (3) Check that the brake warning light is lit and the operating sound of the ABS motor is heard.
 - (4) Start the engine and depress the brake pedal with a force of approx. 59 N (6 kgf, 14 lbf) or more.
 - (5) Check that the brake warning light goes out.

HINT:

When rechecking, once exit the test mode and then activate the test mode again.

- (c) Check the deceleration sensor.
Keep the vehicle in a stationary condition on a level place for 1 sec. or more.
- (d) Check the master cylinder pressure sensor.
- (1) Leaving the vehicle in a stationary condition and the brake pedal in free condition for 1 sec. or more, continue to depress the brake pedal with a force of 98 N (10 kgf, 22 lbf) or more for 1 sec. or more.
 - (2) While the vehicle is stopped, release the brake pedal.
 - (3) While the vehicle is stopped, quickly depress the brake pedal once or more and check the ABS warning light is lit for 3 sec.

HINT:

Repeat the operation until the ABS warning light is lit.

- (e) Check the speed sensor signal.
Drive the vehicle straightforward.
Drive the vehicle with the speed faster than 45 km/h (28 mph) for several seconds and check that the ABS warning light comes off.

HINT:

The sensor check may not be completed if the wheels spin or the steering wheel is steered during this check.

- (f) Stop the vehicle.

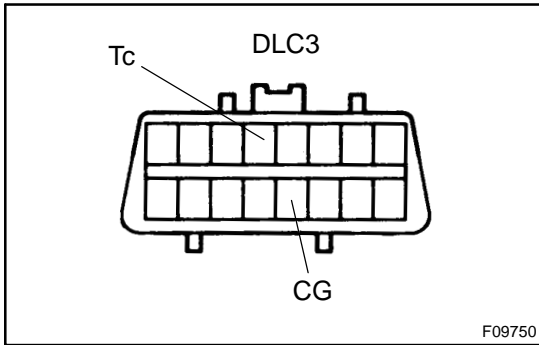

- (g) Using SST, connect terminals Tc and CG of DLC3.
SST 09843-18040
 - (h) Read the number of blinks of the ABS warning light.
- HINT:
- See the list of DTC on the next page.
 - If every sensor is normal, the normal code is output (A cycle of 0.25 sec. ON and 0.25 sec. OFF is repeated).
 - If 2 or more malfunctions are detected at the same time, the lowest numbered will be displayed 1st.

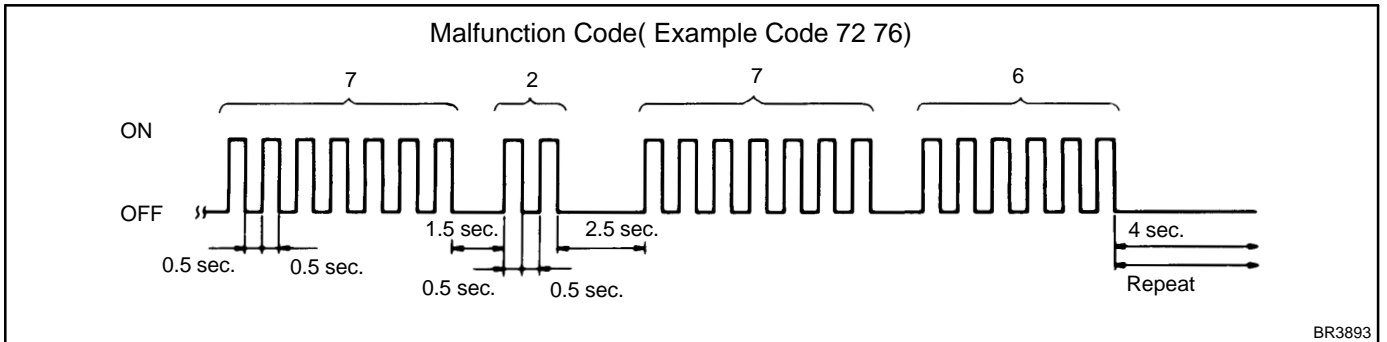

- (i) After doing the check, disconnect the SST from terminals Ts and CG, Tc and CG of DLC3 and turn the ignition switch OFF.
SST 09843-18040

**4. In case of using the LEXUS hand-held tester:
ABS SENSOR SIGNAL CHECK (TEST MODE)**

NOTICE:

When having replaced the yaw rate sensor, deceleration sensor and/or ECU, perform zero point calibration of the yaw rate and deceleration sensors (See step 7.). Make sure that this operation should be done before starting the following.

HINT:

If the ignition switch is turned from ON to ACC or LOCK during test mode, DTC will be erased.

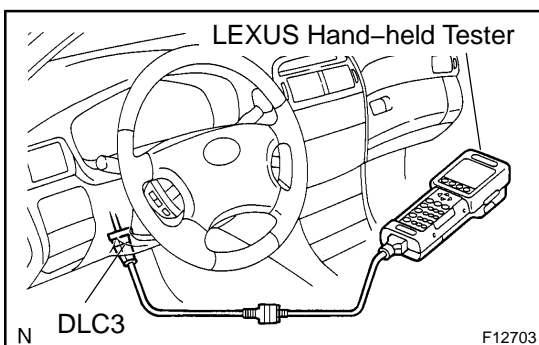

- (a) Hook up the LEXUS hand-held tester to the DLC3.
- (b) Do steps 3.-(a)-(3) to (5) and from (b) to (f) on the previous pages.
- (c) Read the DTC by following the prompts on the tester screen.

HINT:

Please refer to the LEXUS hand-held tester operator's manual for further details.

DTC of ABS sensor check function:

Code No.	Diagnosis	Trouble Area
C1271 / 71	Low output voltage of right front speed sensor	<ul style="list-style-type: none"> • Right front speed sensor • Sensor installation • Sensor rotor
C1272 / 72	Low output voltage of left front speed sensor	<ul style="list-style-type: none"> • Left front speed sensor • Sensor installation • Sensor rotor
C1273 / 73	Low output voltage of right rear speed sensor	<ul style="list-style-type: none"> • Right rear speed sensor • Sensor installation • Sensor rotor
C1274 / 74	Low output voltage of left rear speed sensor	<ul style="list-style-type: none"> • Left rear speed sensor • Sensor installation • Sensor rotor
C1275 / 75	Abnormal change in output voltage of right front speed sensor	Right front speed sensor rotor
C1276 / 76	Abnormal change in output voltage of Left front speed sensor	Left front speed sensor rotor
C1277 / 77	Abnormal change in output voltage of right rear speed sensor	Right rear speed sensor rotor
C1278 / 78	Abnormal change in output voltage of Left rear speed sensor	Left rear speed sensor rotor
C1279 / 79	Deceleration sensor is faulty	<ul style="list-style-type: none"> • Deceleration sensor • Sensor installation
C1281 / 81	Master cylinder pressure sensor output signal is faulty	Master cylinder pressure sensor

**5. In case of not using the LEXUS hand-held tester:
VSC SENSOR SIGNAL CHECK (TEST MODE)**

NOTICE:

When having replaced the yaw rate sensor, deceleration sensor and/or ECU, perform zero point calibration of the yaw rate and deceleration sensors (See step 7.).

HINT:

If the ignition switch is turned from ON to ACC or LOCK during test mode, DTC will be erased.

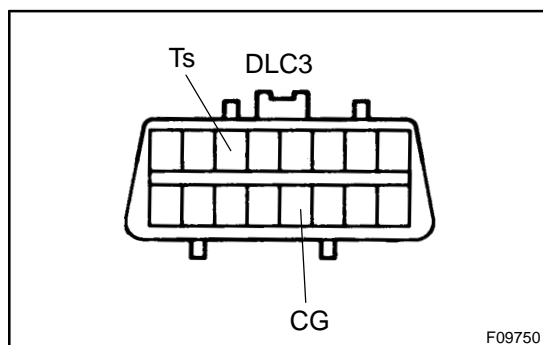

(a) Procedures for test mode:

- (1) Turn the ignition switch OFF.
- (2) Check that the shift lever position is at P range. Turn the steering wheel to the straight-ahead position.
- (3) Using SST, connect terminals Ts and CG of DLC3.
SST 09843-18040

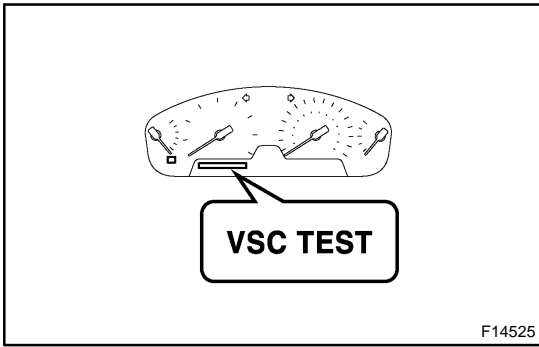

- (4) Start the engine and check that "VSC TEST" is displayed on the multi-information display.

HINT:

If the "VSC TEST" does not displayed, inspect the VSC warning indicator circuit and Ts terminal circuit.

Trouble Area	See page
Ts terminal circuit	DI-445
VSC warning indicator circuit	DI-425

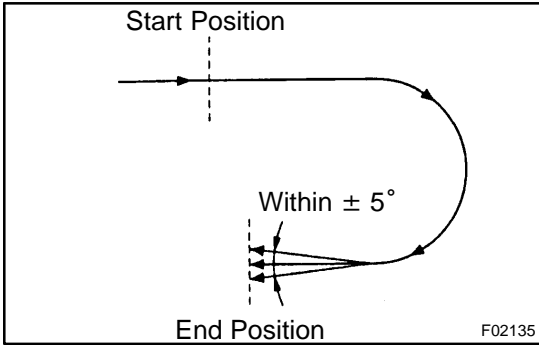

- (b) Check the yaw rate sensor.
Shift the shift lever to the D range and drive the vehicle at the vehicle speed of approx. 5 km/h (3 mph). Turn the steering wheel either to left or right for 90° or more, and maintain 180° circular drive for the vehicle.

Stop the vehicle and shift the shift lever to the P range. Check that the VSC warning buzzer sounds for 3 sec.

If the VSC warning buzzer sounds, the sensor check is in normal completion.

If the VSC warning buzzer does not sound, check the VSC warning buzzer circuit, then do the sensor check again.

Trouble Area	See page
VSC warning buzzer circuit	DI-440

If the VSC warning buzzer still does not sound, there is malfunction in the VSC sensor, so check the DTC.

HINT:

- Drive the vehicle circularly by 180°. At the end of the turn, the direction of the vehicle should be within 180° ± 5° from its start position.
- Do not spin the wheels.

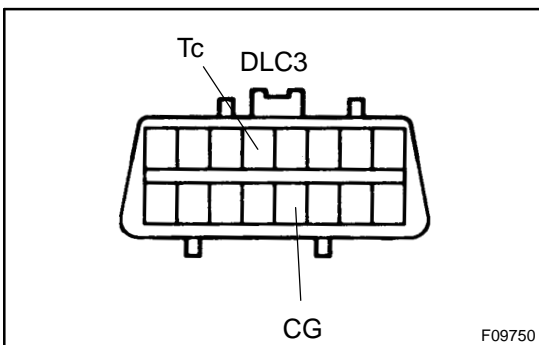

- (c) Read the DTC.
(1) Using SST, connect terminals Tc and CG of DLC3.
SST 09843-18040

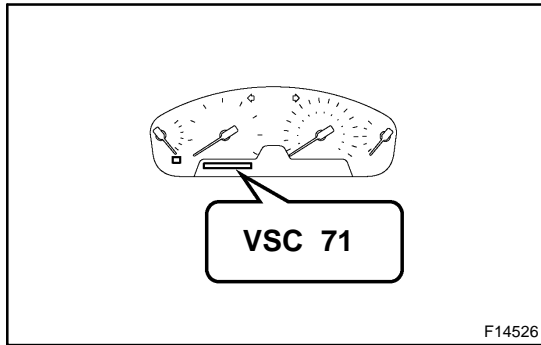

- (2) Read the number of displays on the multi-information display.

HINT:

See the list of DTC shown on the next page.

- (3) After doing the check, disconnect the SST from terminals Ts and CG, Tc and CG of DLC3 and turn the ignition switch OFF.

SST 09843-18040

6. In case of using the LEXUS hand-held tester: VSC SENSOR SIGNAL CHECK (TEST MODE)

NOTICE:

When having replaced the yaw rate sensor, deceleration sensor and/or ECU, perform zero point calibration of the yaw rate and deceleration sensors (See step 7.). Make sure that this operation should be done before starting the following.

HINT:

If the ignition switch is turned from ON to ACC or LOCK during test mode, DTC will be erased.

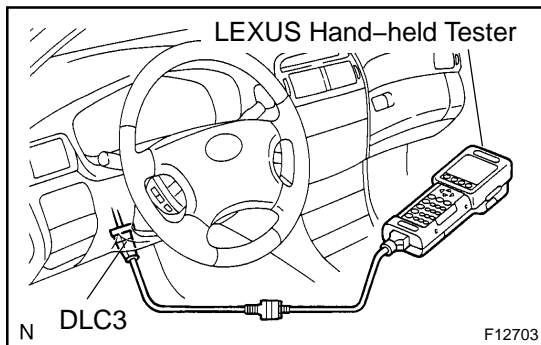

- (a) Hook up the LEXUS hand-held tester to the DLC3.
- (b) Do steps 5.-(a)-(2), (a)-(4), (b) and (c) on the previous pages.
- (c) Read the DTC by following the prompts on the tester screen.

HINT:

Please refer to the LEXUS hand-held tester operator's manual for further details.

DTC of VSC sensor check function:

Code No.	Diagnosis	Trouble Area
C0371 / 71	Yaw rate sensor output signal malfunction	<ul style="list-style-type: none"> • Yaw rate sensor • Yaw rate sensor circuit

7. IF NECESSARY, PERFORM ZERO POINT CALIBRATION OF YAW RATE AND DECELERATION SENSORS

HINT:

- When having replaced the yaw rate sensor, deceleration sensor or the ECU, make sure to perform yaw rate and deceleration sensors' zero point calibration. Be sure to complete this step 7. once it is started.
- During step 7., a not-replaced sensor also requires zero point calibration.

NOTICE:

- **While obtaining the zero point, do not give any vibration to the vehicle by tilting, moving or shaking it and keep it in a stationary condition. (Do not start the engine.)**
- **Be sure to do this on a level surface (within an inclination of 1 %).**

- (a) Clear the zero points of the yaw rate and deceleration sensors.
- (1) Shift the shift lever to P range.
 - (2) Turn the ignition switch ON in a stationary condition.

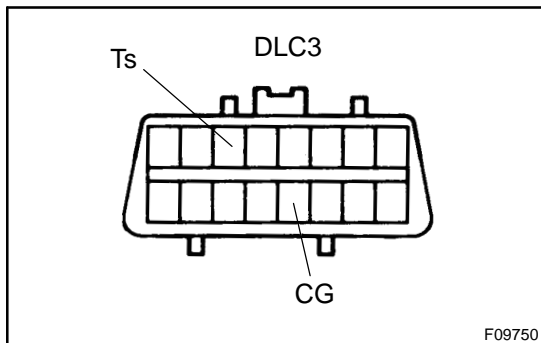

- (3) With the lit switch ON, using SST, repeat a cycle of short and open between terminals Ts and CG of DLC3 4 times or more within 8 sec. Check that the VSC OFF indicator light is lit indicating the recorded zero point is erased.

SST 09843-18040

- (4) Turn the ignition switch OFF.
- (b) Obtain zero point of the yaw rate sensor.
- (1) Make the terminals Ts and CG of DLC3 disconnected.
 - (2) Turn the ignition switch ON.

HINT:

The vehicle should be in a stationary condition with the shift lever in P range.

- (3) Check that the lit VSC OFF indicator light goes off about 15 sec. after the ignition switch is turned ON.

HINT:

Even if the ignition is not turned OFF in step (a)–(4) and remains ON, the yaw rate sensor zero point calibration can be completed. In this case, the VSC OFF indicator light is lit for about 15 sec. and then starts blinking. (Normal code)

- (4) After ensuring that the VSC OFF indicator light remains OFF for 2 sec., turn the ignition switch OFF.

HINT:

If the ignition switch is not turned OFF in step (a)–(4), make sure that the VSC OFF indicator light blinks for 2 sec. Then turn the ignition switch OFF.

(c) Perform deceleration sensor zero point calibration.

NOTICE:

After step (b) (the yaw rate sensor zero point calibration), the VSC warning light goes off. At this time, if the vehicle is driven without performing step (c) (deceleration sensor zero point calibration), deceleration sensor zero point calibration malfunction will be detected and the VSC warning light will light up. Therefore, perform step (c) right after step (b).

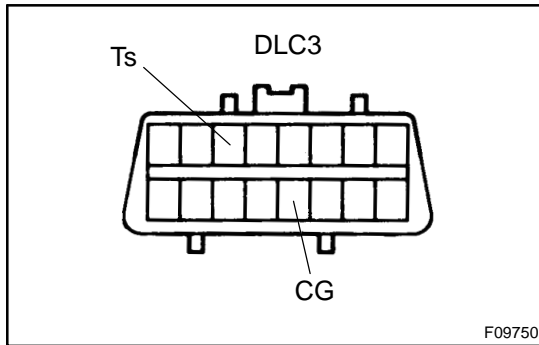

(1) Using SST, connect the terminals Ts and CG of DLC3.

SST 09843-18040

(2) Turn the ignition switch ON.

HINT:

Place the vehicle in a stationary condition with the shift lever in P range.

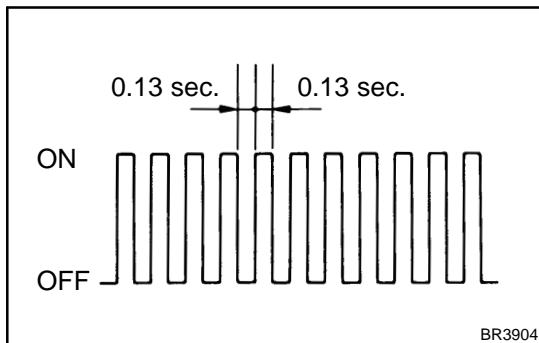

(3) After turning the ignition switch ON, check that the VSC warning light is lit for about 4 sec. and then starts quick blinking at 0.13 sec. intervals.

(4) After ensuring the blinking of the VSC OFF indicator light for 2 sec., turn the ignition switch OFF.

(5) Remove the SST and make the terminals Ts and CG of DLC3 disconnected.

SST 09843-18040

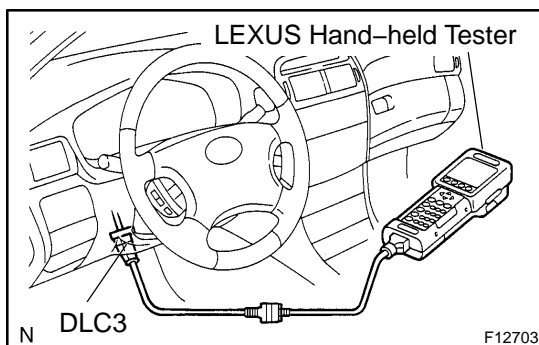
**8. PROGRESSIVE POWER STEERING:
DIAGNOSIS SYSTEM**

(a) Inspect the battery positive voltage.

Battery positive voltage: 10 – 14 V

(b) Check the DTC.

(1) Hook up the LEXUS hand-held tester to the DLC3.

(2) Turn the ignition switch ON.

(3) Read the DTC by following the prompts on the tester screen.

HINT:

Please refer to the LEXUS hand-held tester operator's manual for further details.

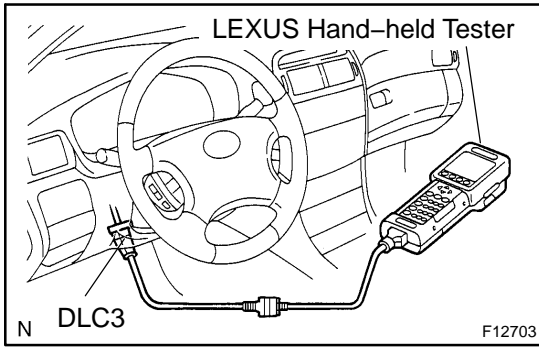

- (c) Clear the DTC.
- (1) Hook up the LEXUS hand-held tester to the DLC3.
 - (2) Turn the ignition switch ON.
 - (3) Operate the LEXUS hand-held tester to erase the codes.

HINT:

Please refer to the LEXUS hand-held tester operator's manual for further details.