

OVERHAUL

HINT:

- The installation procedures are the removal procedures in reverse order. However, only installation procedures requiring additional information are included.
- Use the same procedures for the RH side and LH side.
- The procedures listed below are for the LH side.
- A bolt without a torque specification is shown in the standard bolt chart (see page 03-2).

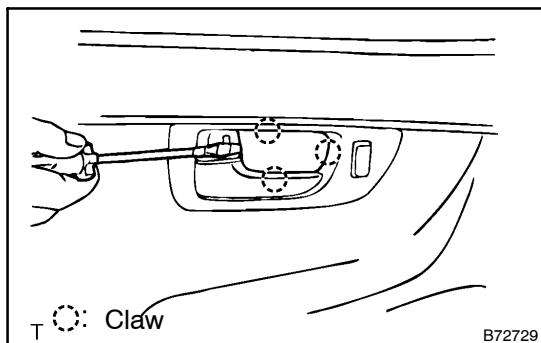

1. REMOVE REAR DOOR INSIDE HANDLE BEZEL LH

- (a) Using a screwdriver, disengage the 3 claws and remove the bezel.

HINT:

Tape the screwdriver tip before use.

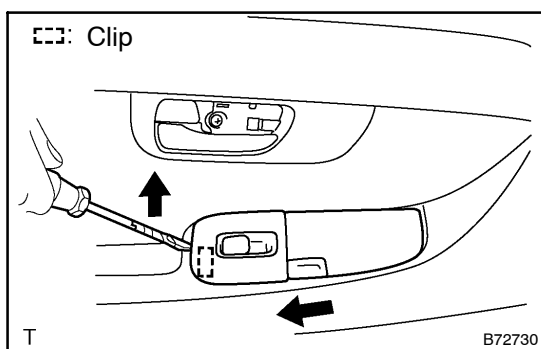

2. REMOVE REAR DOOR ARMREST BASE PANEL UPPER

- (a) Using a screwdriver, pry the armrest panel assembly.

HINT:

Tape the screwdriver tip before use.

- (b) Using a screwdriver, disengage the 2 claws and remove the window control switch from the armrest panel assembly.

HINT:

Tape the screwdriver tip before use.

- (c) Disconnect the connector and ash receptacle light, and remove the armrest base panel assembly.

- (d) Remove the 2 screws and armrest base panel lower from the armrest base panel upper.

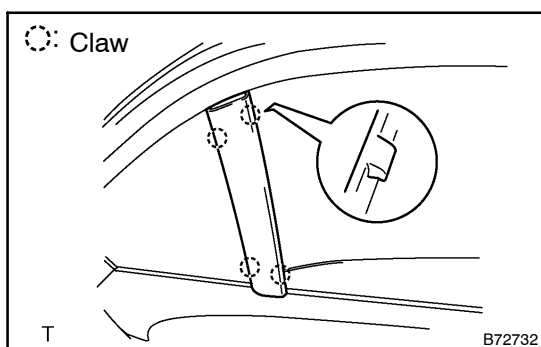

3. REMOVE SIDE TRIM BOARD COVER FRONT LH

- (a) Using a screwdriver, disengage the 4 claws and remove the cover.

HINT:

Tape the screwdriver tip before use.

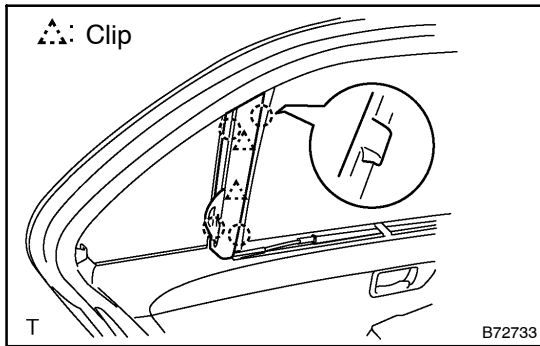

4. w/ Rear side curtain:

REMOVE SIDE REAR CURTAIN ASSY LH

- (a) Using a screwdriver, disengage the 4 claws and 2 clips, remove the curtain.

HINT:

Tape the screwdriver tip before use.

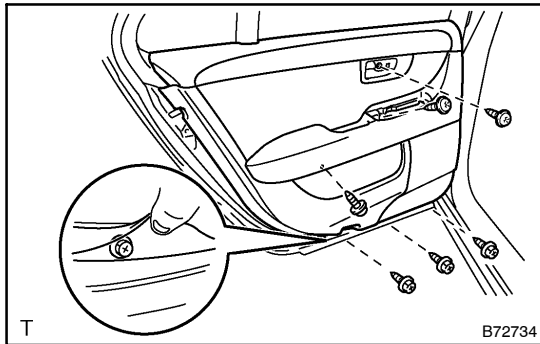

5. **REMOVE REAR DOOR TRIM BOARD SUB-ASSY LH**

- (a) Remove the 6 screws as shown in the illustration.

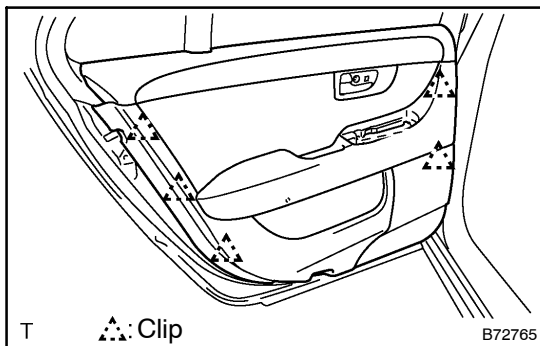

- (b) Using a screwdriver, disengage the 5 clips and remove the trim.

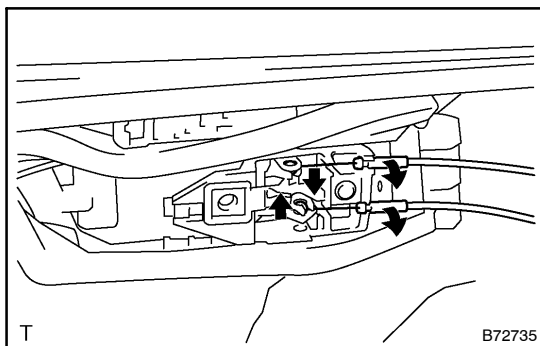

- (c) Disconnect the 2 cables from the inside handle.

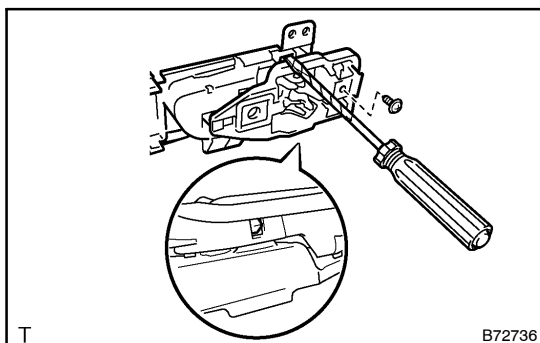

- (d) Remove the screw.

- (e) Using a screwdriver, disengage the 2 claws and remove the inside door handle.

HINT:

Tape the screwdriver tip before use.

- (f) Remove the No. 1 illumination lamp.

- (g) w/ Seat memory:

Remove the seat memory switch.

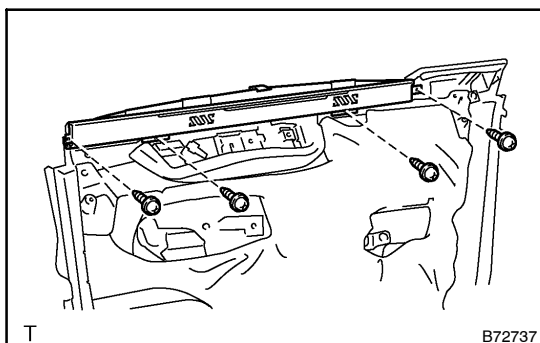

- (h) w/ Rear side curtain:
Remove the 4 screws and curtain.

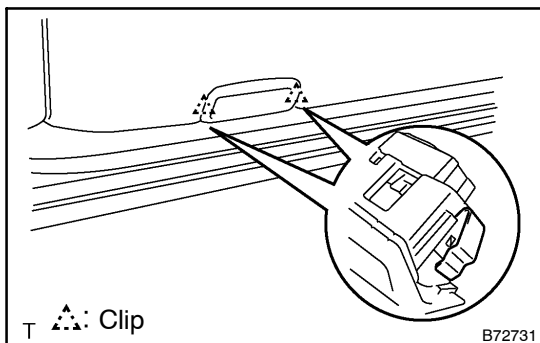

- (i) Using a screwdriver, disengage the 2 clips and remove the courtesy lamp.

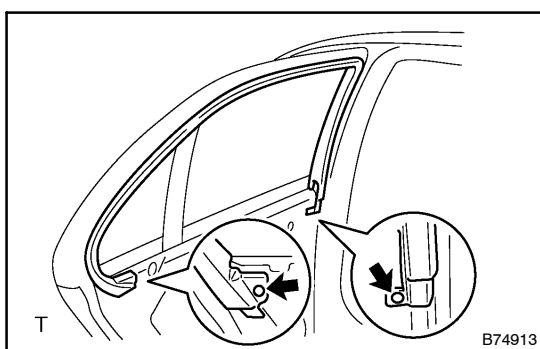

- 6. REMOVE REAR DOOR FRAME GARNISH LH**
(a) Remove the 2 clips and garnish.

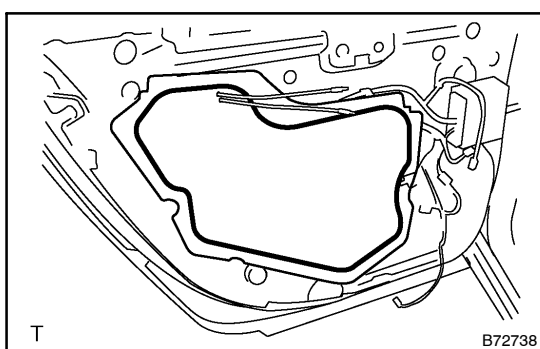

- 7. REMOVE REAR DOOR SERVICE HOLE COVER LH**
(a) Remove the 2 screws and door electrical key oscillator.
(b) Remove the service hole cover.

NOTICE:

Remove the remaining tape on the door side.

8. REMOVE REAR DOOR ECU

- (a) Remove the 2 screws and ECU.

9. REMOVE REAR SPEAKER ASSY NO.2 (See page 67-21)

10. REMOVE REAR SPEAKER ASSY (See page 67-19)

11. REMOVE REAR DOOR BELT MOULDING ASSY LH (See page 76-30)

12. REMOVE REAR DOOR WINDOW FRAME MOULDING FRONT LH (See page 76-34)

13. REMOVE REAR DOOR WINDOW FRAME MOULDING UPPER LH (See page 76-34)

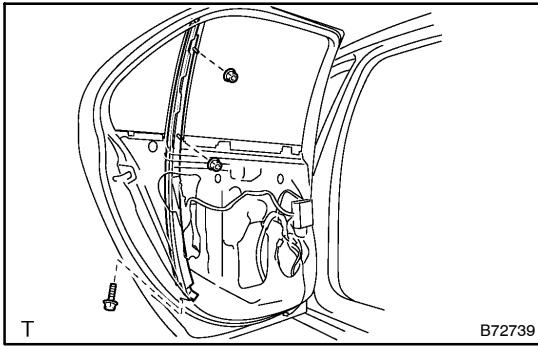

14. REMOVE REAR DOOR WINDOW DIVISION BAR SUB-ASSY LH

- (a) Remove the 2 nuts, bolt and division bar.

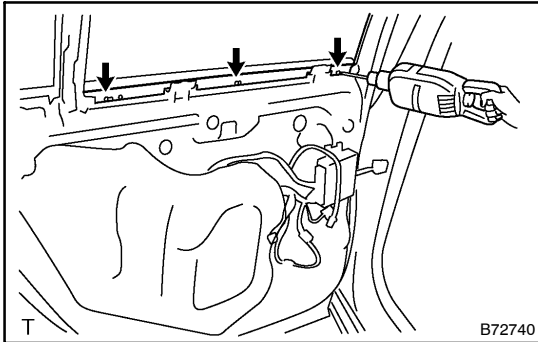

15. REMOVE REAR DOOR GLASS RUN LH

- (a) Using a drill of less than \varnothing 4 mm (0.16 in.), drill out the heads of the 3 rivets and remove the glass run.

NOTICE:

- **Be sure to gently place the drill perpendicular to the rivet to prevent the rivet hole and the drill itself from being damaged.**
 - **Be careful as the cut rivet will become very hot.**
- (b) Even if the flange is taken off, continue drilling and push out the remaining fragments using the drill.
- (c) Using a vacuum cleaner, remove the drilled rivet and dust from the inside of the door.

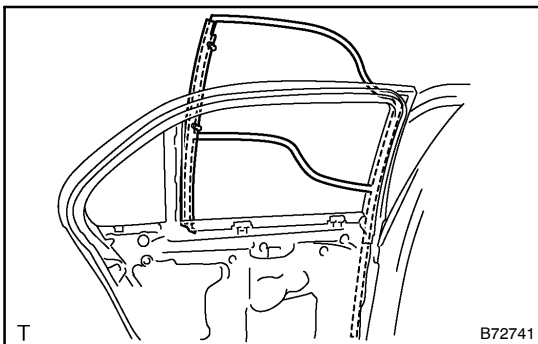

- (d) Remove the glass run as shown in the illustration.

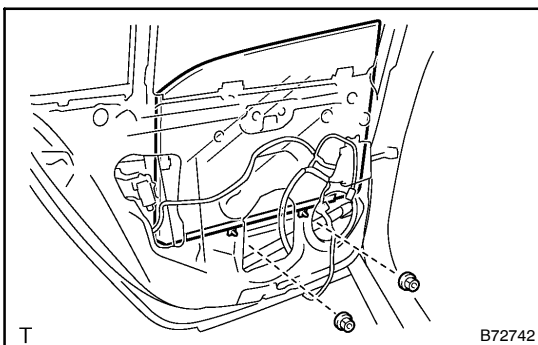

16. REMOVE REAR DOOR GLASS SUB-ASSY LH

HINT:

Insert a shop rag inside the door panel to prevent the glass from being scratched.

- (a) Move the door glass until the bolts appear in the service holes.
- (b) Remove the 2 nuts and door glass.

NOTICE:

Be careful when removing the bolts as the glass may fall and become damaged.

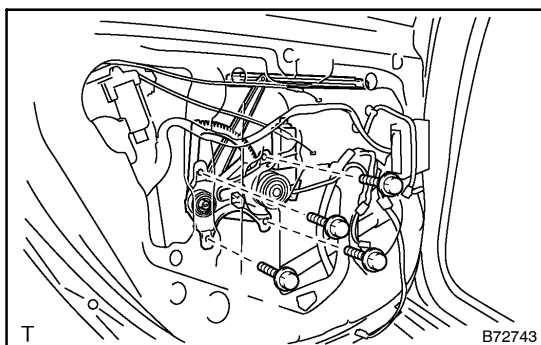

17. REMOVE REAR DOOR WINDOW REGULATOR SUB-ASSY LH

- (a) Disconnect the window regulator connector.
- (b) Remove the 4 bolts and window regulator.

HINT:

Remove the window regulator through the service hole.

NOTICE:

Be careful when removing the bolts as the window regulator may fall and become damaged.

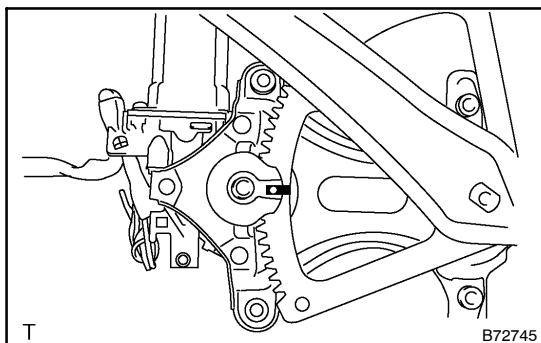

18. REMOVE POWER WINDOW REGULATOR MOTOR ASSY LH REAR

- (a) Place the matchmarks on the window regulator motor bracket and regulator gear.

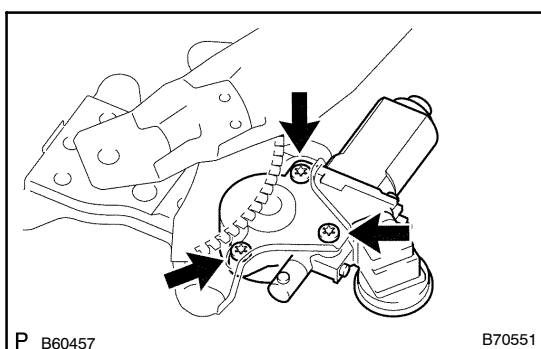

- (b) Using a T25 torx[®] driver, remove the 3 screws and motor.

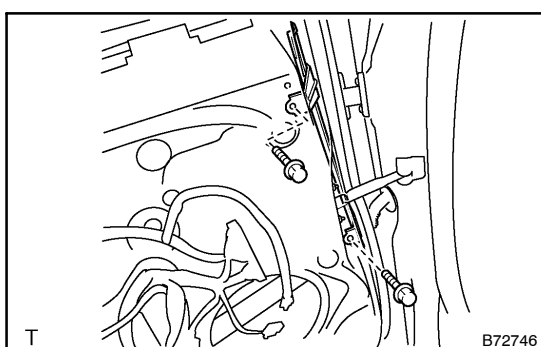

19. REMOVE REAR DOOR WINDOW GUIDE SUB-ASSY FRONT LH

- (a) Remove the 2 bolts and guide.

HINT:

Remove the guide through the service hole.

NOTICE:

Be careful when removing the bolts as the guide may fall and become damaged.

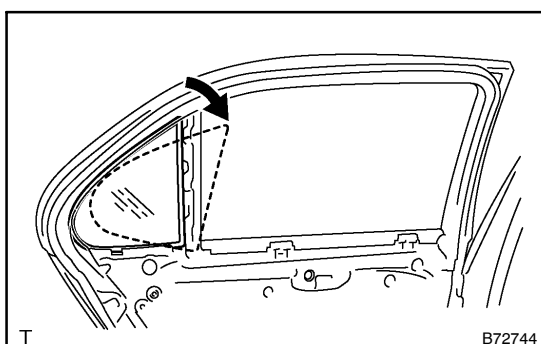

20. REMOVE REAR DOOR QUARTER WINDOW GLASS LH

- (a) Remove the window glass in the direction indicated by the arrow mark in the illustration.

NOTICE:

Be careful not to damage the glass.

- (b) Remove the quarter window glass weatherstrip.

**21. REMOVE REAR DOOR LOCK ASSY LH**

- (a) Disconnect the door lock connector.
- (b) w/o Door closer:
Using a T30 torx[®] wrench, remove the 3 screws and door lock.
- (c) w/ Door closer:
Using a T30 torx[®] wrench, remove the 4 screws and door lock.

HINT:

Remove the door lock through the service hole.

NOTICE:

Be careful when removing the bolts as the door lock may fall and become damaged.

HINT:

Remove the door lock through the service hole.

- (d) Remove the door remote control cable and door inside locking cable.

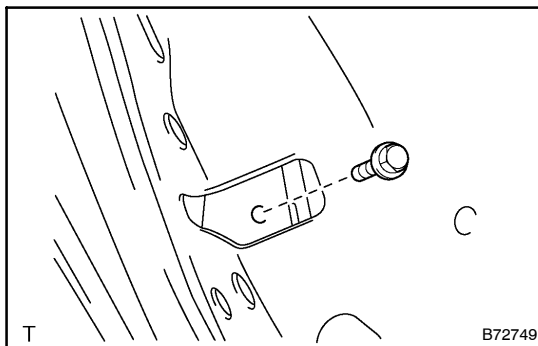
**22. REMOVE DOOR OUTSIDE HANDLE COVER ASSY**

- (a) Remove the bolt and cover.

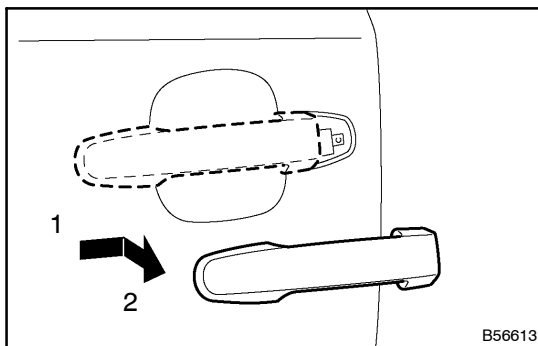
**23. REMOVE REAR DOOR OUTSIDE HANDLE ASSY LH**

- (a) w/ Smart key system:
Disconnect the connector.
- (b) Remove the handle by sliding and pulling it in the direction indicated by the arrow mark in the illustration.
- (c) Remove the outside handle pad front and rear.

NOTICE:

If the release plate is not pulled and held when removing the handle, the release plate will interfere with the handle and become damaged.

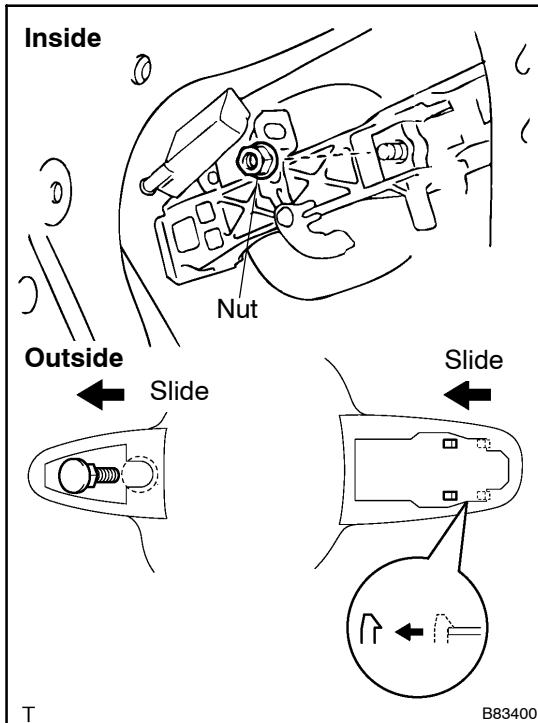

24. REMOVE REAR DOOR OUTSIDE HANDLE FRAME SUB-ASSY LH

- (a) Remove the nut.
- (b) Slide the outside handle frame to remove it.

HINT:

Remove the outside handle frame through the service hole.

- (c) Remove the lock open rod from the outside handle frame.

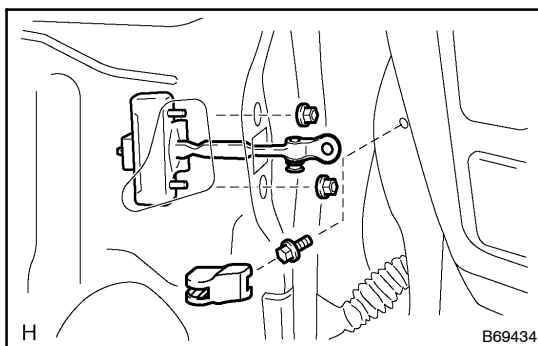

25. REMOVE REAR DOOR CHECK ASSY LH

- (a) Remove the cover.
- (b) Remove the bolt, 2 nuts and door check.

HINT:

Remove the door check through the service hole.

NOTICE:

Be careful when removing the bolts as the door check may fall and become damaged.

26. REMOVE REAR DOOR WEATHERSTRIP LH

- (a) Using a clip remover, disengage the clips and remove the weatherstrip.

HINT:

If clips are damaged during removal, replace them.

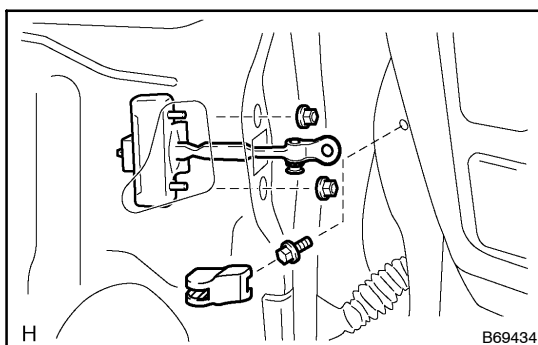

27. INSTALL REAR DOOR CHECK ASSY LH

- (a) Apply MP grease to the sliding areas of the door check.
- (b) Install the door check to the door panel with the 2 nuts.

Torque: 8.0 N·m (82 kgf·cm, 71 in·lbf)

- (c) Apply adhesive to the threads of the bolt.

Adhesive:

Part No. 08833-00070, THREE BOND 1324 or equivalent

- (d) Install the door check to the body panel with the bolt.

Torque: 27 N·m (275 kgf·cm, 20 ft·lbf)

- (e) Install the cover.

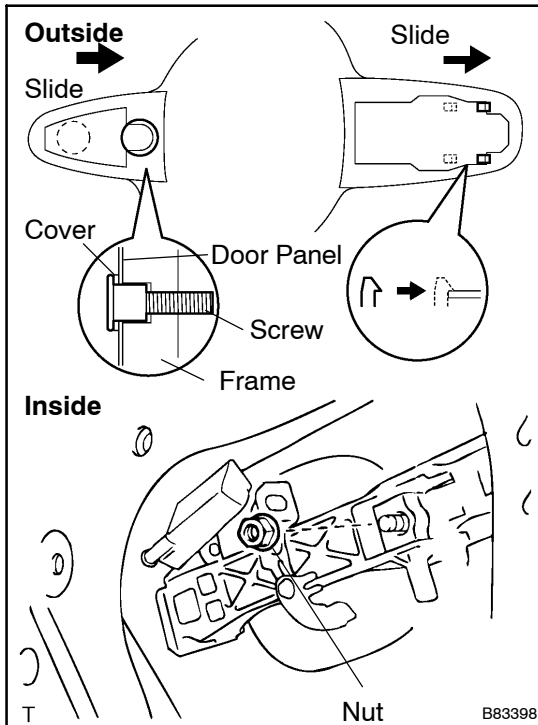

28. INSTALL REAR DOOR OUTSIDE HANDLE FRAME SUB-ASSY LH

- Apply MP grease to the sliding areas of the frame.
- Install the frame with the nut.

Torque: 5.5 N·m (56 kgf·cm, 49 in·lbf)

NOTICE:

A cover should be inserted between the nut and the door panel.

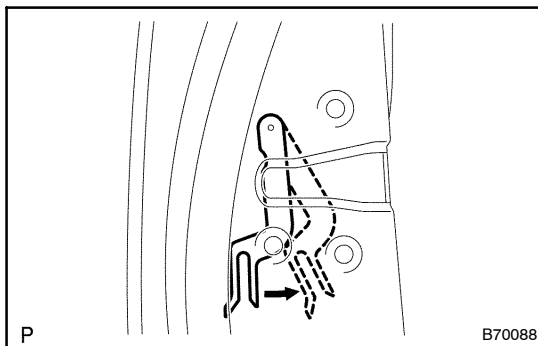

29. INSTALL REAR DOOR OUTSIDE HANDLE ASSY LH

- Install the outside handle pad front and rear.
- Pull and hold the release plate of the frame as shown in the illustration.

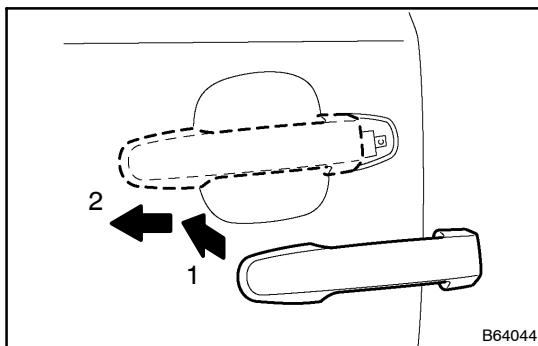

- Install the handle by pushing it in the direction indicated by the arrow marks in the illustration.

NOTICE:

If the release plate is not pulled and held when installing the handle, the release plate will interfere with the handle and become damaged.

- w/ Smart key system:
Connect the connector.

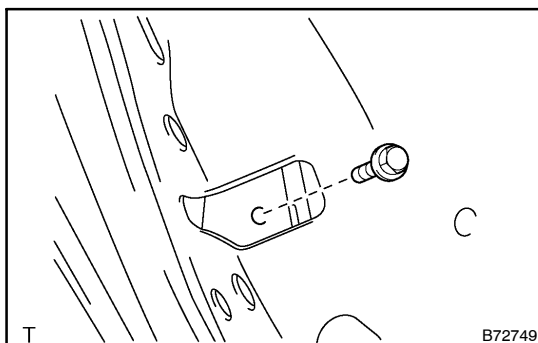

30. INSTALL REAR DOOR INSIDE HANDLE COVER

- Install the cover with the bolt.

Torque: 5.5 N·m (56 kgf·cm, 49 in·lbf)

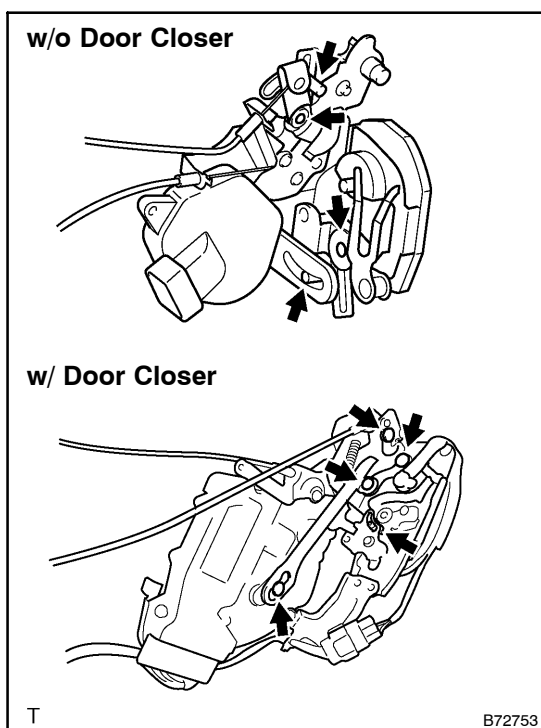

31. INSTALL REAR DOOR LOCK ASSY LH

- (a) Apply MP grease to the sliding and rotating areas of the door lock.

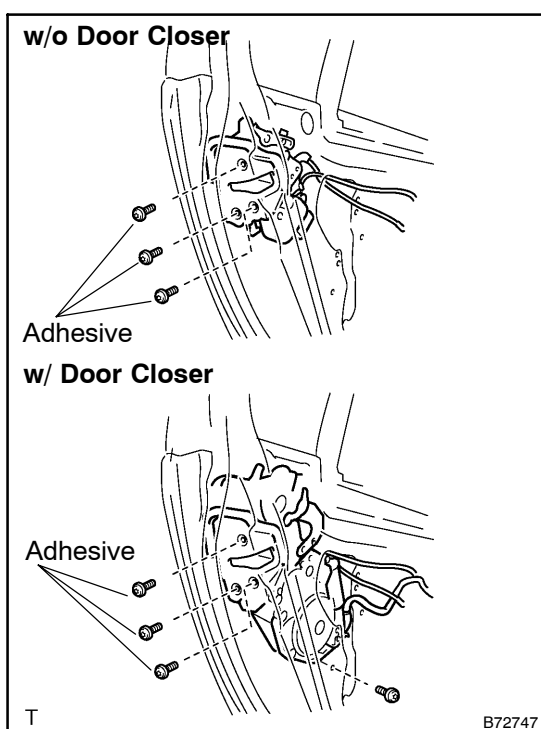

- (b) Apply adhesive to the threads of the 3 screws.

Adhesive:

Part No. 08833-00070, THREE BOND 1324 or equivalent

- (c) w/o Door closer:
Using a T30 torx[®] wrench, install the door lock with the 3 screws.
Torque: 5.5 N·m (56 kgf·cm, 44 in·lbf)
- (d) w/ Door closer:
Using a T30 torx[®] wrench, install the door lock with the 4 screws.
Torque: 5.5 N·m (56 kgf·cm, 44 in·lbf)
- (e) Connect the door lock connector.

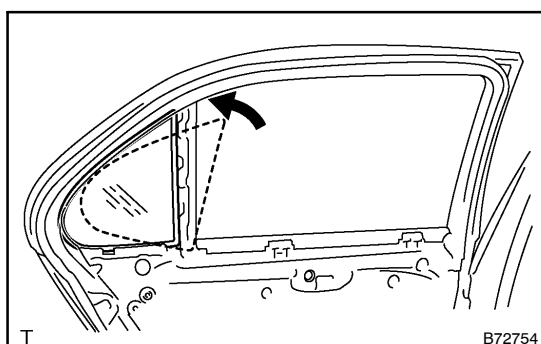

32. INSTALL REAR DOOR QUARTER WINDOW GLASS LH

- (a) Install the quarter window weatherstrip on the glass.

NOTICE:

Be careful not to damage the glass.

- (b) Install the quarter window glass in the direction indicated by the arrow mark in the illustration.

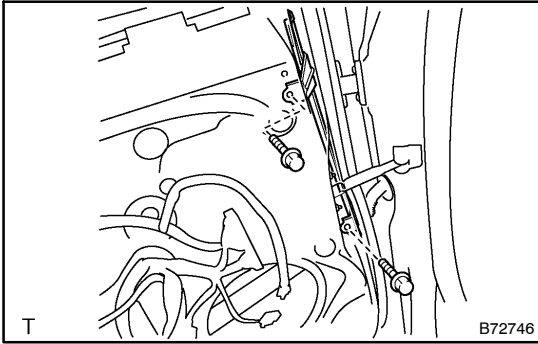

33. INSTALL REAR DOOR WINDOW GUIDE SUB-ASSY FRONT LH

- (a) Instal the guide with the 2 bolts.
Torque: 8.0 N·m (82 kgf·cm, 71 in·lbf)

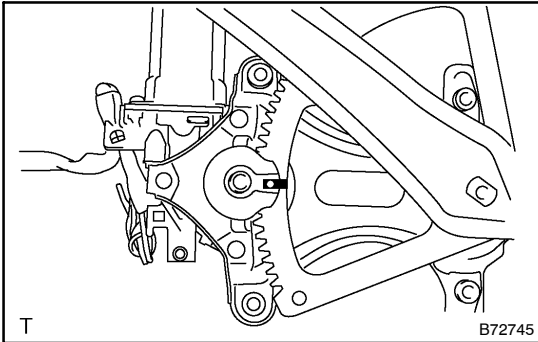

34. INSTALL POWER WINDOW REGULATOR MOTOR ASSY LH REAR

- (a) Align the matchmarks. Keep them aligned until the window glass installation is complete.

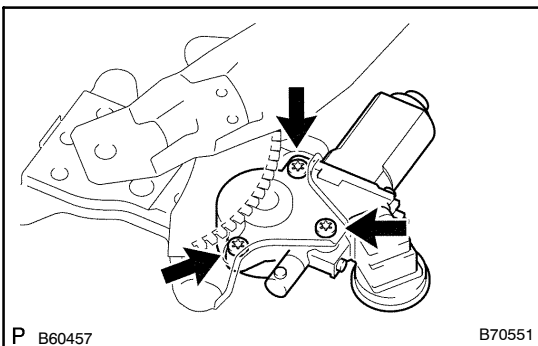

- (b) Using a T25 torx[®] driver, install the motor with the 3 screws.

Torque: 5.5 N·m (56 kgf·cm, 49 in·lbf)

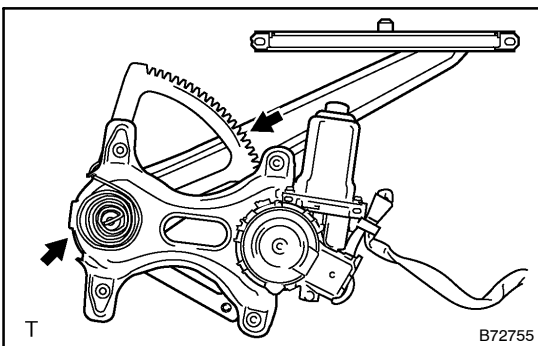

35. INSTALL REAR DOOR WINDOW REGULATOR SUB-ASSY LH

- (a) Apply MP grease to the sliding and rotating areas of the window regulator.

NOTICE:

Do not apply grease to the spring of the window regulator.

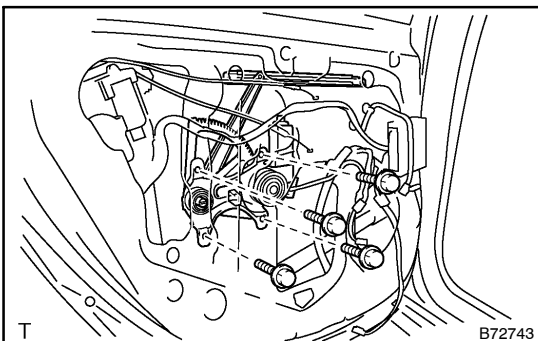

- (b) Install the window regulator with the 4 bolts.

Torque: 8.0 N·m (82 kgf·cm, 71 in·lbf)

- (c) Connect the window regulator connector.

NOTICE:

Be careful not to drop the window regulator as it may become damaged.

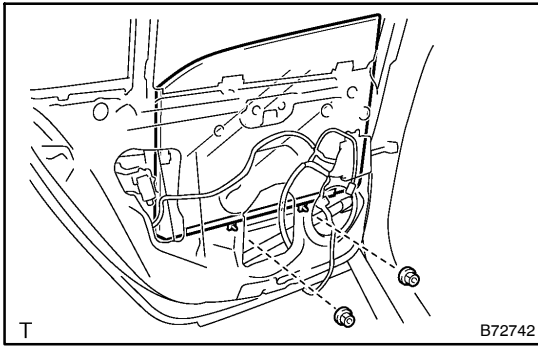

36. INSTALL REAR DOOR GLASS SUB-ASSY LH

- (a) Install the glass with the 2 nuts.
Torque: 5.5 N·m (56 kgf·cm, 49 in·lbf)

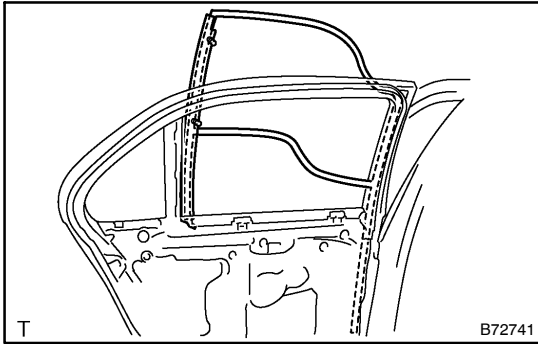

37. INSTALL REAR DOOR GLASS RUN LH

- (a) Install the glass run as shown in the illustration.

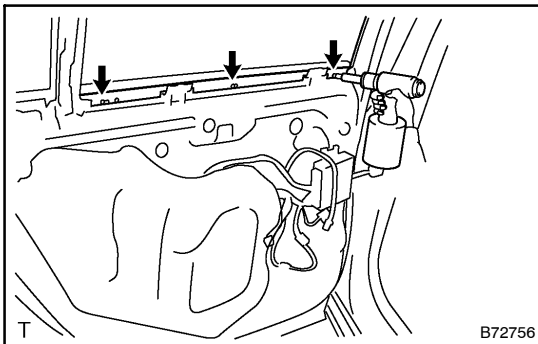

- (b) Using a hand riveter or an air riveter, install the glass run to the door with the 3 rivets.

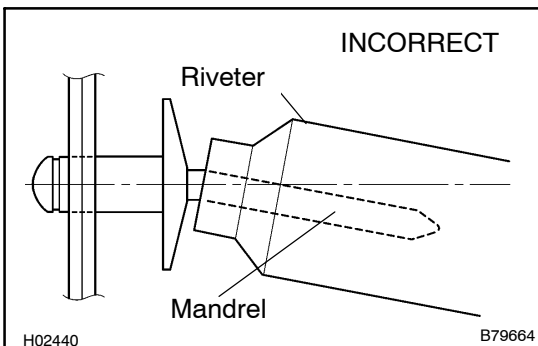

NOTICE:

- Do not prize the riveter. The riveter will be damaged and the mandrel will bend.

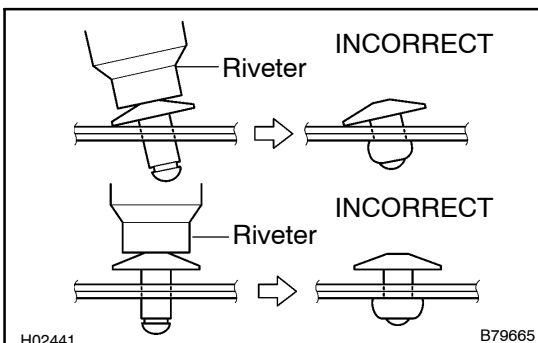

- Do not tilt the riveter when fastening the rivet to the glass run as this will cause the rivet to be loose.
- Do not have any space between the rivet head and the glass run. The rivet head must be completely flat against the glass run.

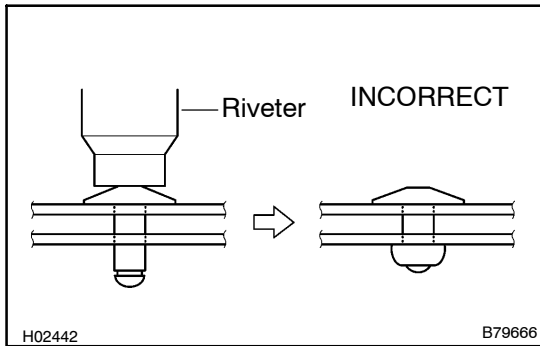

- Do not have any space between the glass runs. Firmly hold together the 2 items while installing the rivet.

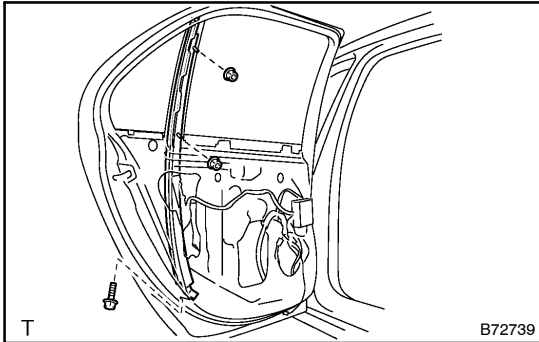

38. INSTALL REAR DOOR WINDOW DIVISION BAR SUB-ASSY LH

- (a) Install the division bar with the 2 nuts and bolt.
Torque: 8.0 N·m (82 kgf·cm, 71 in·lbf)

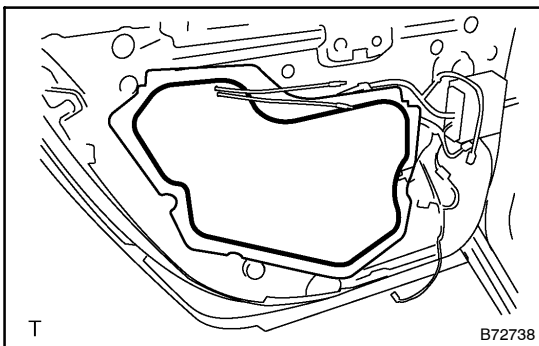

39. INSTALL REAR DOOR SERVICE HOLE COVER LH

- (a) Apply butyl tape to the door as shown in the illustration.
 (b) Install a new service hole cover.

HINT:

- When installing the service hole cover, pull out the links and connectors through the service hole cover.
 - There should be no wrinkles or folds after attaching the service hole cover.
 - After attaching the service hole cover, check the sealing quality.
- (c) Connect the 2 connectors and install the wire.
 (d) Install the door electrical key oscillator with the 2 bolts.

40. INITIALIZE POWER WINDOW SYSTEM (See page [05-2083](#))