

**Part Number: 86100-0W090**

Section I - Installation Preparation

**Kit Contents**

Item #	Quantity Req'd.	Description
1	1	Satellite Tuner
2	1	Tuner Cable
3	1	Tuner Bracket
4	1	Antenna
5	1	Spacer
6	3	Hardware Bags
7	1	xM™ Satellite Radio Brochure

**Hardware Bag Contents 1**

Item #	Quantity Req'd.	Description
1	1	Cushion Tape (50 x 100 mm)
2	2	Wire Tie (AVC-LAN)

**Hardware Bag Contents 2**

Item #	Quantity Req'd.	Description
1	1	Nut (M16)
2	4	Screw (M5 x L6)
3	1	Retainer
4	1	Retainer Screw (M4 x L12)

**Hardware Bag Contents 3**

Item #	Quantity Req'd.	Description
1	1	Template
2	1	Nylon Tape (30 x 30 mm)
3	8	Urethane Tape (30 x 30 mm)

**Additional Items Required For Installation**

Item #	Quantity Req'd.	Description
1A	1	Cover, Compartment Trim (P/N 64712-50010-CD (WITHOUT rear air conditioner.))
1B	1	Cover, Compartment Trim (P/N 64712-50020-CD (WITH rear air conditioner.))
2	1	Clip
3A	7	Rivet (WITHOUT rear air conditioner)
3B	8	Rivet (WITH rear air conditioner)

**Conflicts**

Note:

**Recommended Tools**

<b>Safety Tools</b>	
Safety Goggles	
Vehicle Protection	Fender Cover (Blanket)
<b>Special Tools</b>	
Non-intrusive IR	
Temp Probe/Gun	
<b>Installation Tools</b>	
Ratchet	
Extension	
Socket	10 mm
Screwdrivers	Phillips, and Flat Blade
Masking Tape	50 mm wide
Nylon Panel Removal Tool	e.g. Panel Pry Tool #1 Toyota SST # 00002-06001-01
Rivet Gun	Hand or Air
Utility Knife	or Scissors
Marker Pen	
Torque Wrench	
Drill Motor	
Drill Bits	5 mm, & 8 mm
Tape Measure	
<b>Special Chemicals</b>	
Cleaner	3M™ Prep-Solvent-70

**General Applicability**





Note:

**Recommended Sequence of Application**

Item #	Accessory
1	
2	
3	

\*Mandatory

**Legend**

	<b>STOP:</b> Damage to the vehicle may occur. Do not proceed until process has been complied with.
	<b>OPERATOR SAFETY:</b> Use caution to avoid risk of injury.
	<b>CRITICAL PROCESS:</b> Proceed with caution to ensure a quality installation.
	<b>GENERAL PROCESS:</b> This highlights specific processes to ensure a quality installation.
	<b>TOOLS &amp; EQUIPMENT:</b> Calls out the specific tools and equipment recommended for this process.

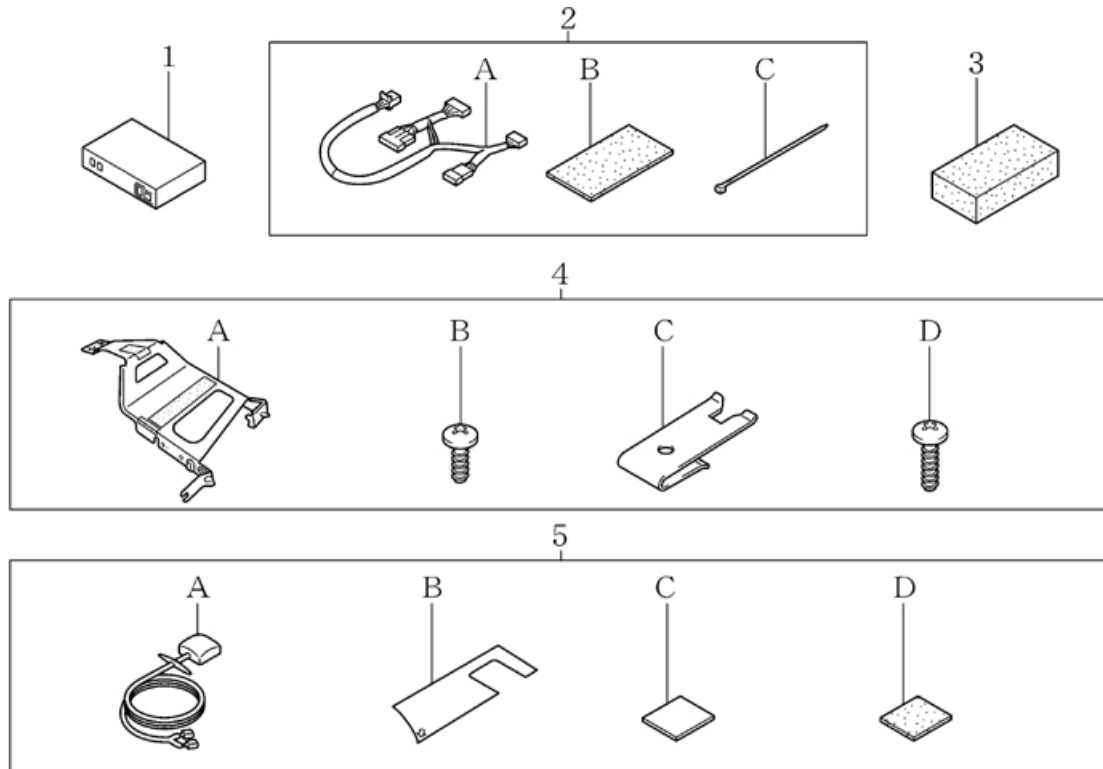

Item #	Parts Name		Qty
1	Satellite Tuner		1
2	A	Tuner Cable	1
	B	Cushion Tape (50 mm x 100 mm)	1
	C	Wire Tie	2
3	Spacer		1
4	A	Tuner Bracket	1
	B	Screw (M5 x L6)	4
	C	Retainer	1
	D	Retainer Screw (M4 x L12)	1
5	A	Antenna	1
	B	Template	1
	C	Nylon Tape (30 mm x 30 mm)	1
	D	Urethane Tape (30 mm x 30 mm)	8

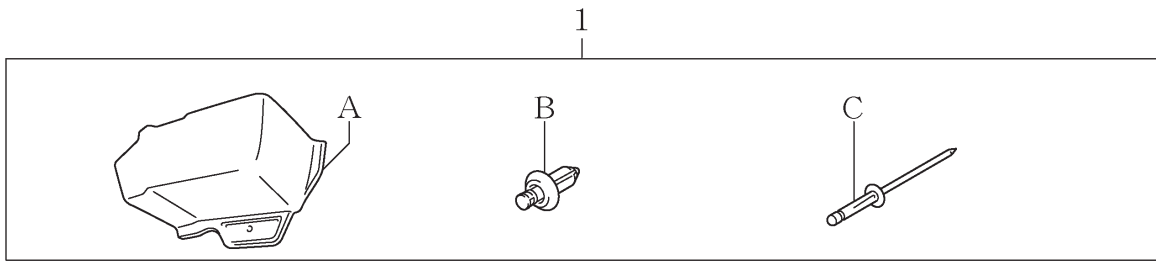

(For vehicles without rear air conditioner)

Item #	Parts Name		Qty
1	A	Cover, luggage compartment trim	1
	B	Clip	1
	C	Rivet	7

(For vehicles with rear air conditioner)

Item #	Parts Name		Qty
1	A	Cover, luggage compartment trim	1
	B	Clip	1
	C	Rivet	8

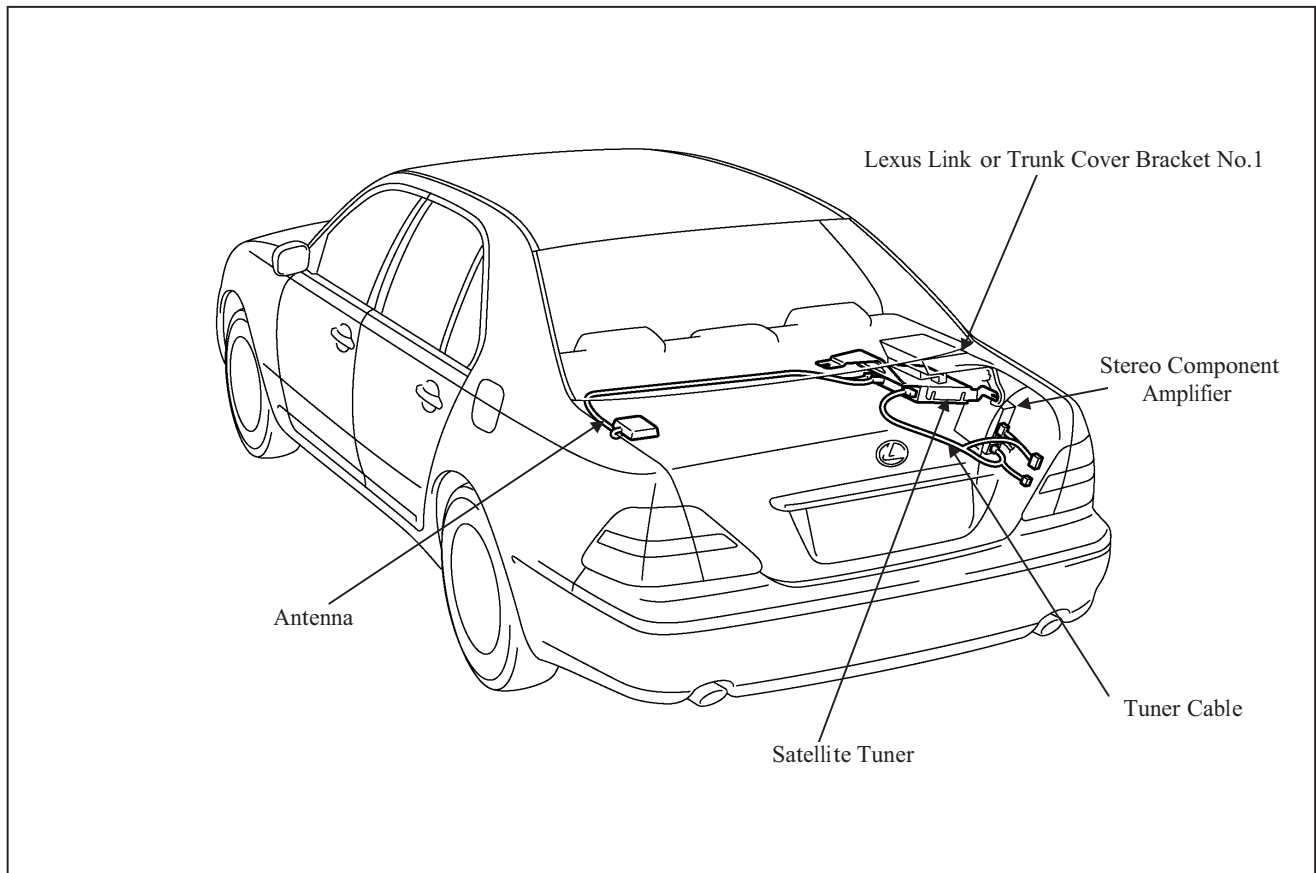

Section II - Installation Procedure

**NOTES:**

Removed Parts:-



Place all removed parts on a protected surface.

Connectors:-



When disconnecting connectors, do not pull on the wires; pull on the connectors.

Wire Ties:-



When using wire ties to secure harness, clip the wire ties after securing them.

**A. Vehicle Disassembly.**

1. Open the trunk first.
2. Remove the negative battery cable. (Fig. A-1)
  - i. Protect the fender before starting.
  - ii. Do not touch the positive terminal with any tool when removing cable.
3. Preinstall luggage compartment trim cover, mark the clip install hole with a marker pen. (Fig. A-2)
4. Remove the floor mat, deck trim side boards on both sides and rear floor finish plate.
  - i. Remove the two (2) clips and deck trim side boards on both sides. (Fig. A-3)
  - ii. Remove the two (2) bolts and two (2) luggage hold belt strikers. (Fig. A-4)
  - iii. Remove the five (5) clips and the rear floor finish plate. (Fig. A-4)

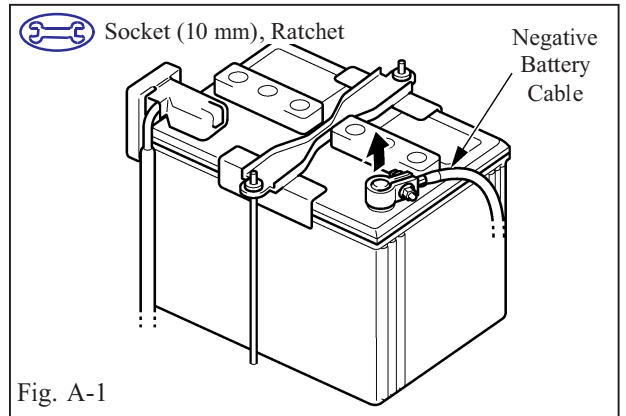

Fig. A-1

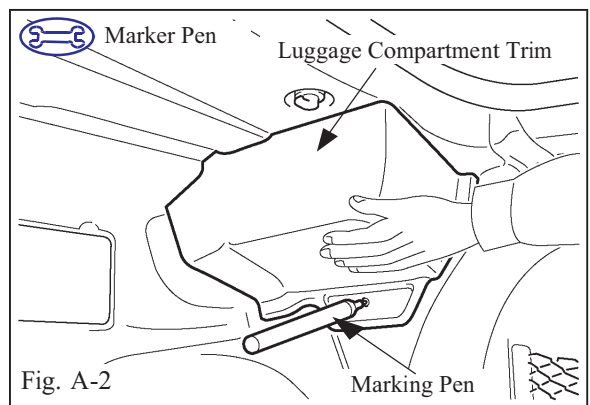

Fig. A-2

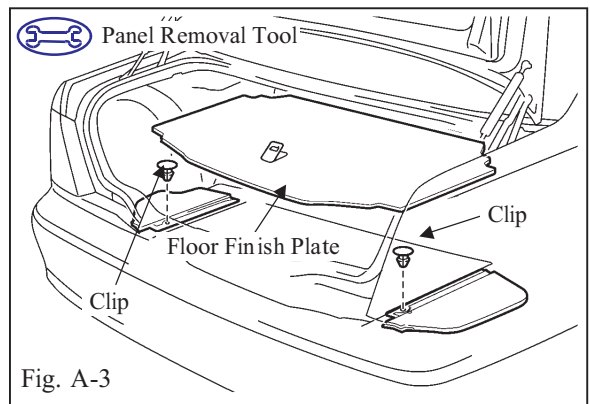

Fig. A-3

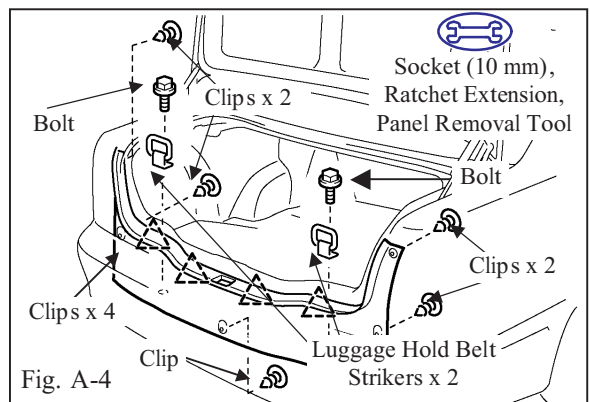

Fig. A-4

5. Remove the luggage compartment light.

- ➔ i. Using a nylon panel removal tool, push the claw on the out side of the luggage compartment light. (Fig. A-5).
- ii. Disconnect the connector and remove the luggage compartment light.

6. Remove the rope hook and wire harness cover. (Fig. A-6)

- ➔ i. Using the nylon panel removal tool, remove the wire harness cover.
- ii. Remove the two rope hooks by rotating the hook 90 degrees counterclockwise, insert a nylon panel removal tool into a slot, and then push the claw to remove the hook.

FOR VEHICLES WITHOUT REAR AIR CONDITIONER. (Step A. 7.)

7. Remove the front luggage compartment trim as follows:

- i. Remove the front luggage compartment trim cover and RHS luggage compartment trim side cover.
- ii. Remove the three (3) clips. (Fig. A-7)

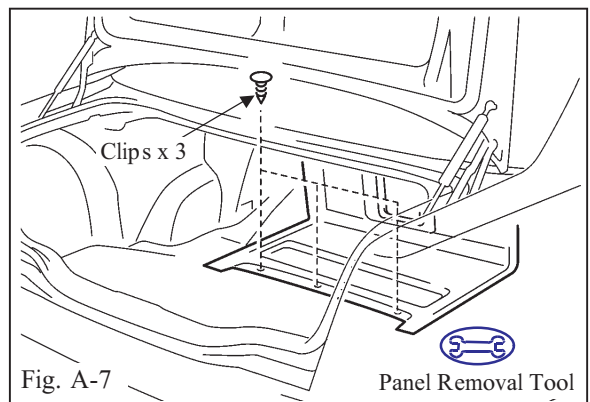
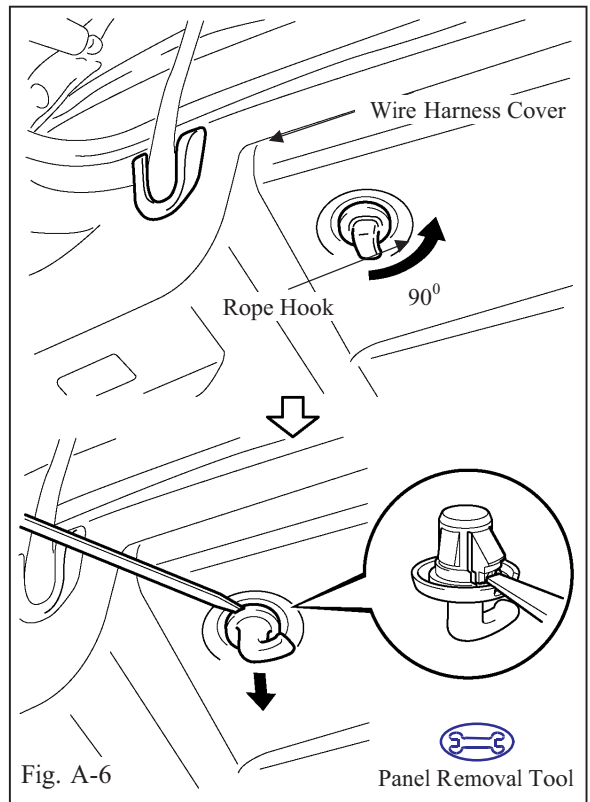
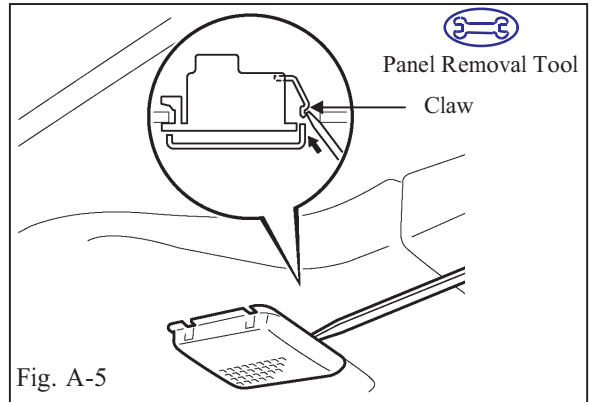

Section II - Installation Procedure

- ➔ iii. Disengage the trim hooks and remove the front luggage compartment trim cover as shown. (Fig. A-8)
- iv. Remove the bolt and luggage hold belt striker. (Fig. A-9)
- v. Remove the three (3) clips and luggage compartment trim side cover. (Fig. A-9)

FOR VEHICLES WITH REAR AIR CONDITIONER. (Step A. 8.)

- 8. Remove the front luggage compartment trim as follows:
  - i. Remove the front luggage compartment trim cover and RHS luggage compartment trim side cover.
  - ➔ ii. Using a nylon panel removal tool, remove the cover. (Fig. A-10)
  - iii. Remove the two (2) bolts and two (2) luggage hold belt strikers. (Fig. A-11)
  - iv. Remove the five clips. (Fig. A-11)

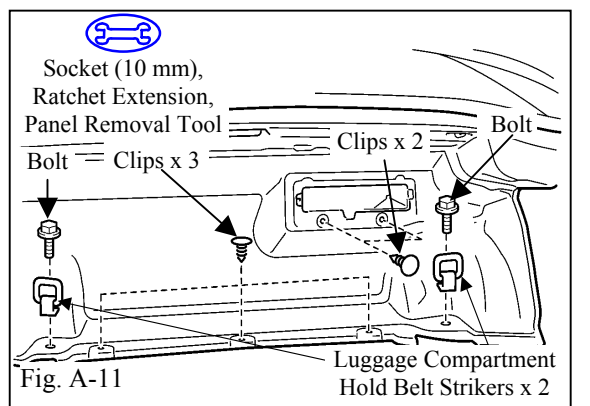
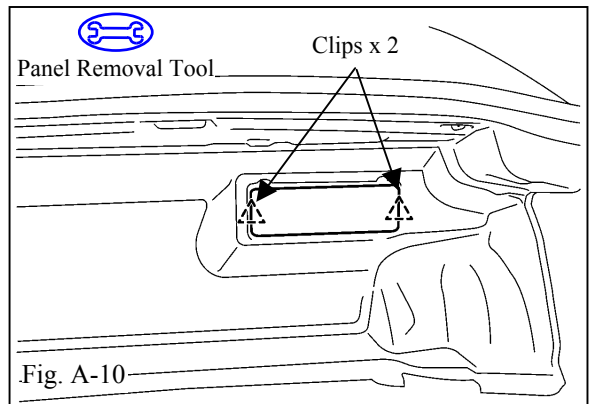
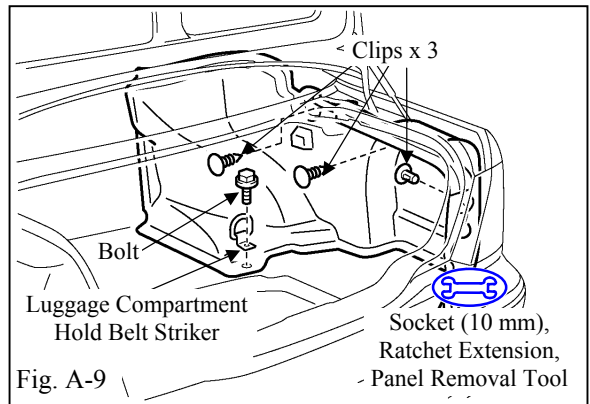
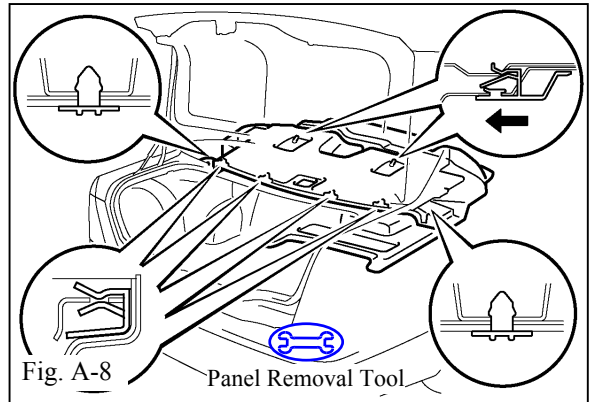



- v. Disengage the trim hooks and remove the front luggage compartment trim cover as shown in the illustration. (Fig. A-12)
- vi. Remove the three (3) clips and luggage compartment trim side cover. (Fig. A-13)

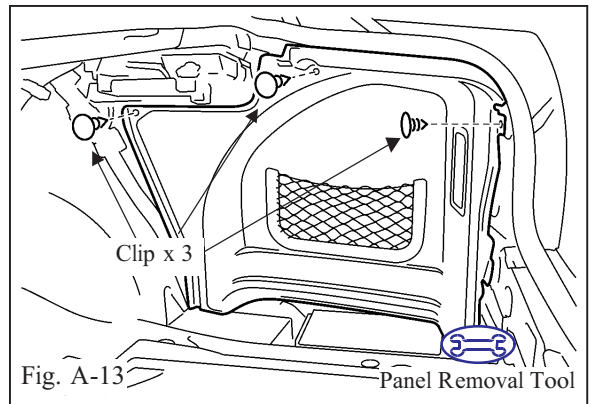
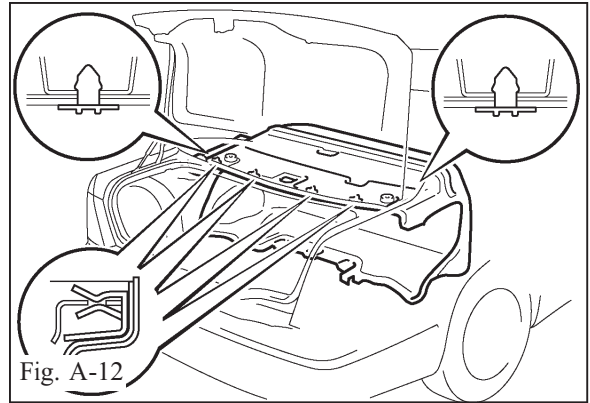

- 9. Lower the trunk lid trim as follows:
  - i. Using a nylon panel removal tool, remove the rear combination light service cover on left side. (Fig. A-14)
  - ii. Remove the five (5) clips. (Fig. A-15)

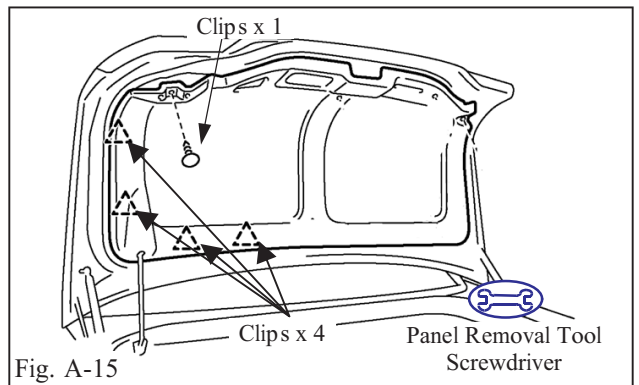
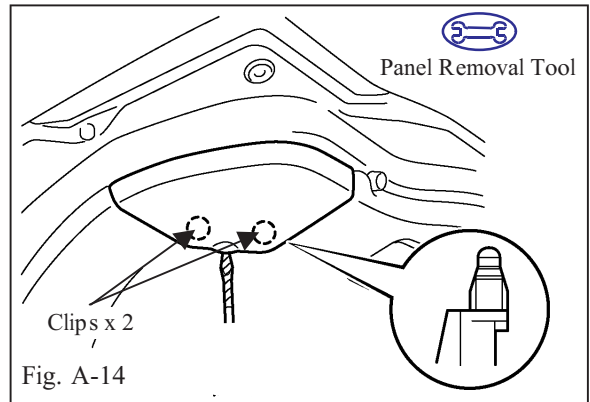

**B. Installing the Satellite Tuner.**

1. Install the four (4) screws and the tuner bracket onto the satellite tuner. (Fig. B-1)  
→ i. Ensure that the orientation of the satellite tuner to the tuner bracket is correct. (Fig. B-1)
2. Remove the nut (Fig. B-2 or Fig. B-3) and retain.
3. Install the satellite tuner under the upper back panel with the nut removed in Step B. 2.
  - i. Install the clip before installing nut.
  - ii. For vehicles **with** Lexus Link see (Fig. B-2)
  - iii. For vehicles **without** Lexus Link see (Fig. B-3)
4. Retainer installation. (Fig. B-4)
  - i. Sandwich the tuner bracket between the retainer.
  - ii. Push the retainer until the claw of the retainer touches the body.
  - iii. Align hole then fasten with retainer screw.

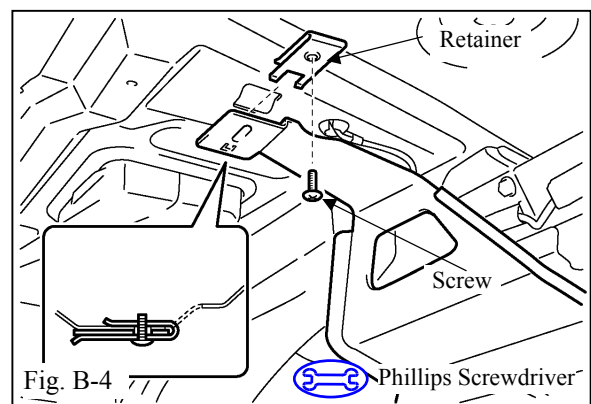
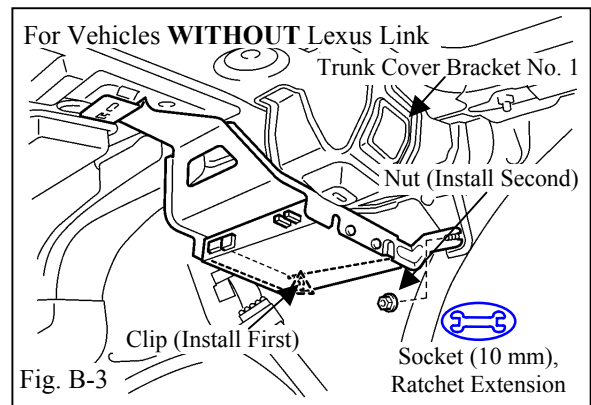
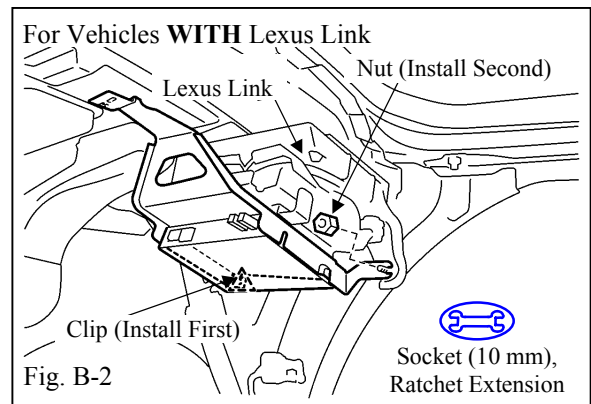
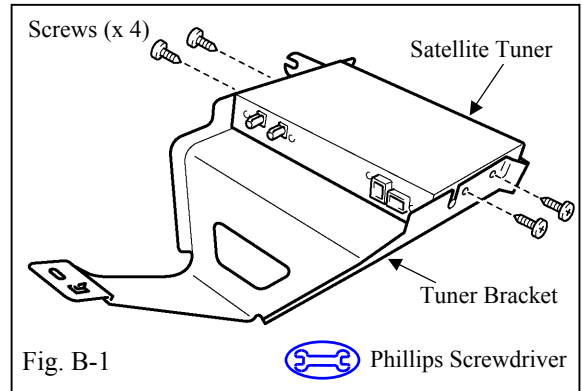



**C. Installing the Tuner Cable.**

**STOP** NOTE: Be careful not to damage the wire harness on the vehicle side.

1. Disconnect the 20 pin and 24 pin stereo component amplifier connectors shown in Fig. C-1.
- ➔ 2. Connect the tuner cable between the stereo component amplifier and the two (2) connectors disconnected at Step C. 1.. (Fig. C-1)
3. Plug the tuner cable into the satellite tuner. (Fig. C-2)
4. Secure the tuner cable with two (2) wire ties as shown. (Fig. C-3)

**D. Installing the Antenna.**

1. Mounting surface must be between 60<sup>0</sup>F and 90<sup>0</sup>F for optimum installation.
- ➔ 2. Clean the antenna mounting area with 3M<sup>TM</sup> Prep Solvent-70. (Fig. D-1)
- ➔ i. When cleaning with 3M<sup>TM</sup> Prep Solvent-70 follow the manufacturer's directions. Do not allow cleaner to air dry.
- ➔ 3. Leave the trunk lid partially open and position and tape the antenna mounting template onto the trunk lid as shown. (Fig. D-1)

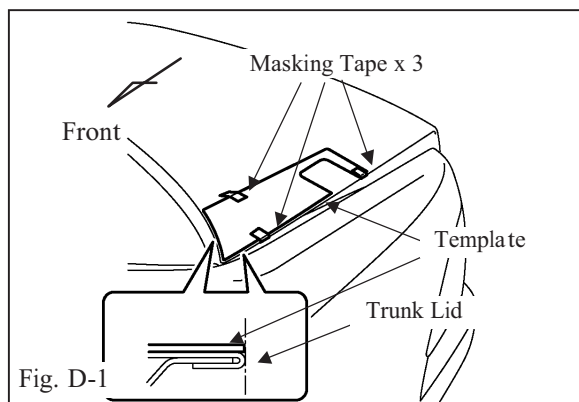
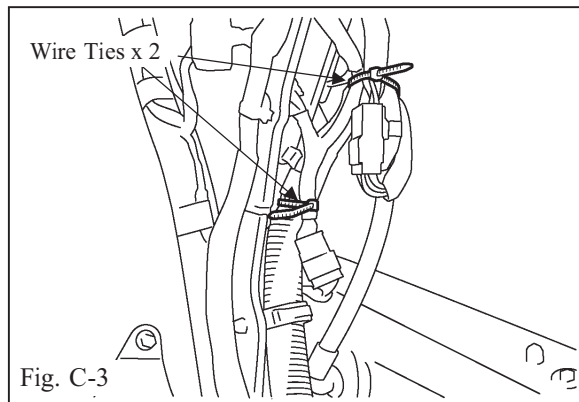
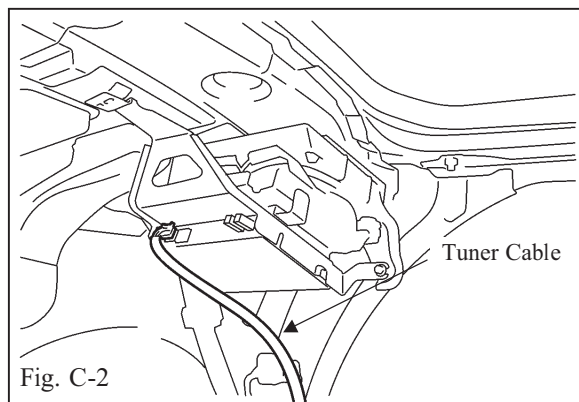
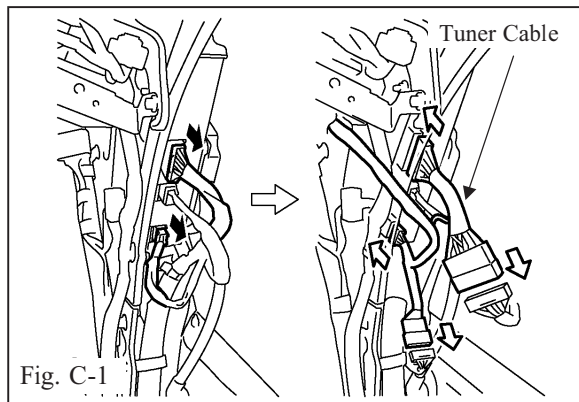

4. Remove the release paper from the back of antenna, and then attach the antenna onto the trunk lid. (Fig. D-2)
5. Align the front edge of the antenna with the template as shown and install it carefully.
  - i. Once attached, the antenna cannot be easily removed.
6. Remove, and then discard the mounting template.



**E. Routing Antenna Cable.**

1. Route the antenna cable beneath the trunk lid. (Fig. E-1)
  - i. Use cable packing, nylon tape and urethane tape to secure the antenna cable so it doesn't rub or pinch when closing the trunk lid.
  - ii. Clean the cable packing and tape mounting areas with 3M™ Prep Solvent-70 using the method defined in Step D. 2. i..
  - iii. Position the end of the cable packing to the round end of the trunk lid where the weather-strip comes in contact with the cable.
2. Reinstall the trunk lid trim.



- i. Verify the antenna cable passes the right side of the vehicle wire harness, then install the trunk lid trim. (Fig. E-2)
- ii. Winding gently, wrap the antenna cable four (4) turns around the existing wire harness. (Fig. E-2)

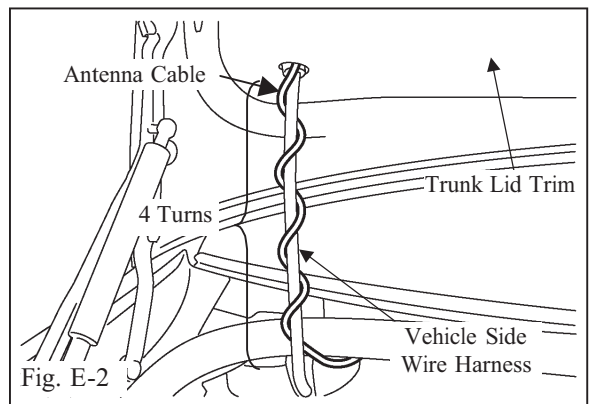
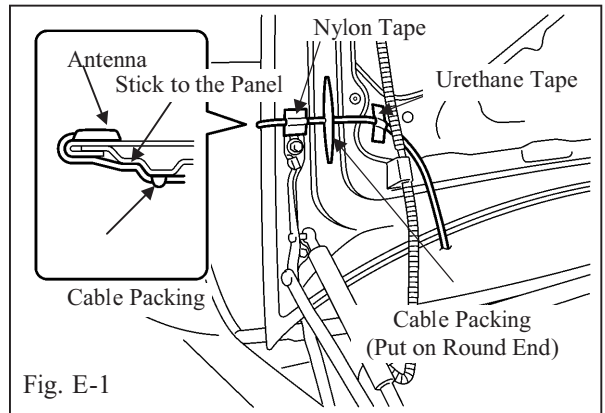
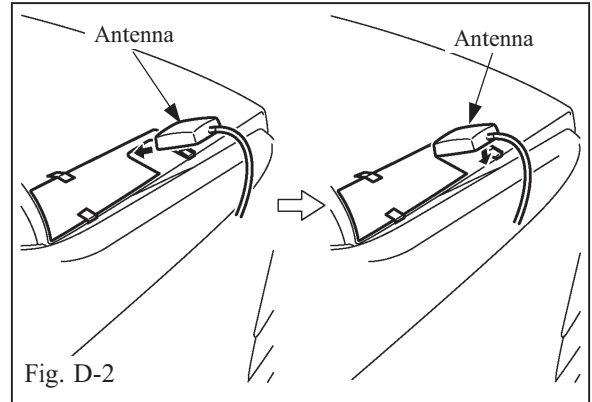



Section II - Installation Procedure

3. Route the antenna cable under the upper back panel.

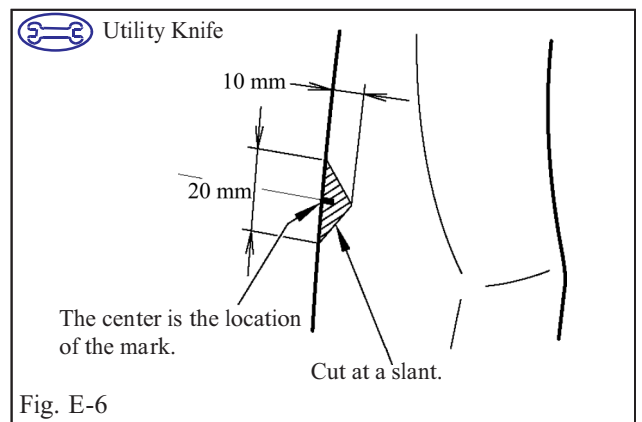
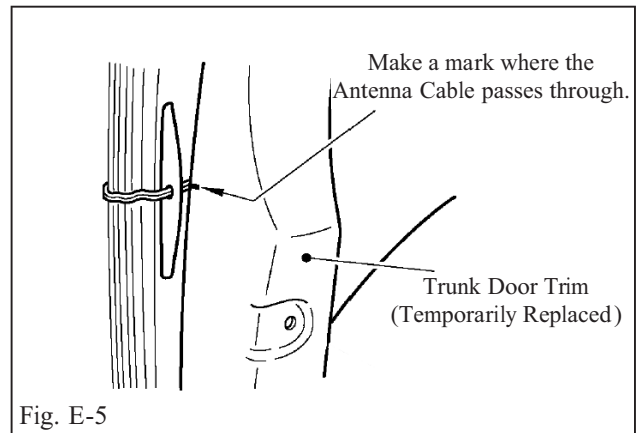
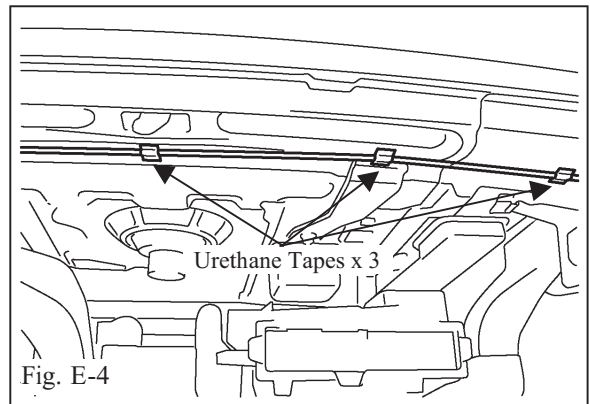
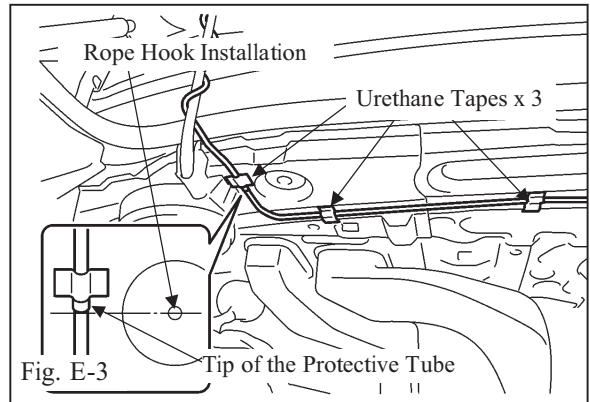

- i. Adjust the antenna cable so the tip of the protective tube of the antenna cable is aligned with the installation hole for the rope hook.
- ii. Apply three (3) urethane tapes at the locations shown. (Fig. E-3)
- iii. Apply three (3) urethane tapes at the locations shown. (Fig. E-4)
- iv. Temporarily replace the trunk lid trim, and make a mark on it where the antenna cable passes through. (Fig. E-5)
- v. Remove the trunk lid trim and make a cut of the size shown in the figure. (Fig. E-6)
- vi. Replace trunk lid trim.



4. Connect the antenna cable to the tuner.
  -  i. Do not allow the antenna cable to come in contact with the edge of the tuner bracket.
5. Apply one (1) urethane tape at the location shown. (Fig. E-7)
6. Bundle and secure extra cable slack to the bottom of the tuner using cushion tape. (Fig. E-7)

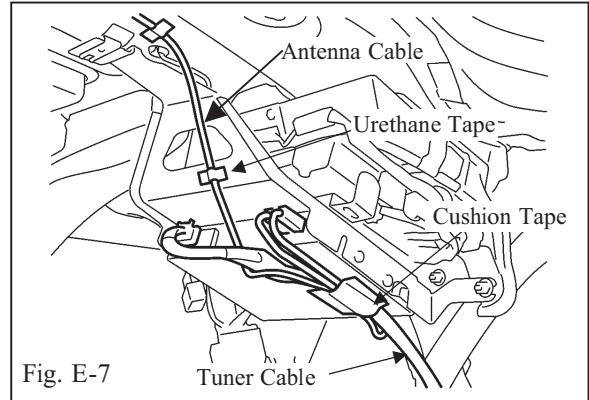

#### F. Installing Luggage Compartment Trim Cover.

FOR VEHICLES WITHOUT REAR AIR CONDITIONER. (Steps F. 1. - F. 3.)

1. Cut the front luggage compartment trim cover and install the luggage compartment trim cover.
  - i. Temporarily install the luggage compartment trim cover onto the front luggage compartment trim cover. (Fig. F-1)
  - ii. Using marker pen make seven (7) reference marks for installing rivets. (Fig. F-1)
  - iii. Remove luggage compartment trim cover.
  - iv. Drill seven (7) 5 mm holes for the rivets. (Fig. F-2)
  -  v. Remove a section of the trim cover with a utility knife or scissors along the pre-marked line as shown. (Fig. F-3)

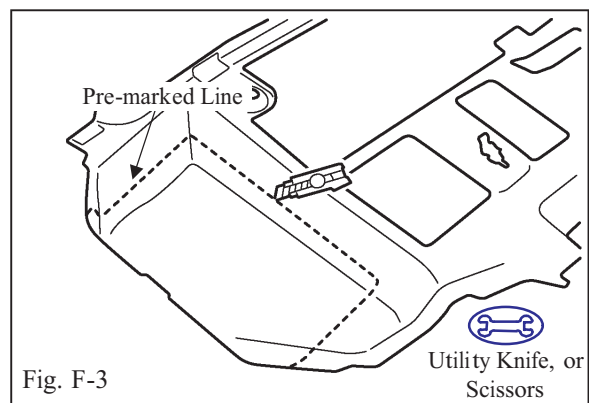
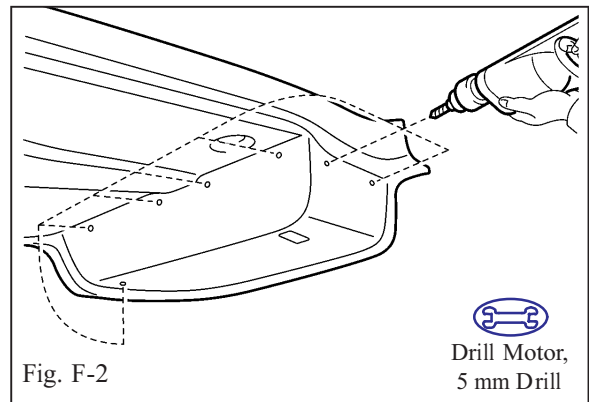
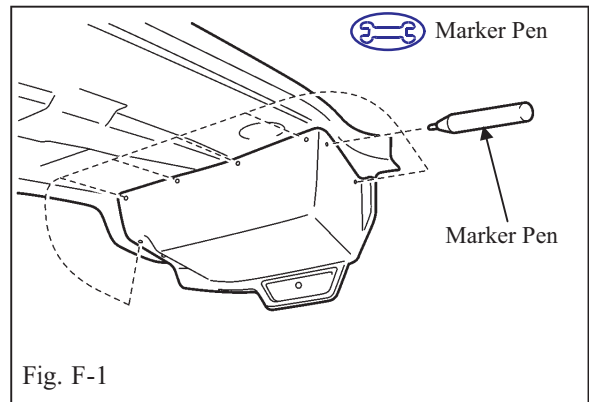

Section II - Installation Procedure

- +** 2. Install the luggage compartment trim cover to the front luggage compartment trim cover with seven (7) rivets. (Fig. F-4)
  - i. Install the rivets in the sequence shown in the illustration.
  - STOP** ii. If the sequence is not followed, the trim will be deformed.
- 3. Cut the luggage compartment trim side cover.
  - i. Using a drill of 8 mm, make a clip hole in the position (marked in Step A. 2.) shown in the (Fig. F-5).
  - +** ii. Remove a section of the trim cover with a utility knife or scissors along the pre-marked line as shown. (Fig. F-6)

FOR VEHICLES WITH REAR AIR CONDITIONER. (Steps F. 4. - F. 6.)

- 4. Cut the front luggage compartment trim cover and install the luggage compartment trim cover.
  - i. Temporarily install the luggage compartment trim cover onto the front luggage compartment trim cover. (Fig. F-7)
  - ii. Using marker pen make eight (8) reference marks for installing rivets. (Fig. F-7)
  - iii. Remove luggage compartment trim cover.

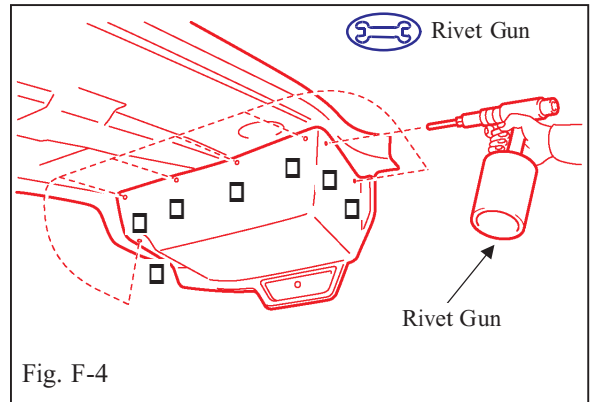

Fig. F-4

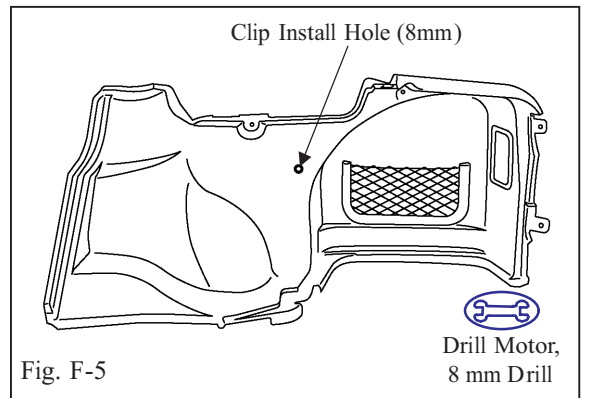

Fig. F-5

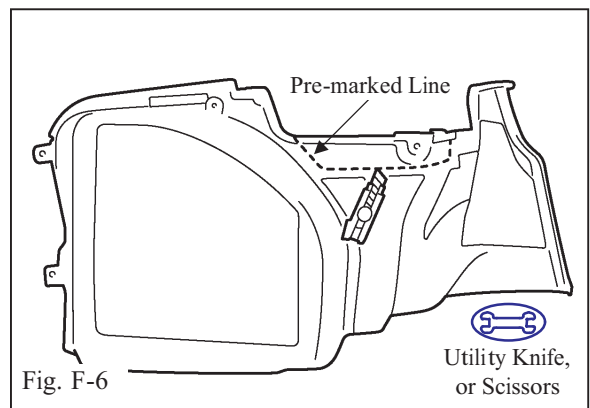

Fig. F-6

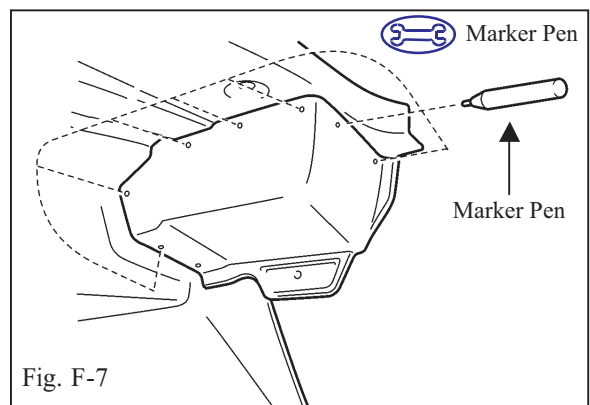



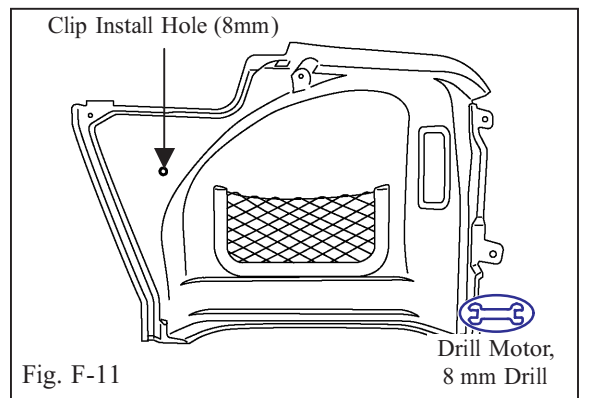
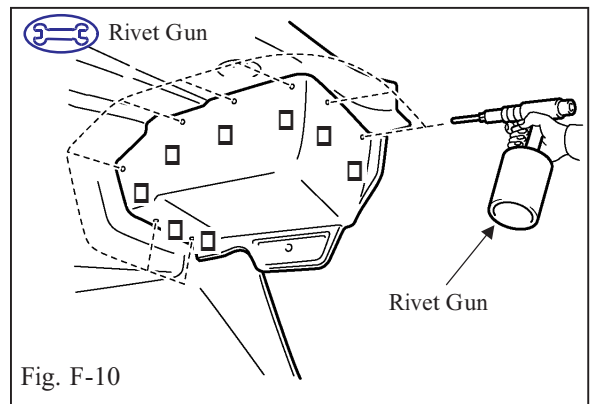
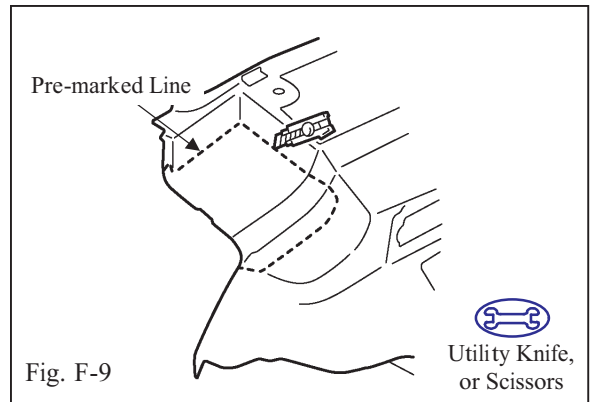
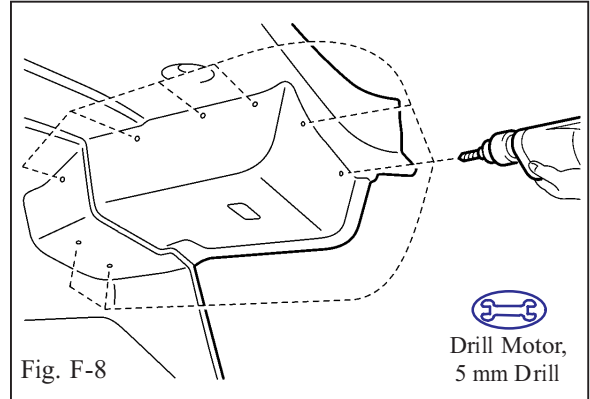

Fig. F-7

Section II - Installation Procedure

-  iv. Drill eight (8) 5 mm holes for the rivets. (Fig. F-8)
-  v. Remove a section of the trim cover with a utility knife or scissors along the pre-marked line as shown. (Fig. F-9)
-  5. Install the luggage compartment trim cover to the front luggage compartment trim cover with eight (8) rivets. (Fig. F-10)
  - i. Install the rivets in the sequence shown in the illustration.
  -  ii. If the sequence is not followed, the trim will be deformed.
- 6. Cut the luggage compartment trim side cover.
  - i. Using a drill of 8 mm, make a clip hole in the position (marked in Step A. 2.) shown in the Fig. F-11.





- ii. Remove a section of the trim cover with a utility knife or scissors along the pre-marked line as shown. (Fig. F-12)

**G. In Process Functional Test.**

1. Temporarily reconnect battery negative cable.
2. Turn ignition key to ACC position.
3. Press the power button on the receiver/player head unit. Verify the backlighting illuminates.
4. Press and release the "SAT" button on the head unit.



- i. Verify that a satellite channel is received, or a "NO SIGNAL" message appears on the display.

**NOTE:** If "ANTENNA" appears (flashing) on the display - then one or both of the antenna cables are disconnected from the satellite tuner.

**NOTE:** If the head unit will not tune or go into satellite mode - then the tuner cable is disconnected from the satellite tuner.



5. Disconnect battery negative cable.

**H. Vehicle Reassembly.**

1. Install spacer on to vehicle side. (Fig. H-1)
  - i. Remove adhesive backing tape from spacer.
2. Reinstall trim pieces in luggage compartment.
  - i. Reinstall the luggage compartment trim side cover, front luggage compartment trim, luggage compartment light, wire harness cover, rear floor finish plate, both deck trim side boards and floor mat.
  - ii. Reinstall the clip into the luggage compartment trim cover. (Fig. H-2).

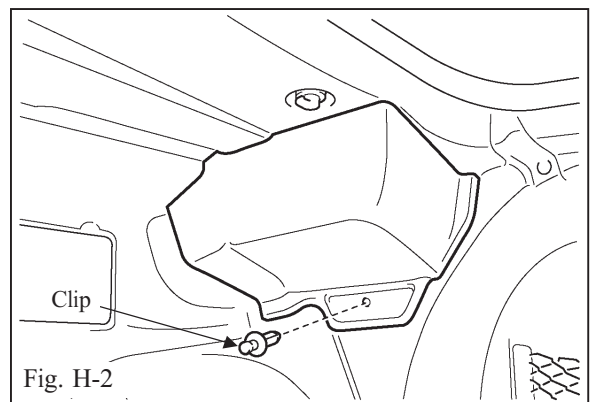
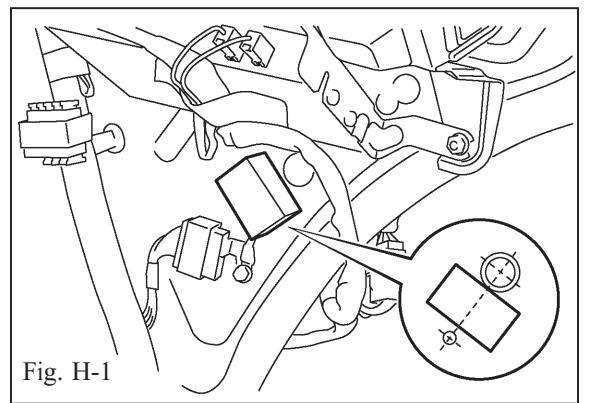
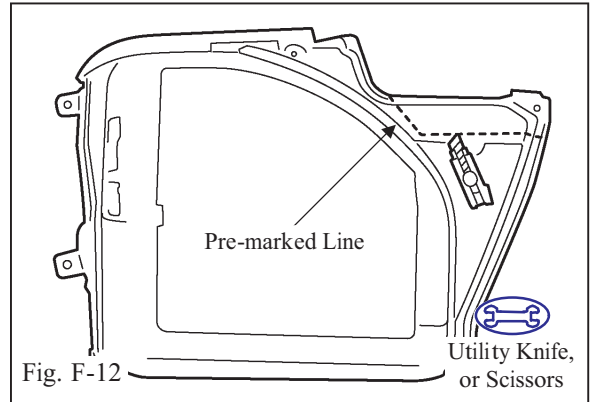

(1) Visually check the position of the hole.  
If the hole is not positioned properly,  
adjust the position of the side trim to  
install the clip.

iii. Reinstall left combination light service  
cover.

3. Replace the floor mat, deck trim side boards  
on both sides and rear floor finish plate.

- i. Replace the five clips and the rear floor  
finish plate. (Fig. H-3)
- ii. Replace two (2) luggage hold belt strikers  
and the two (2) bolts. (Fig. H-3)



(1) Tighten the bolt to 5.0 N-m (44 lbf-in)

iii. Replace the two clips and deck trim side  
boards on both sides. (Fig. H-3)

**I. Complete the Installation.**

1. Reconnect the vehicle's negative battery  
cable. (Fig. I-1)



i. Position the negative terminal to the  
battery (~45 deg.) as shown.



ii. Tighten the nut to 4.1 N-m (36 lbf-in).



iii. Do not touch the positive terminal with  
any tool when replacing the cable.

2. Clean up and remove any trash.



3. Place the owner "xM Satellite Radio"  
brochure and the "Owners Manual" in the  
glove box.

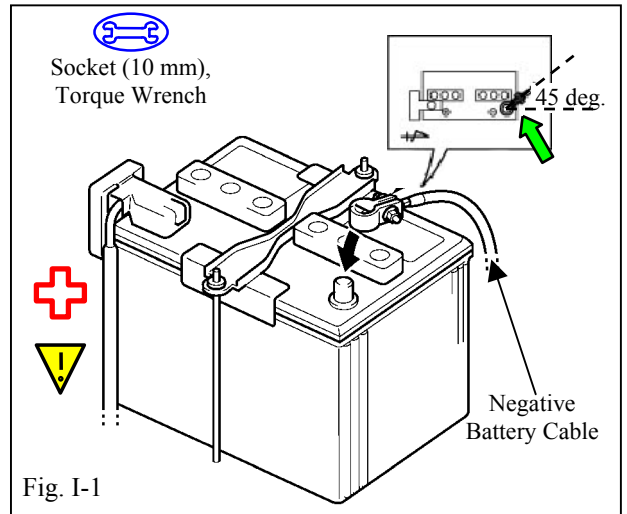
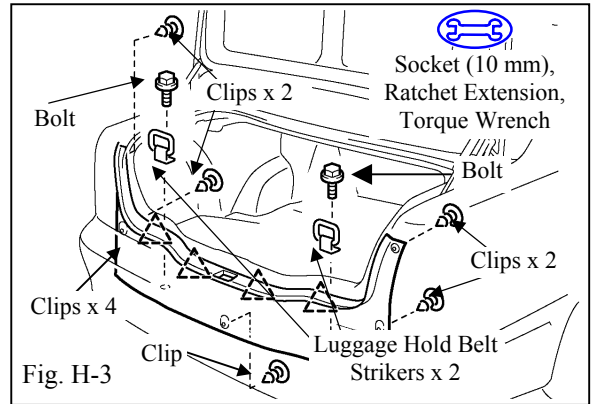





Section III - Functional Verifications

Check: \_\_\_\_\_

Accessory Function Checks

- Satellite Radio Tuner.
- Receiver/player Assembly.

Vehicle Function Checks

- Trunk Lid Light.
- Luggage Compartment Light.

Look For: \_\_\_\_\_

\*Verify the proper operation of the Satellite Radio Tuner.

\*Verify the proper operation of the Receiver/player Assembly

\*(Refer to the receiver assembly and radio owner's manuals.)

Proper operation of trunk lid light.

Proper operation of the luggage compartment light.