

REPLACEMENT

1. REMOVE V-BANK COVER
2. REMOVE AIR CLEANER INLET
3. DRAIN ENGINE COOLANT
 - (a) Remove the 2 radiator caps from the radiator reservoir and radiator.

CAUTION:

To avoid the danger of being burned, do not remove the radiator cap while the engine and radiator are still hot, as fluid and steam can be blown out under pressure.

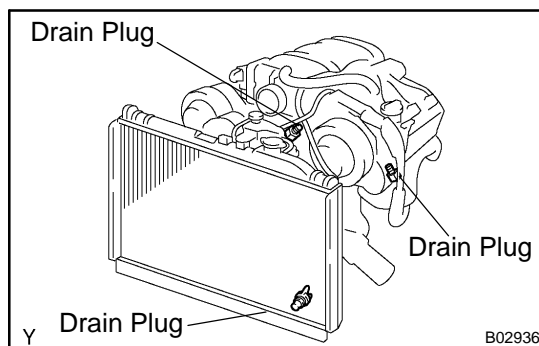

- (b) Remove the 3 drain plugs on the engine and radiator, and drain the coolant.
- (c) Close the 3 drain plugs.

Torque:

12.7 N·m (130 kgf·cm, 9 ft·lbf) for engine drain

4. REFILL WITH ENGINE COOLANT

- (a) Slowly fill coolant to the radiator until it is full.
 - Use of improper coolants may damage engine cooling system.
 - Use "Toyota Long Life Coolant" or equivalent and mix it with plain water according to the manufacturer's directions.
 - Use of the coolant which includes more than 50% (freezing protection down to -35°C (-31°F)) or 60% (freezing protection down to -50°C (-58°F)) of ethylene-glycol is recommended, but not more than 70%.

NOTICE:

- Do not use an alcohol type coolant or plain water alone.
- The coolant should be mixed with plain water (preferably demineralized water or distilled water).
Capacity: 9.8 liters (10.4 US qts, 8.6 Imp. qts)

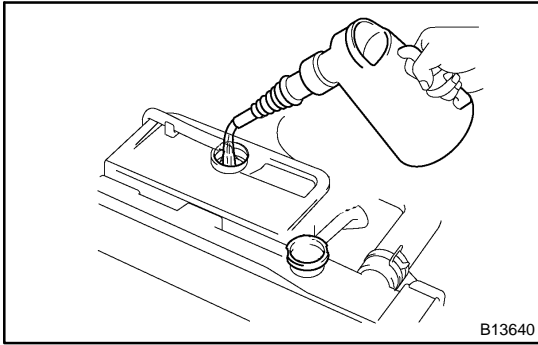

- (b) Slowly pour coolant into the radiator reservoir until it is "FULL".
 - (c) Install the radiator cap to the radiator and radiator reservoir.
 - (d) Bleed the cooling system.
 - Start the engine, and open the heater water valve.
 - Maintain the engine speed at 2,000 – 2,500 rpm, and warm up the engine.
 - (e) Stop the engine, and wait until the engine coolant cools down.
 - (f) Refill coolant to the radiator until it is full and into the reservoir until it is "FULL".
- 5. CHECK ENGINE COOLANT FOR LEAKS**
 - 6. CHECK ENGINE COOLANT SPECIFIC GRAVITY CORRECTLY**
 - 7. INSTALL AIR CLEANER INLET**
 - 8. INSTALL V-BANK COVER**