

## ON-VEHICLE INSPECTION

### 1. ADJUST STANDARD VEHICLE HEIGHT

- (a) Release the parking brake and stabilize the suspensions by pushing up and down on the corners of the vehicle.
- (b) Adjust the shift lever to the N position and settle the tires by shifting the vehicle back and forth by hand.
- (c) Start the engine.
- (d) On the height control switch, first press "HIGH" to raise the vehicle's height, and next press "NORM" to lower it, and then press the switch to change it to the "NORM" position.

#### NOTICE:

**Make sure to release the parking brake and adjust the shift lever to the N position.**

### 2. INSPECT TIRE (SEE PAGE 28-1)

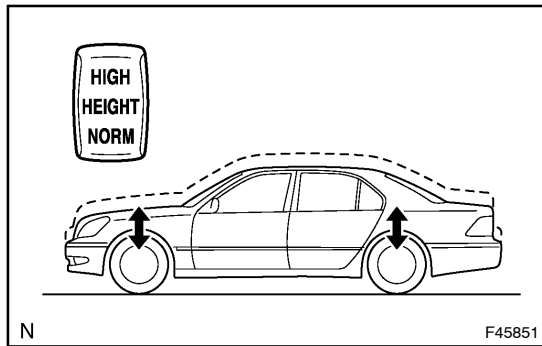

### 3. INSPECT VEHICLE HEIGHT SWITCH FUNCTION

#### NOTICE:

**Perform the procedure with the vehicle vacant and unloaded.**

- (a) Change the height control switch from the "NORM" position to the "HIGH" position and back to the "NORM" position again. Check the time spent and the degree of change in the vehicle's height to reach the target height.
  - "NORM" → "HIGH" position: approx. 20 to 40 seconds**
  - "HIGH" → "NORM" position: approx. 20 to 40 seconds**

**Change in vehicle height: approx. 30 mm (1.18 in.)**

#### NOTICE:

**Turn off the engine to check the vehicle height.**

4 people on the vehicle:

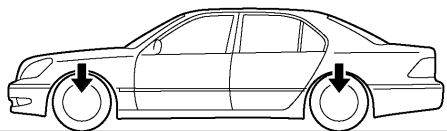

Vehicle height  
control completed:

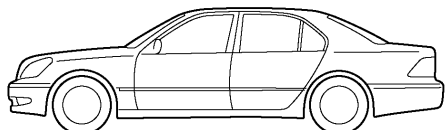

4 people out of the vehicle:

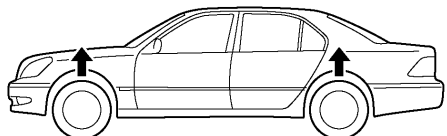

#### 4. INSPECT AUTOMATIC LEVELING FUNCTION

##### NOTICE:

**Make sure the height control switch is in the "NORM" position and the access mode switch is OFF.**

- (a) Turn the ignition switch OFF and have four people (two in the front, two in the rear) ride in the vehicle.

##### HINT:

Each person should weigh approx. 68 kg.

- (b) Start the engine and check the time spent to complete vehicle height control.

**Time to target height: approx. 40 to 60 seconds**

- (c) Turn the ignition switch OFF and then have the four people get out of the vehicle.

- (d) Start the engine and check the time spent to complete vehicle height control.

**Time to target height: approx. 10 to 30 seconds**

**5. CHECK CONNECTIONS OF TUBES FOR AIR LEAKAGE**

- (a) Set the height control switch to the "HIGH" position and raise the vehicle's height.
  - (b) Stop the engine.
  - (c) Apply soapy water to the connections of the tubes and check if there is any air leakage.
- If necessary, replace these parts.

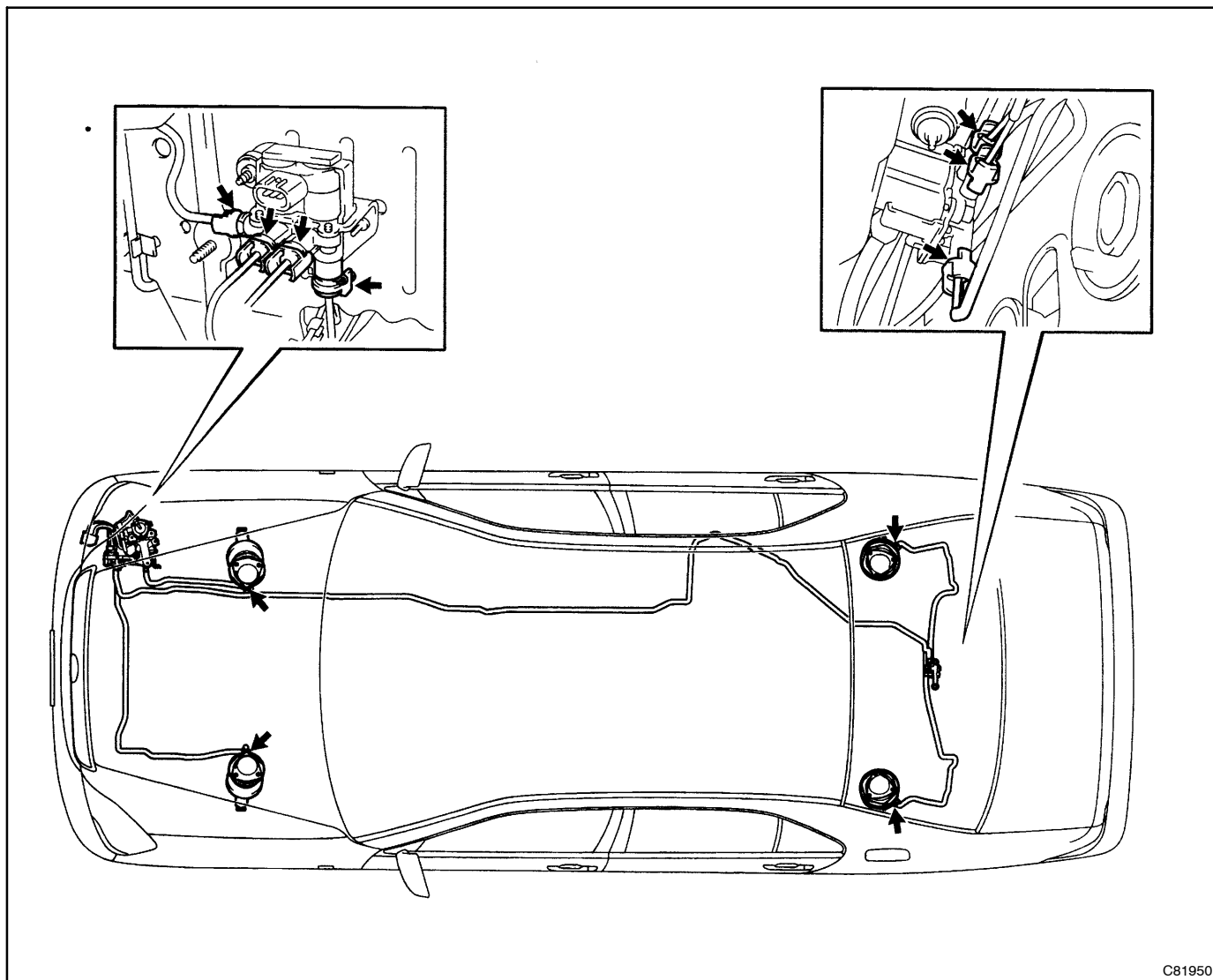

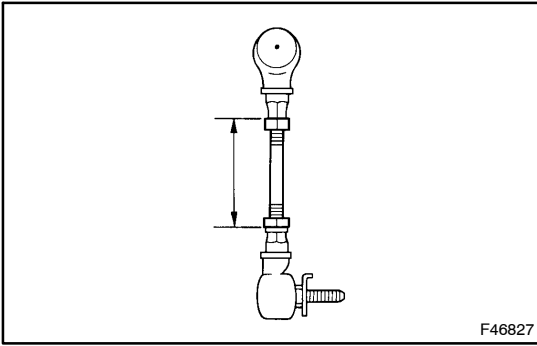

## 6. INSPECT FRONT HEIGHT CONTROL SENSOR LINK LENGTH

- (a) Inspect the link dimension shown in the illustration.  
**Link length (reference): 59.3 mm (2.335 in.)**

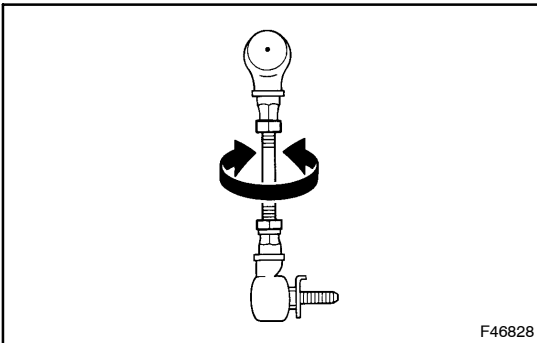

## 7. ADJUST FRONT VEHICLE HEIGHT

- (a) Loosen the 2 lock nuts on the height control sensor link.  
 (b) Turn the bolt of the height control sensor link to adjust the length.

### HINT:

Turning the bolt of the height control sensor link one revolution changes the vehicle height by about 5 mm (0.20 in.).

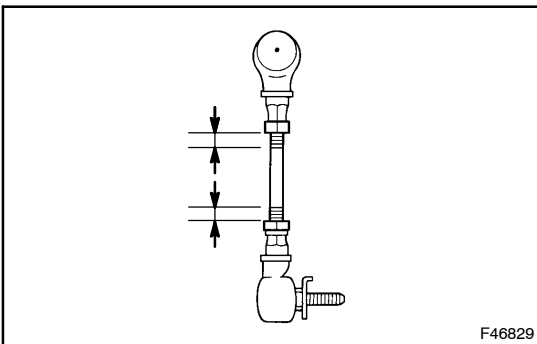

- (c) Check if the height control sensor link dimension shown in the illustration is less than the maximum value.

**Maximum: 19 mm (0.75 in.)**

- (d) Temporarily tighten the 2 lock nuts.

### HINT:

Coat the thread of the bolt with sealer.

### Sealer:

**Part No.08833-00070, THREE BOND 1324 or equivalent**

- (e) Inspect the vehicle height one more time.  
 (f) Tighten the lock nuts.

**Torque: 5.4 N·m (55 kgf·cm, 48 in.-lbf)**

### NOTICE:

**Make sure the ball joint and bracket are parallel when tightening the lock nuts.**

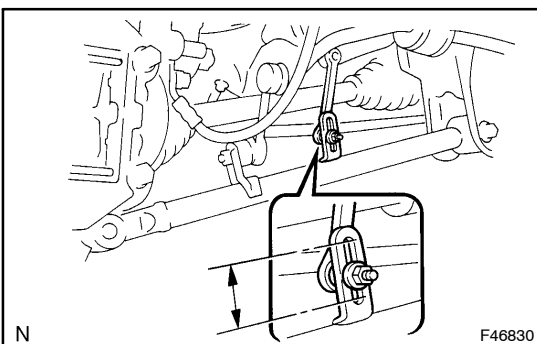

## 8. ADJUST REAR VEHICLE HEIGHT

- (a) The rear vehicle height can be adjusted by moving the installation position of the link on the lower arm.  
 When the link is moved 1 mm (0.04 in.), the vehicle height is adjusted by about 2 mm (0.08 in.).

## 9. INSPECT WHEEL ALIGNMENT (SEE PAGE 26-8)