

6. BASIC INSPECTION

(a) Check the fluid level.

HINT:

- Drive the vehicle so that the engine and transmission are at normal operating temperature.

Fluid temp.: 70 – 80 °C (158 – 176 °F)

- Only use the COOL range on the dipstick as a rough reference when the fluid is replaced or the engine does not run.

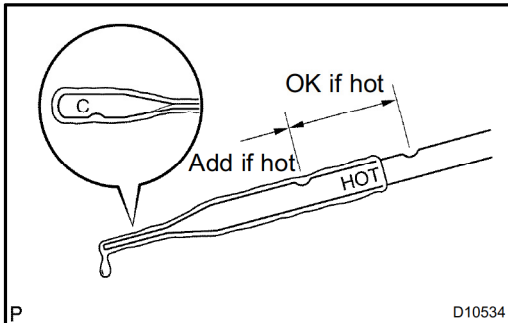

- (1) Park the vehicle on a level surface and set the parking brake.
- (2) With the engine idling and the brake pedal depressed, shift the shift lever into all positions from P to L position and return to P position.
- (3) Pull out the dipstick and wipe it clean.
- (4) Push it back fully into the pipe.
- (5) Pull it out and check that the fluid level is in the HOT range.

If the level is not within the range, add new fluid.

Fluid type: ATF TYPE T-IV

NOTICE:

Do not overfill.

(b) Check the fluid condition.

If the fluid smells burnt or is black, replace it.

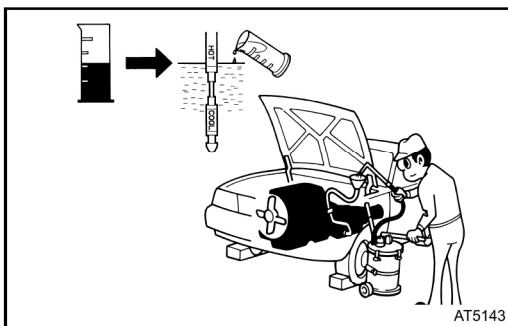

(c) Replace the ATF.

- (1) Remove the drain plug and drain the fluid.
- (2) Reinstall the drain plug securely.
- (3) With the engine OFF add new fluid through the oil filler pipe.

Fluid type: ATF TYPE T-IV

Capacity:

1.8 liters (1.9 US qts, 1.6 Imp. qts)

- (4) Start the engine and shift the shift lever into all positions from P to L position and then shift into P position.
- (5) With the engine idling, check the fluid level. Add fluid up to the COOL level on the dipstick.

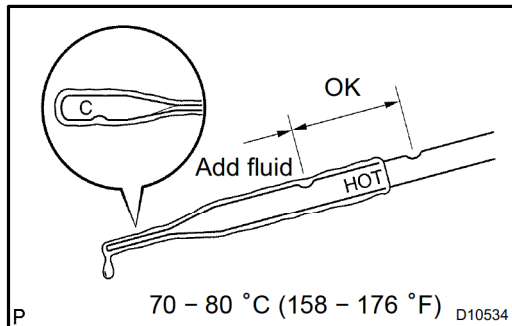

- (6) Check the fluid level is at the normal operating temperature, 70 - 80 °C (158 - 176 °F), and add as necessary.

NOTICE:**Do not overfill.**

- (d) Check the fluid leaks.

Check for leaks in the transmission.

If there are leaks, it is necessary to repair or replace O-rings, FIPGs, oil seals, plugs or other parts.

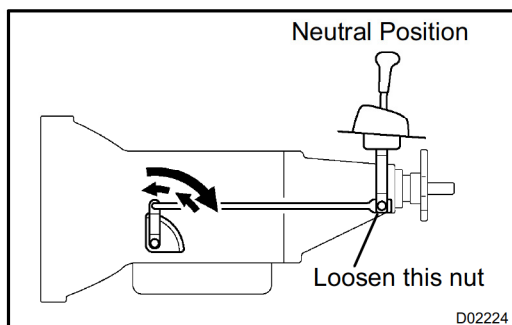

- (e) Inspect and adjust the shift lever position.

When shifting the shift lever from the N position to other positions, check that the lever can be shifted smoothly and accurately to each position and that the position indicator is aligned with the correct position.

If the indicator is not aligned with the correct position, carry out the following adjustment procedures.

- Loosen the nut on the shift lever.
- Push the control shaft fully rearward.
- Return the control shaft lever 2 notches to N position.
- Set the shift lever to N position.
- While holding the shift lever lightly toward the R position side, tighten the shift lever nut.

Torque: 13 N·m (130 kgf·cm, 10 ft·lbf)

- Start the engine and make sure that the vehicle moves forward when shifting the lever from the N to D position and reverses when shifting it to the R position.

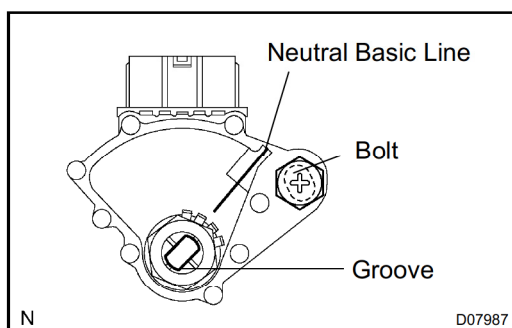

- (f) Inspect and adjust the park/neutral position switch.

- Check that the engine can be started with the shift lever only in the N or P position, but not in other positions.

If it is not as stated above, carry out the following adjustment procedures.

- Loosen the park/neutral position switch bolt and set the shift lever to the N position.
- Align the groove and neutral basic line.
- Hold the switch in position and tighten the bolt.

Torque: 13 N·m (130 kgf·cm, 10 ft·lbf)

- For continuity inspection of the park/neutral position switch, see page [DI-261](#).

- (g) Check the idle speed.

Idle speed (In N position and air conditioner OFF):
750 ± 50 rpm