

TAILLIGHT

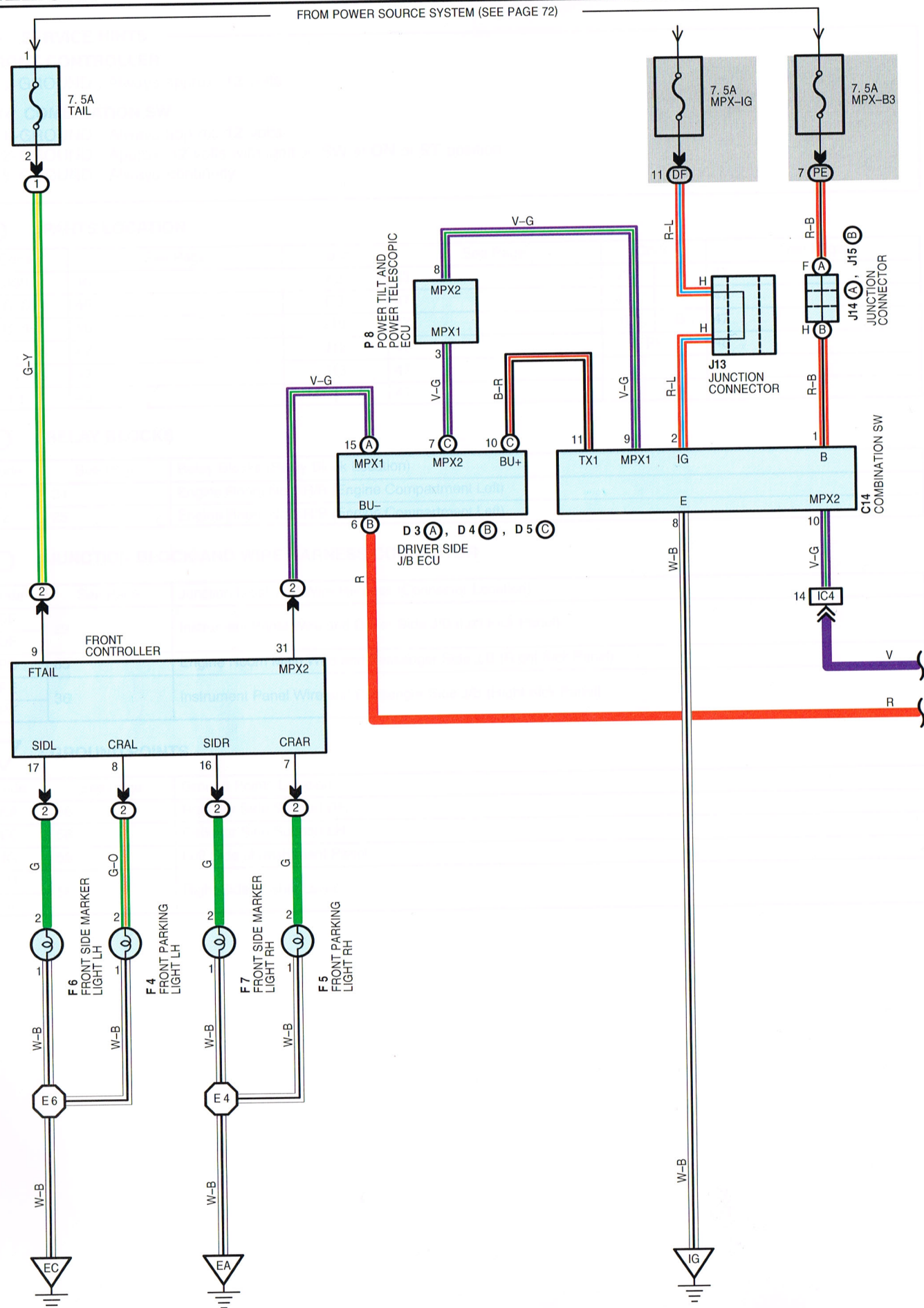

FROM POWER SOURCE SYSTEM (SEE PAGE 72)

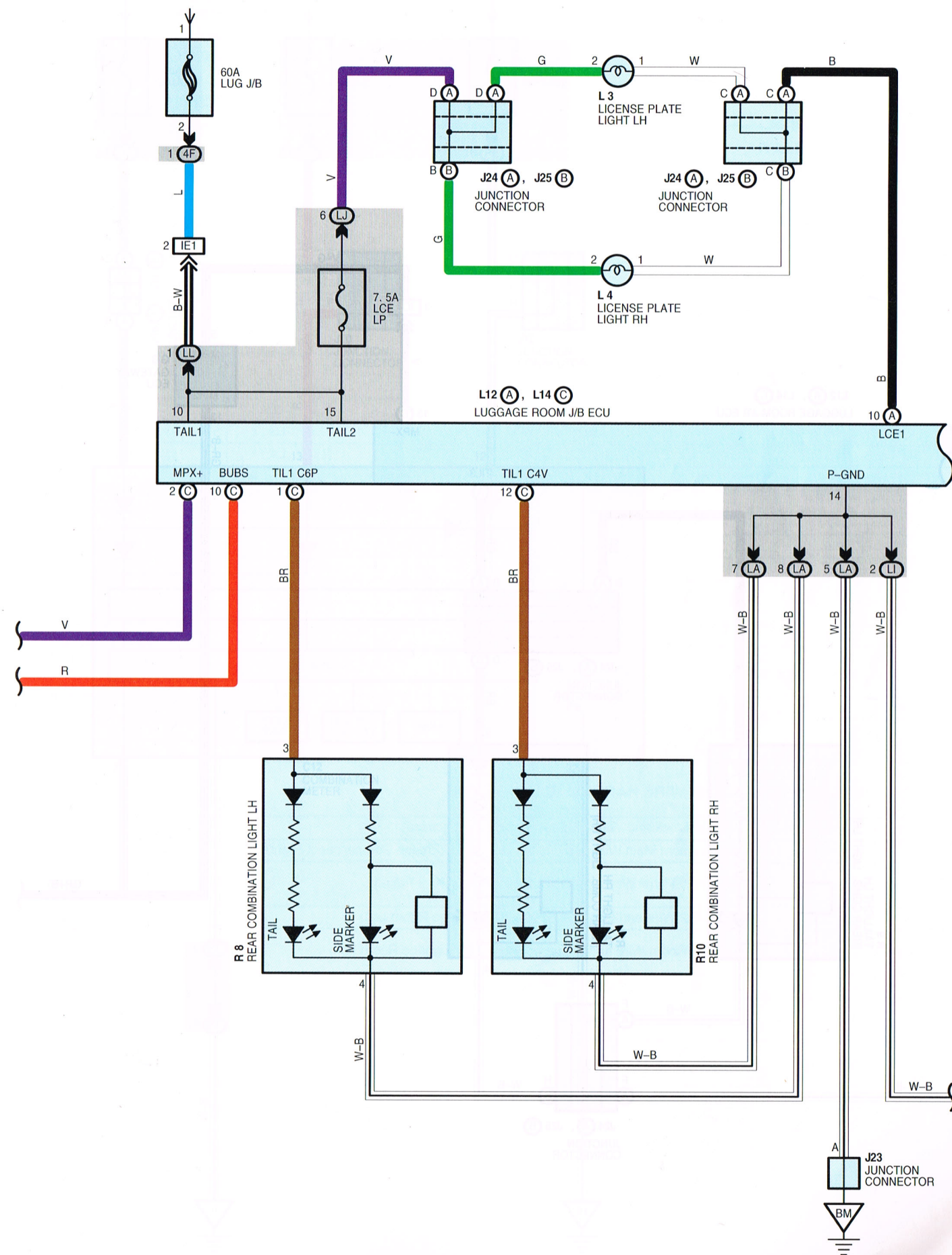

TAILLIGHT

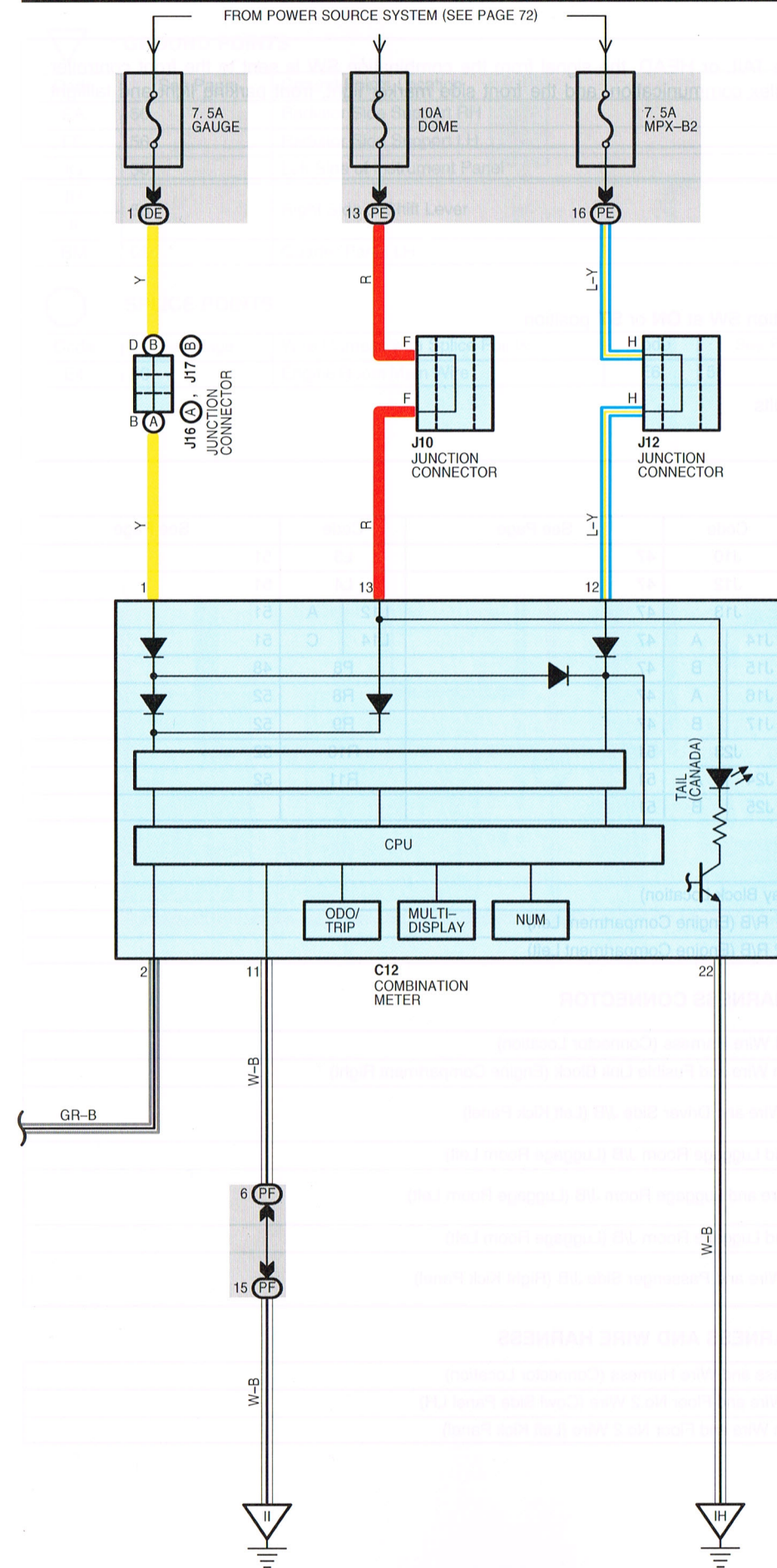
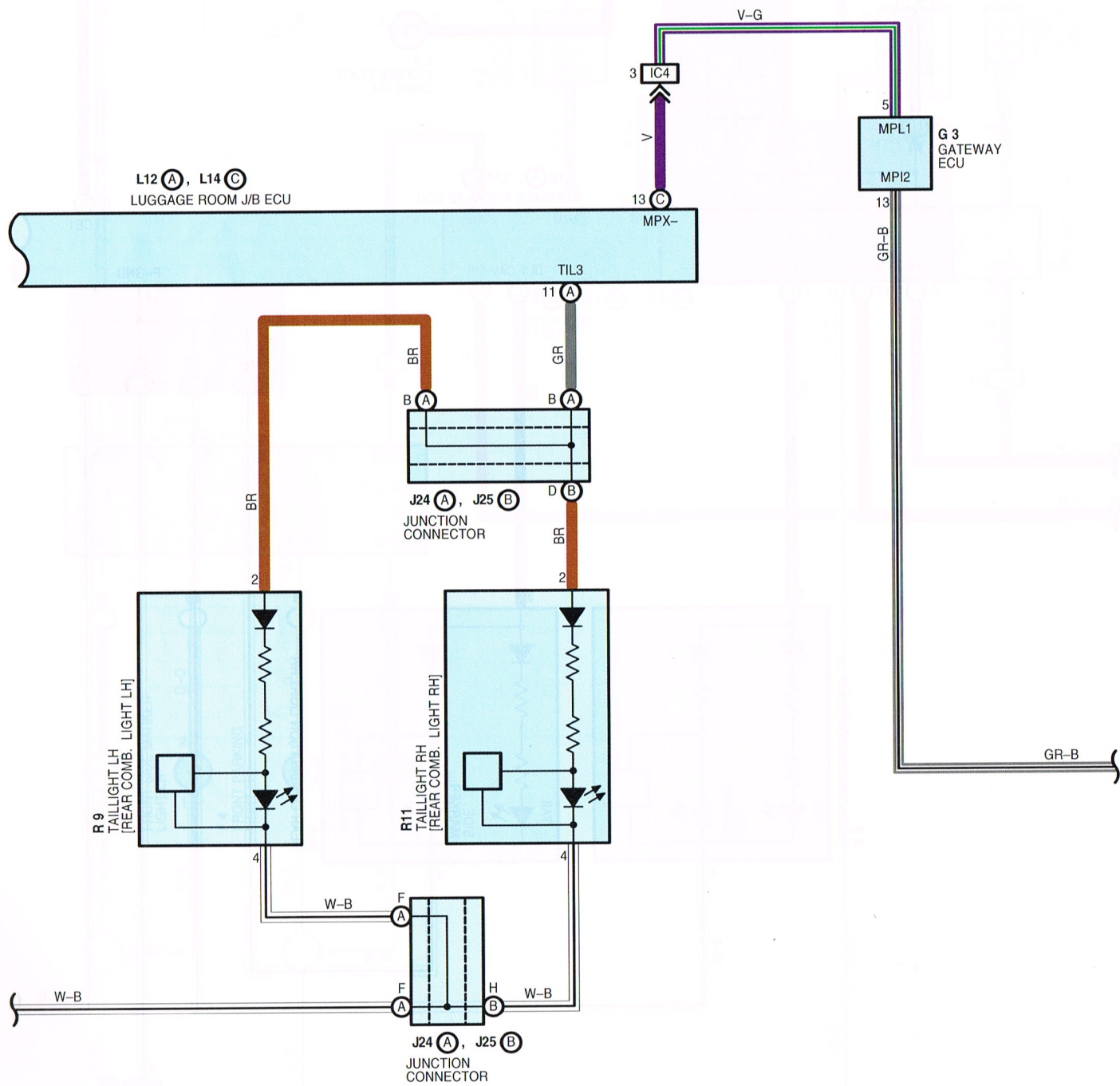

TAILLIGHT

SYSTEM OUTLINE

When the light control SW is turned to the TAIL or HEAD, the signal from the combination SW is sent to the front controller and luggage room J/B ECU by the multiplex communication, and the front side marker light, front parking light and taillight come on.

SERVICE HINTS

FRONT CONTROLLER

9-GROUND : Always approx. 12 volts

C14 COMBINATION SW

1-GROUND : Always approx. 12 volts

2-GROUND : Approx. 12 volts with ignition SW at ON or ST position

8-GROUND : Always continuity

LUGGAGE ROOM J/B ECU

10, 15-GROUND : Always approx. 12 volts

14-GROUND : Always continuity

○ : PARTS LOCATION

Code	See Page	Code	See Page	Code	See Page
C12	46	J10	47	L3	51
C14	46	J12	47	L4	51
D3	A 47	J13	47	L12	A 51
D4	B 47	J14	A 47	L14	C 51
D5	C 47	J15	B 47	P8	48
F4	43	J16	A 47	R8	52
F5	43	J17	B 47	R9	52
F6	43	J23	51	R10	52
F7	43	J24	A 51	R11	52
G3	47	J25	B 51		

○ : RELAY BLOCKS

Code	See Page	Relay Blocks (Relay Block Location)
1	24	Engine Room No.1 R/B (Engine Compartment Left)
2	25	Engine Room No.2 R/B (Engine Compartment Left)

○ : JUNCTION BLOCK AND WIRE HARNESS CONNECTOR

Code	See Page	Junction Block and Wire Harness (Connector Location)
4F	27	Engine Room Main Wire and Fusible Link Block (Engine Compartment Right)
DE	29	Instrument Panel Wire and Driver Side J/B (Left Kick Panel)
DF		
LA	40	Floor No.2 Wire and Luggage Room J/B (Luggage Room Left)
LI	40	Luggage Room Wire and Luggage Room J/B (Luggage Room Left)
LJ		
LL	40	Floor No.2 Wire and Luggage Room J/B (Luggage Room Left)
PE	36	Instrument Panel Wire and Passenger Side J/B (Right Kick Panel)
PF		

□ : CONNECTOR JOINING WIRE HARNESS AND WIRE HARNESS

Code	See Page	Joining Wire Harness and Wire Harness (Connector Location)
IC4	58	Instrument Panel Wire and Floor No.2 Wire (Cowl Side Panel LH)
IE1	58	Engine Room Main Wire and Floor No.2 Wire (Left Kick Panel)

▽ : GROUND POINTS

Code	See Page	Ground Points Location
EA	56	Radiator Side Support RH
EC	56	Radiator Side Support LH
IG	58	Left Side of Instrument Panel
IH	58	Right Side of Shift Lever
II		
BM	62	Quarter Panel LH

○ : SPLICE POINTS

Code	See Page	Wire Harness with Splice Points	Code	See Page	Wire Harness with Splice Points
E4	56	Engine Room Main Wire	E6	56	Engine Room Main Wire