

FRONT WHEEL ALIGNMENT

ADJUSTMENT

260GW-01

1. INSPECT TIRE (SEE PAGE 28-1)

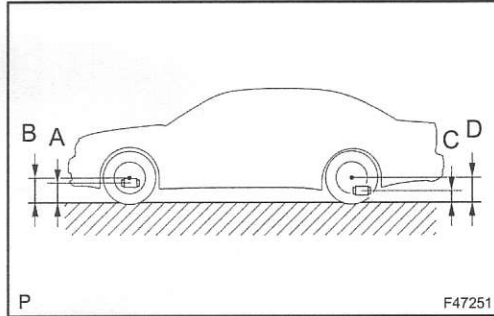

2. MEASURE VEHICLE HEIGHT

Vehicle height:

Except air suspension:

Tire Size	Front B-A	Rear D-C
P225/55R17	105 mm (4.13 in.)	91 mm (3.58 in.)
245/45R18	104 mm (4.09 in.)	89 mm (3.50 in.)

Air suspension:

Front B-A	Rear D-C
115 mm (4.53 in.)	109 mm (4.29 in.)

Measuring points:

A: Ground clearance of lower suspension arm No.1 bushing set bolt center

B: Ground clearance of front wheel center

C: Ground clearance of rear suspension arm No.2 set bolt center

D: Ground clearance of rear wheel center

NOTICE:

Before inspecting the wheel alignment, adjust the vehicle height to the specified value.

HINT:

Bounce the vehicle up and down to stabilize the suspension and inspect the vehicle height.

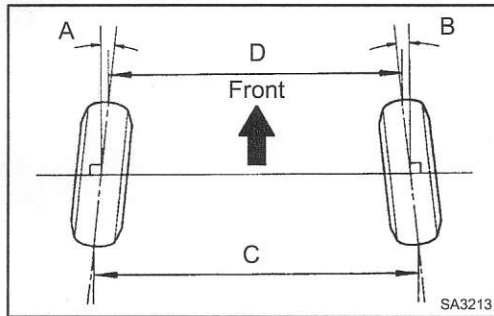

3. INSPECT TOE-IN

Toe-in:

Toe-in (total)	A + B: $0^{\circ}06' \pm 12'$ ($0.1^{\circ} \pm 0.2^{\circ}$) C - D: 1 ± 2 mm (0.04 ± 0.08 in.)
----------------	---

If the toe-in is not within the specified range, adjust it at the rack ends.

4. ADJUST TOE-IN

- Remove the rack boot set clips.
- Loosen the tie rod end lock nuts.

- Turn the right and left rack ends by equal amounts to adjust the toe-in.

HINT:

Try to adjust the toe-in to the center of the specified value.

- Make sure that the lengths of the right and left rack ends are the same.

- Torque the tie rod end lock nuts.

Torque: 56 N·m (570 kgf·cm, 41 ft·lbf)

- Place the boots on the seats and install the clips.

