

## VALVE BODY ASSEMBLY ON-VEHICLE REPAIR

AT037-01

### CAUTION:

When working with FIPG material, you must observe the following items.

- Using a razor blade and gasket scraper, remove all the old FIPG material from the gasket surfaces.
- Thoroughly clean all components to remove all the loose material.
- Clean both sealing surfaces with a non-residue solvent.
- Apply FIPG in an approx. 1 mm (0.04 in.) wide bead along the sealing surface.
- Parts must be assembled within 10 minutes of application. Otherwise, the FIPG material must be removed and reapplied.

### 1. REMOVE DRAIN PLUG WITH GASKET AND DRAIN ATF

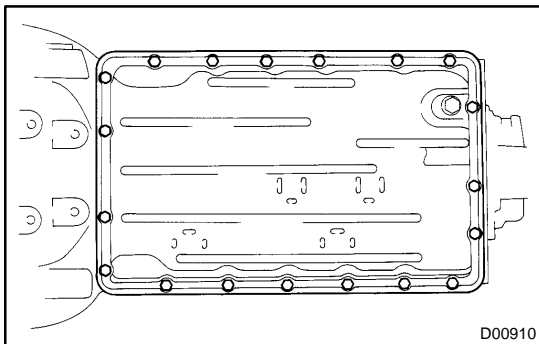

### 2. REMOVE OIL PAN

#### NOTICE:

Some fluid will remain in the oil pan.

- (a) Remove the 19 bolts.

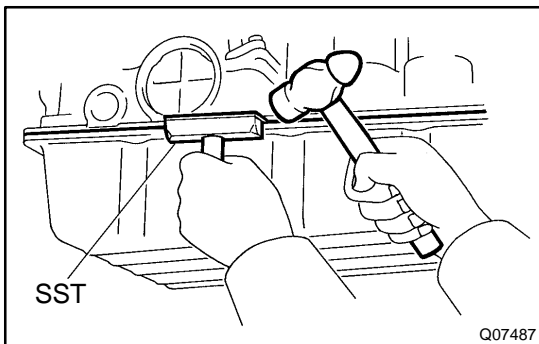

- (b) Install the blade of SST between the transmission case on oil pan, cut off applied sealer, and remove the oil pan.  
SST 09032 – 00100

#### NOTICE:

When removing the oil pan, be careful not to damage the oil pan flange.

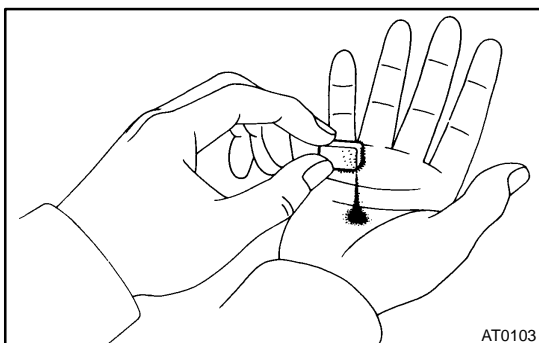

### 3. EXAMINE PARTICLES IN PAN

Remove the magnets and use them to collect steel particles. Carefully look at the foreign matter and particles in the pan and on the magnets to anticipate the type of wear you will find in the transmission.

Steel (magnetic) ... bearing, gear and clutch plate wear  
Brass (non-magnetic) ... bushing wear

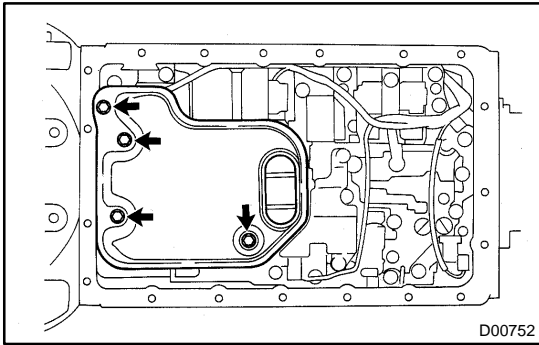

**4. REMOVE OIL STRAINER**

**NOTICE:**

**Be careful as some fluid will come out of the oil strainer.**

- (a) Remove the 4 bolts and oil strainer.

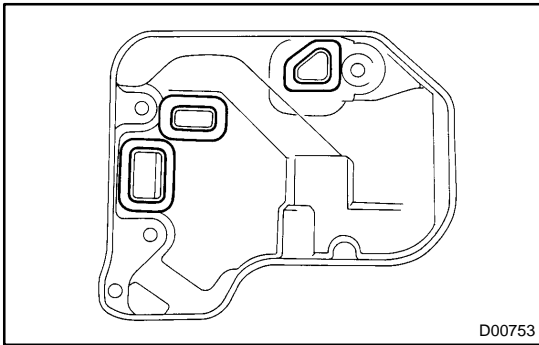

- (b) Remove the 3 gaskets from the oil strainer.

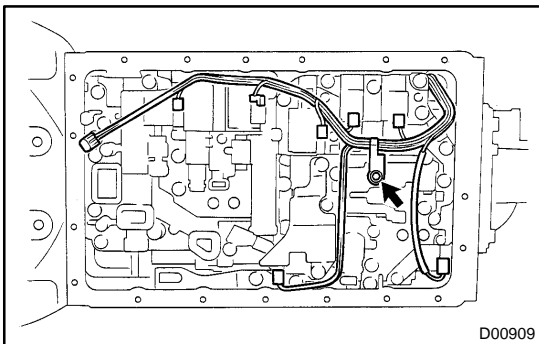

**5. REMOVE SOLENOID WIRING**

- (a) Disconnect the ATF temperature sensor.
- (b) Remove the bolt and clamp.
- (c) Disconnect the 7 connectors from the solenoid valves.

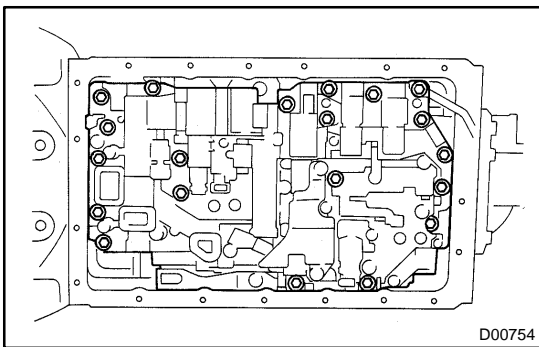

**6. REMOVE VALVE BODY**

- (a) Remove the 21 bolts and valve body.

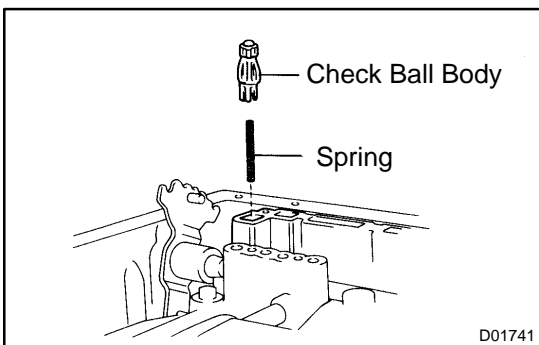

**7. REMOVE CHECK BALL BODY AND SPRING**

**NOTICE:**

**Do not drop the check ball body and spring.**

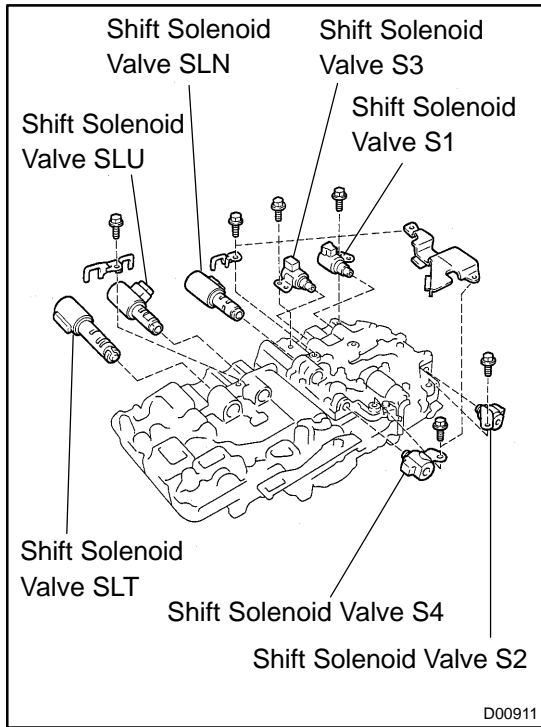

**8. REMOVE SOLENOID VALVE**

- (a) Remove the 3 bolts and shift solenoid valve No.1, No.2 and No.3.
- (b) Remove the 2 bolts, oil guide plate, lock plate, shift solenoid valve SLN and No.4.
- (c) Remove the 6 O-rings from each shift solenoid valve.
- (d) Remove the bolt, lock plate and shift solenoid valve SLU and SLT.

**9. INSTALL SOLENOID VALVE**

- (a) Install the shift solenoid valve SLU and SLT and the lock plate with the bolt.

**Torque: 6.4 N·m (65 kgf·cm, 56 in.-lbf)**

- (b) Coat 6 new O-rings with ATF.
- (c) Install the 6 O-rings to the each solenoid valve.
- (d) Install the shift solenoid valve SLN, No.4, lock plate and oil guide plate with the 2 bolts.

**Torque: 10 N·m (100 kgf·cm, 7 ft·lbf)**

- (e) Install the shift solenoid valve No.1, No.2 and No.3 with the 3 bolts.

**Torque:**

**Shift solenoid valve No.1 and No.3:**

**6.4 N·m (65 kgf·cm, 56 in.-lbf)**

**Shift solenoid valve No.2:**

**10 N·m (100 kgf·cm, 7 ft·lbf)**

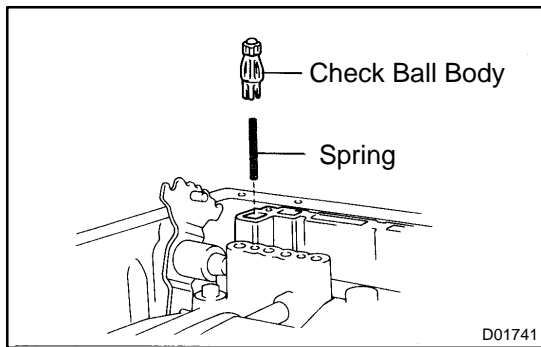

**10. INSTALL CHECK BALL BODY AND SPRING**

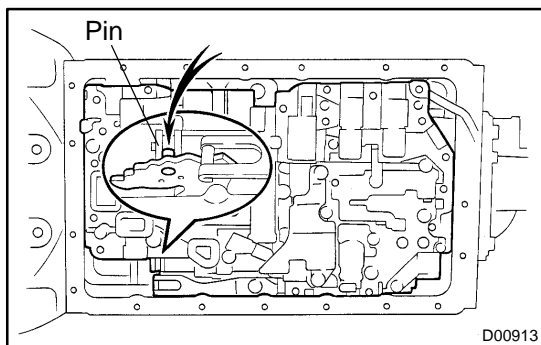

**11. INSTALL VALVE BODY**

- (a) Align the groove of the manual valve to pin of the lever.

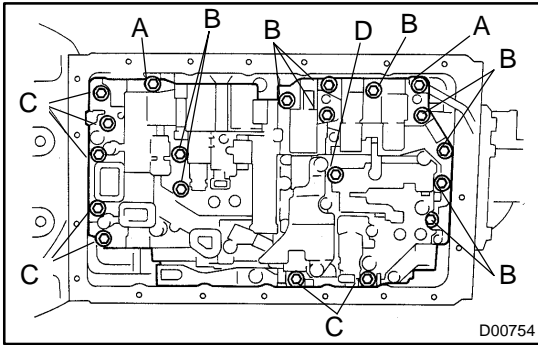

- (b) Install the 21 bolts.  
**Torque: 10 N·m (100 kgf-cm, 7 ft-lbf)**  
**Bolt length:**  
**Bolt A: 23 mm (0.91 in.)**  
**Bolt B: 28 mm (1.10 in.)**  
**Bolt C: 36 mm (1.42 in.)**  
**Bolt D: 55 mm (2.17 in.)**

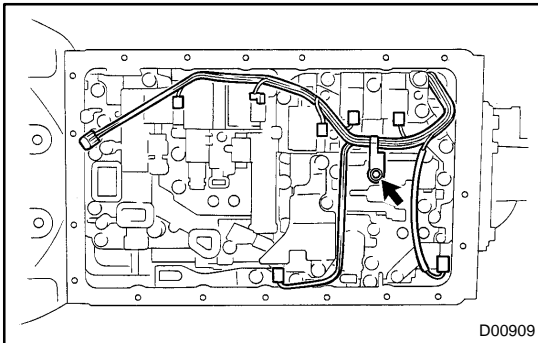

- 12. INSTALL SOLENOID WIRING**  
 (a) Connect the 7 connectors to the solenoid valves.  
 (b) Install the clamp with the bolt.  
**Torque: 6.4 N·m (65 kgf-cm, 56 in.-lbf)**  
 (c) Connect the ATF temperature sensor.

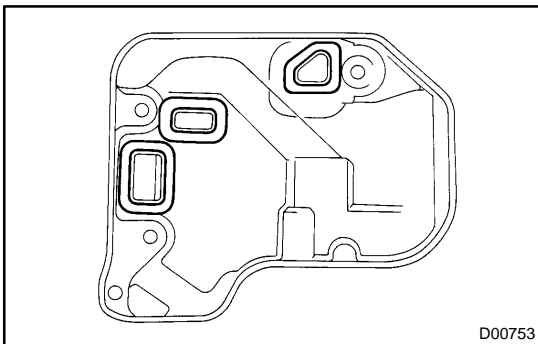

- 13. INSTALL OIL STRAINER**  
 (a) Install 3 new gaskets.

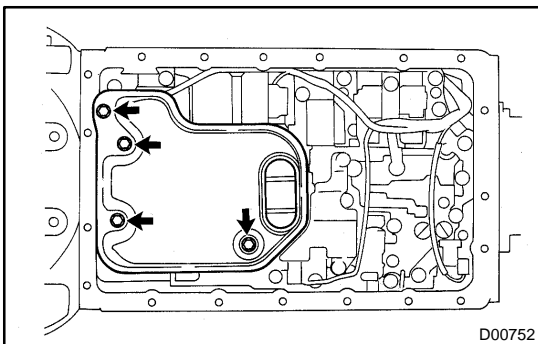

- (b) Install the oil strainer with the 4 bolts.  
**Torque: 10 N·m (100 kgf-cm, 7 ft-lbf)**

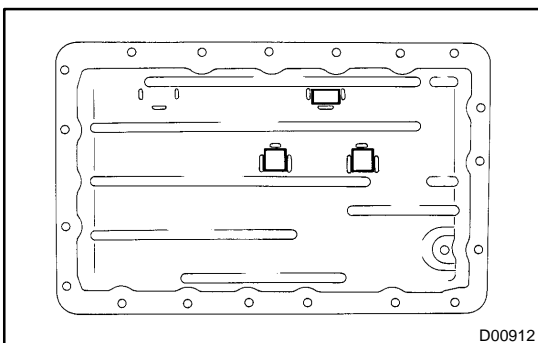

- 14. INSTALL OIL PAN**  
 (a) Install the 3 magnets in the indications of the oil pan.

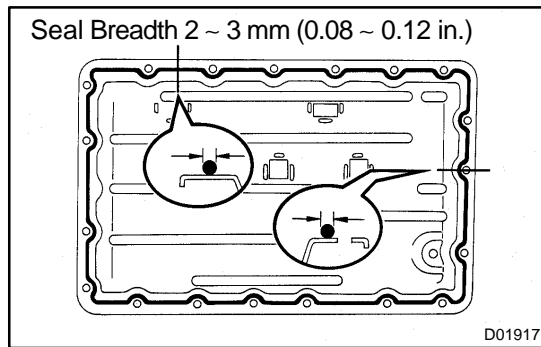

(b) Remove any packing material and be careful not to drop oil on the contacting surfaces of the transmission case and oil pan.

(c) Apply FIPG to the oil pan.

**FIPG:**

**Part No. 08826 – 00090, THREE BOND 1281 or equivalent**

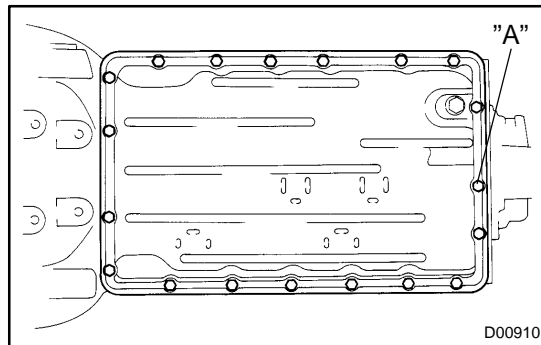

(d) Install the oil pan with the 19 bolts.

**Torque: 7.4 N·m (75 kgf·cm, 65 in.-lbf)**

**HINT:**

Replace the only "A" bolt with a new one.

**15. INSTALL DRAIN PLUG WITH NEW GASKET**

**Torque: 20 N·m (205 kgf·cm, 15 ft·lbf)**

**16. FILL FLUID AND CHECK FLUID**

(See page [DI-172](#))