

SFI SYSTEM PRECAUTION

SF0EP-02

1. BEFORE WORKING ON FUEL SYSTEM, DISCONNECT NEGATIVE (-) TERMINAL CABLE FROM BATTERY

HINT:

Any diagnostic trouble code retained by the computer will be erased when the negative (-) terminal cable is removed from the battery.

Therefore, if necessary, read the diagnosis before disconnecting the negative (-) terminal cable from the battery.

2. DO NOT SMOKE OR WORK NEAR AN OPEN FLAME WHEN WORKING ON FUEL SYSTEM

3. KEEP GASOLINE AWAY FROM RUBBER OR LEATHER PARTS

4. MAINTENANCE PRECAUTIONS

(a) In event of the engine misfire, following the precautions should be taken.

- (1) Check proper connection of battery terminals, etc.
- (2) After repair work, check that the ignition coil terminals and all other ignition system lines are reconnected securely.
- (3) When cleaning the engine compartment, be especially careful to protect the electrical system from water.

(b) Precautions when handling the oxygen sensor.

- (1) Do not allow oxygen sensor to drop or hit against an object.
- (2) Do not allow the sensor to come into contact with water.

5. IF VEHICLE IS EQUIPPED WITH MOBILE RADIO SYSTEM (HAM, CB, ETC.)

If the vehicle is equipped with a mobile communication system, refer to the precaution in the IN section.

6. AIR INDUCTION SYSTEM

- (a) Separation of the engine oil dipstick, oil filler cap, PCV hose, etc. may cause the engine to run out of tune.
- (b) Disconnection, looseness or cracks in the parts of the air induction system between the throttle body and cylinder head will allow air suction and cause the engine to run out of tune.

7. ELECTRONIC CONTROL SYSTEM

- (a) Before removing SFI wiring connectors, terminals, etc., first disconnect the power by either turning the ignition switch OFF or disconnecting the negative (-) terminal cable from the battery.

HINT:

Always check the diagnostic trouble code before disconnecting the negative (-) terminal cable from the battery.

- (b) When installing the battery, be especially careful not to incorrectly connect the positive (+) and negative (-) cables.
- (c) Do not permit parts to receive a severe impact during removal or installation. Handle all SFI parts carefully, especially the ECM.
- (d) Do not be careless during troubleshooting as there are numerous transistor circuits and even slight terminal contact can further troubles.
- (e) Do not open the ECM cover.

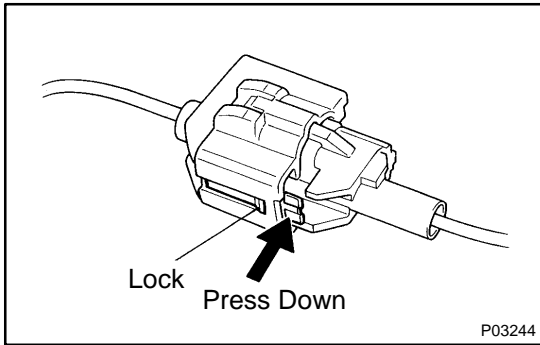

- (f) When inspecting during rainy weather, take care to prevent entry of water. Also, when washing the engine compartment, prevent water from getting on the SFI parts and wiring connectors.
- (g) Parts should be replaced as an assembly.
- (h) Care is required when pulling out and inserting wiring connectors.
- (i) Release the lock and pull out the connector, pulling on the connectors.

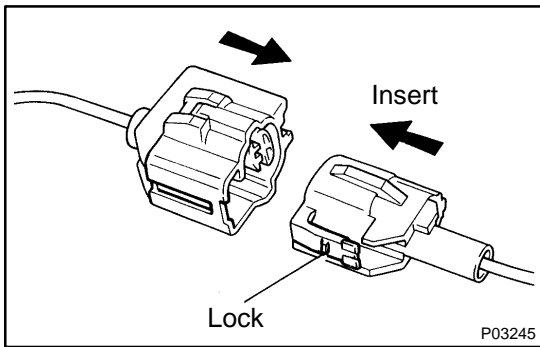

- (j) Fully insert the connector and check that it is locked.
- (k) When inspecting a connector with a volt/ohmmeter
- (l) Carefully take out the water-proofing rubber if it is a water-proof type connector.
- (m) Insert the test probe into the connector from the wiring side when checking the continuity, amperage or voltage.
- (n) Do not apply unnecessary force to the terminal.
- (o) After checking, install the water-proofing rubber on the connector securely.

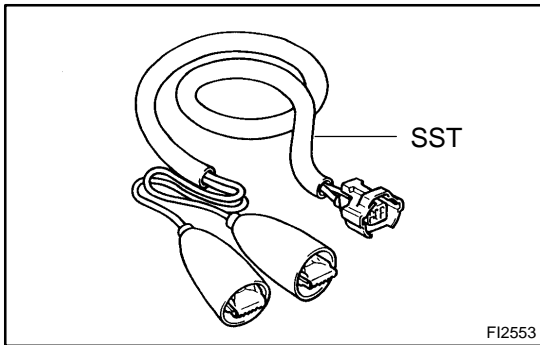

- (p) Use SST for inspection or test of the injector or its wiring connector.
SST 09842-30070

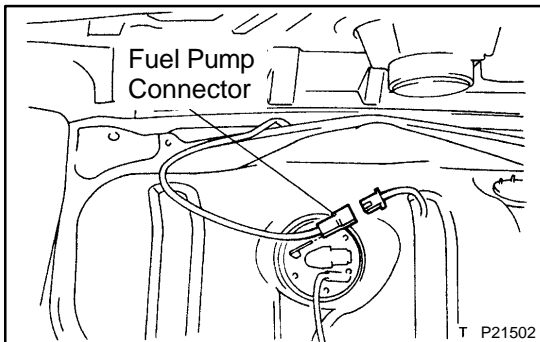

8. FUEL SYSTEM

- (a) When disconnecting the high fuel pressure line, a large amount of gasoline will spill out, so observe the following procedures:
 - (1) Disconnect the fuel pump connector.
 - (2) Start the engine. After the engine has stopped on its own, turn the ignition switch OFF.

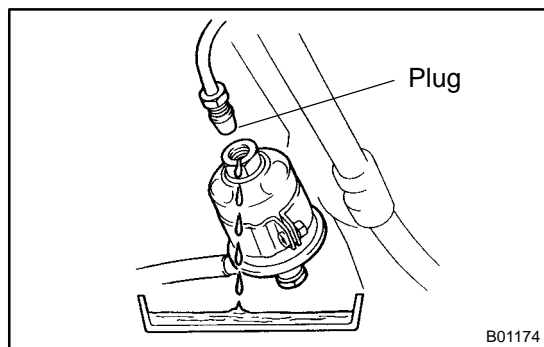

- (3) Put a container under the connection.
- (4) Slowly loosen the connection.
- (5) Disconnect the connection.
- (6) Plug the connection with a rubber plug.
- (7) Reconnect the fuel pump connector.

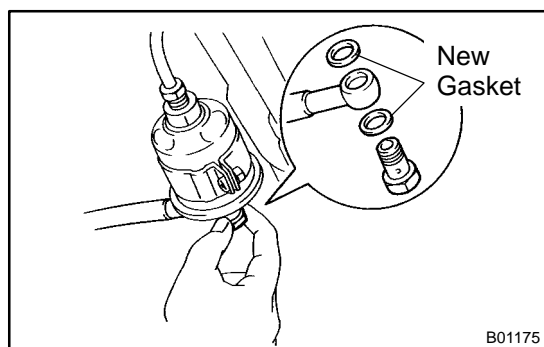

- (b) When connecting the flare nut on the high pressure pipe union, observe these procedures:
 - (1) Always use a new gasket.
 - (2) Tighten the union bolt by hand.
 - (3) Tighten the union bolt to the specified torque.

Torque: 29 N·m (300 kgf·cm, 21 ft·lbf)

- (c) When connecting the union bolt on the high pressure pipe union, observe these procedures:

- (1) Apply a light coat of engine oil to the flare and tighten the flare nut by hand.
- (2) Using SST, tighten the flare nut to the specified torque.

SST 09631-22020

NOTICE:

Do not rotate the fuel pipe, when tightening the flare nut.

Torque: 31 N·m (310 kgf·cm, 23 ft·lbf)

HINT:

Use a torque wrench with a fulcrum length of 30 cm (11.81 in.)

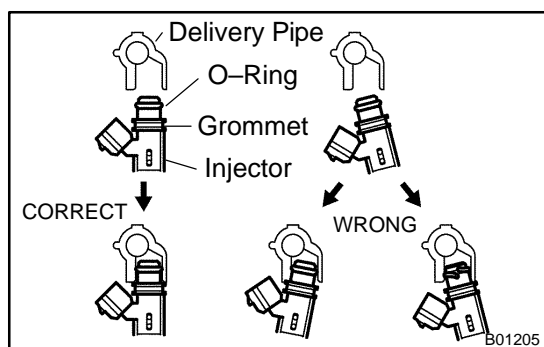
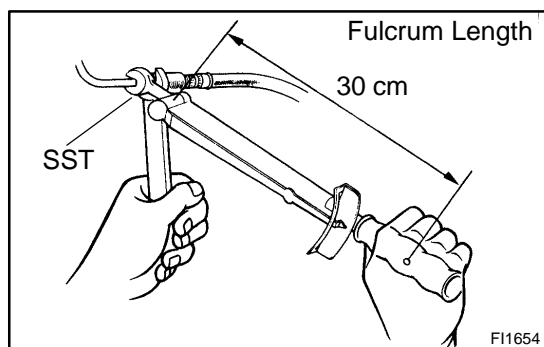

- (d) Observe these precautions when removing and installing the injectors.

- (1) Never reuse the O-ring.
- (2) When placing a new O-ring on the injector, take care not to damage it in any way.
- (3) Coat a new O-ring with spindle oil or gasoline before installing—never use engine, gear or brake oil.

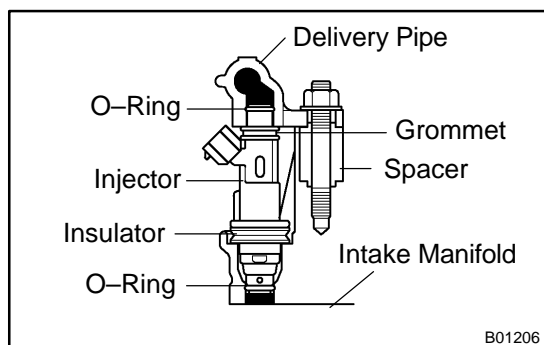

- (e) Install the injector to the delivery pipe and intake manifold as shown in the illustration.

Before installing the injector must apply spindle oil or gasoline on the place where a delivery pipe or an intake manifold touches an O-ring of the injector.

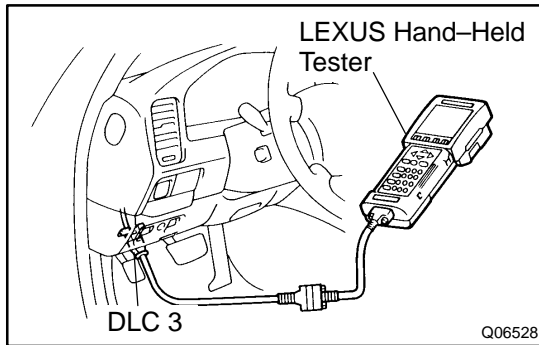

- (f) Check that there are no fuel leaks after doing maintenance anywhere on the fuel system.
- (1) Connect a LEXUS hand-held tester to the DLC3.
 - (2) Turn the ignition switch ON, and push the LEXUS hand-held tester main switch ON.

NOTICE:

Do not start the engine.

- (3) Select the active test mode on the LEXUS hand-held tester.
- (4) Please refer to the LEXUS hand-held tester operator's manual for further details.
- (5) If you have no LEXUS hand-held tester, connect the positive (+) and negative (-) leads from the battery to the fuel pump connector.
(See page [SF-5](#))

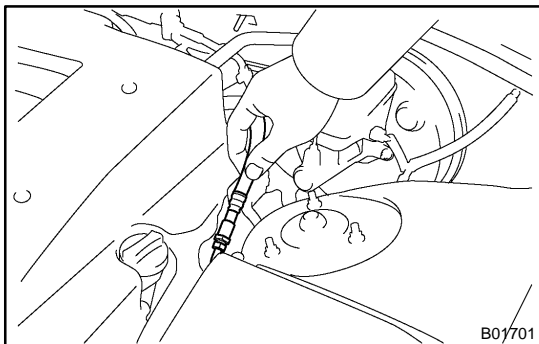

- (6) Pinch the fuel inlet hose.
The pressure in the high pressure line will rise to approx. 392 kPa (4 kgf/cm², 57 psi). In this state, check to see that there are no leaks from any part of the fuel system.

NOTICE:

Always pinch the hose. Avoid bending as it may cause the hose to crack.

- (7) Turn the ignition switch OFF.
- (8) Disconnect the LEXUS hand-held tester from the DLC3.

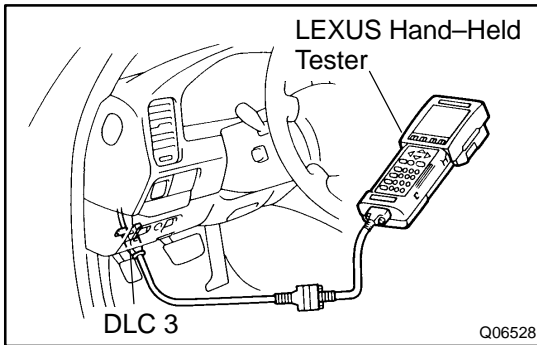

FUEL PUMP ON-VEHICLE INSPECTION

SFOEQ-02

1. CHECK FUEL PUMP OPERATION

- (a) Connect a LEXUS hand-held tester to the DLC3.
- (b) Turn the ignition switch ON, and push the LEXUS hand-held tester main switch ON.

NOTICE:

Do not start the engine.

- (c) Select the active test mode on the LEXUS hand-held tester.
- (d) Please refer to the LEXUS hand-held tester operator's manual for further details.

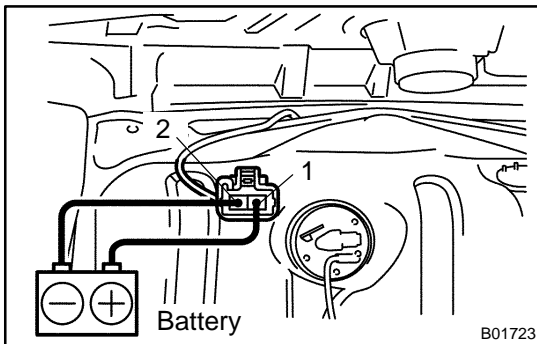

- (e) If you have no LEXUS hand-held tester, connect the positive (+) lead from the battery to terminal 1 of the connector, and the negative (-) lead to terminal 2.

NOTICE:

- ◆ These test must be done quickly (within 10 seconds) to prevent the coil from burning out.
- ◆ Keep the fuel pump as far away from the battery as possible.
- ◆ Always do the switching at the battery side.

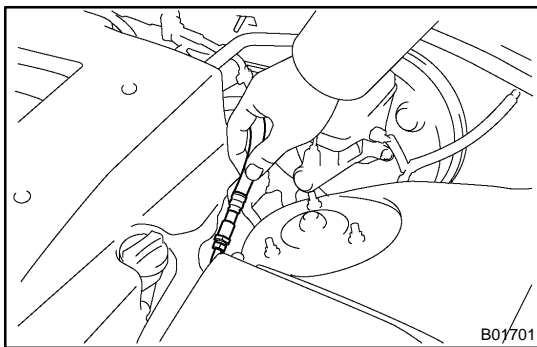

- (f) Check that there is pressure in the fuel inlet hose.

HINT:

If there is fuel pressure, you will hear the sound of fuel flowing.

If there is no pressure, check these parts:

- ◆ Fusible link
- ◆ Fuses
- ◆ EFI main relay
- ◆ Fuel pump
- ◆ Fuel pump relay
- ◆ Fuel pump resistor
- ◆ ECM
- ◆ Wiring connections

- (g) Turn the ignition switch OFF.
- (h) Disconnect the LEXUS hand-held tester from the DLC3.

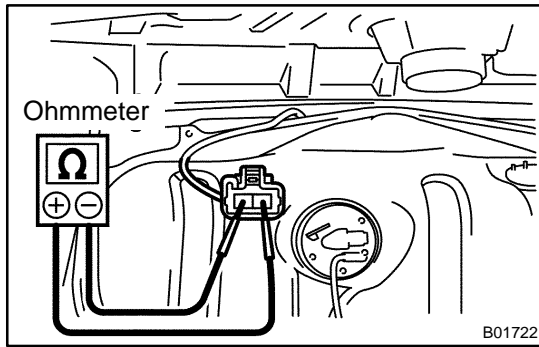

2. INSPECT FUEL PUMP RESISTANCE

Using an ohmmeter, measure the resistance between the terminals.

Resistance: 0.2 – 3.0 Ω at 20°C (68°F)

If the resistance is not as specified, replace the fuel pump and/or set plate.

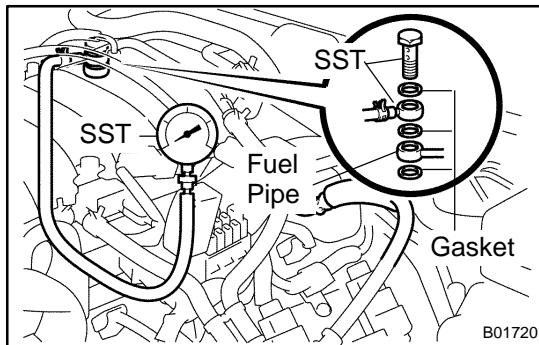

3. CHECK FUEL PRESSURE

- Check the battery positive voltage is above 12 V.
- Disconnect the negative (–) terminal cable from the battery.
- Remove the RH fuel pressure pulsation damper (See page SF-28).
- Install the fuel inlet hose and SST (pressure gauge) to the delivery pipe with 3 lower gaskets and the SST (union bolt).
SST 09268-45014 (09268-41190, 90405-06167)
Torque: 39 N·m (400 kgf·cm, 29 ft·lbf)
- Wipe off any splattered gasoline.

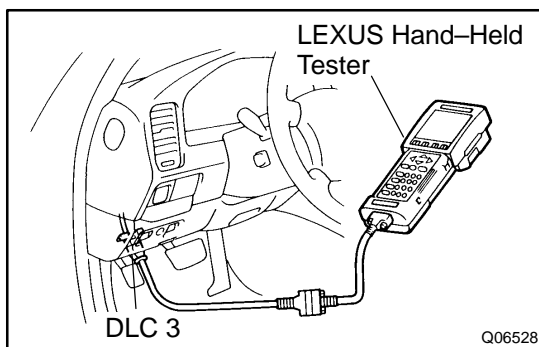

- Connect the LEXUS hand-held tester to the DLC3. (See step 1. (a) to (e) above)
- Reconnect the negative (–) terminal cable to the battery.
- Turn the ignition switch ON.
- Measure the fuel pressure.

Fuel pressure:

304 – 343 kPa (3.1 – 3.5 kgf/cm², 44 – 50 psi)

If pressure is high, replace the fuel pressure regulator.

If pressure is low, check these parts:

- ◆ Fuel hoses and connections
- ◆ Fuel pump
- ◆ Fuel filter
- ◆ Fuel pressure regulator

- Remove the LEXUS hand-held tester from the DLC3.
- Start the engine.
- Measure the fuel pressure at idle.

Fuel pressure:

304 – 343 kPa (3.1 – 3.5 kgf/cm², 44 – 50 psi)

If pressure is not as specified, check the vacuum sensing hose and fuel pressure regulator.

- (m) Stop the engine.
- (n) Check that the fuel pressure remains as specified for 5 minutes after the engine has stopped.

Fuel pressure:**147 kPa (1.5 kgf/cm², 21 psi) or more**

If pressure is not as specified, check the fuel pump, pressure regulator and/or injectors.

- (o) After checking fuel pressure, disconnect the negative (-) terminal cable from the battery and carefully remove the SST to prevent gasoline from splashing.
SST 09268-45012
- (p) Reinstall the fuel pressure pulsation damper
(See page [SF-29](#)).
- (q) Reconnect the negative (-) terminal cable to the battery.
- (r) Check for fuel leaks. (See page [SF-1](#))

COMPONENTS

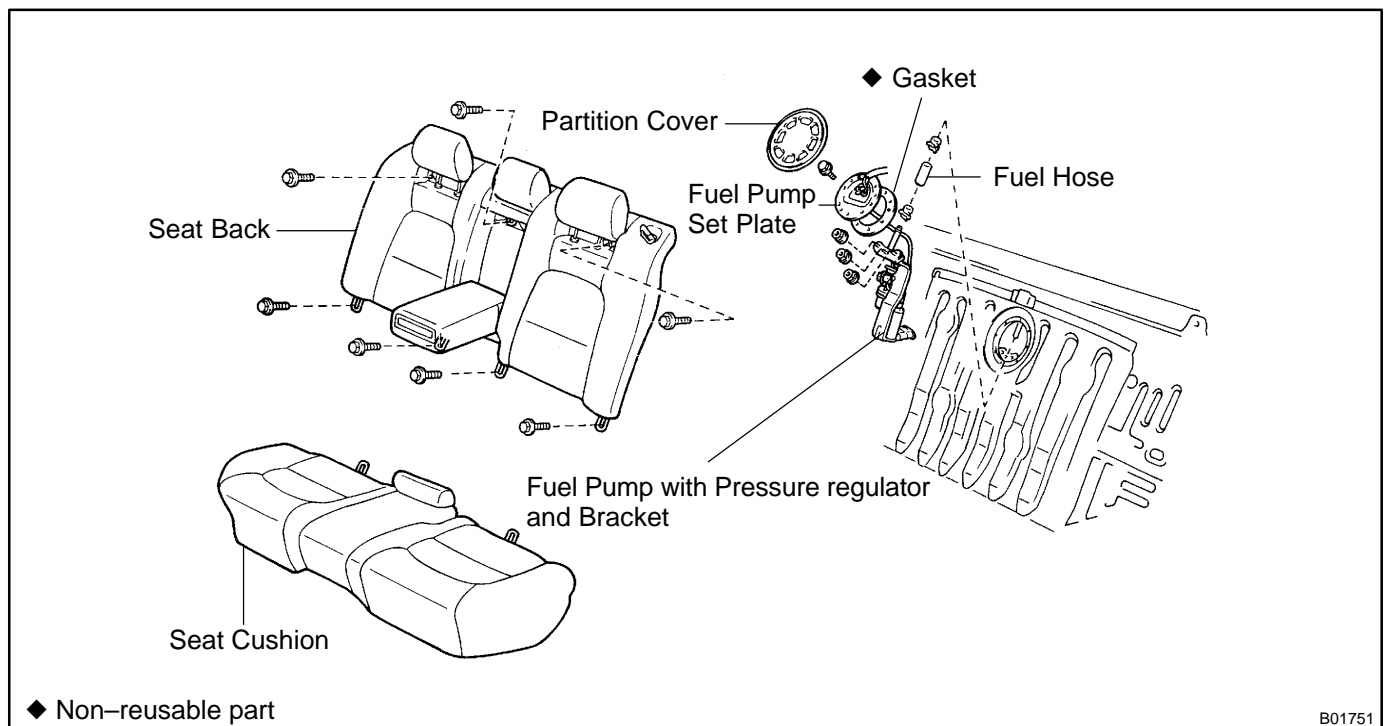
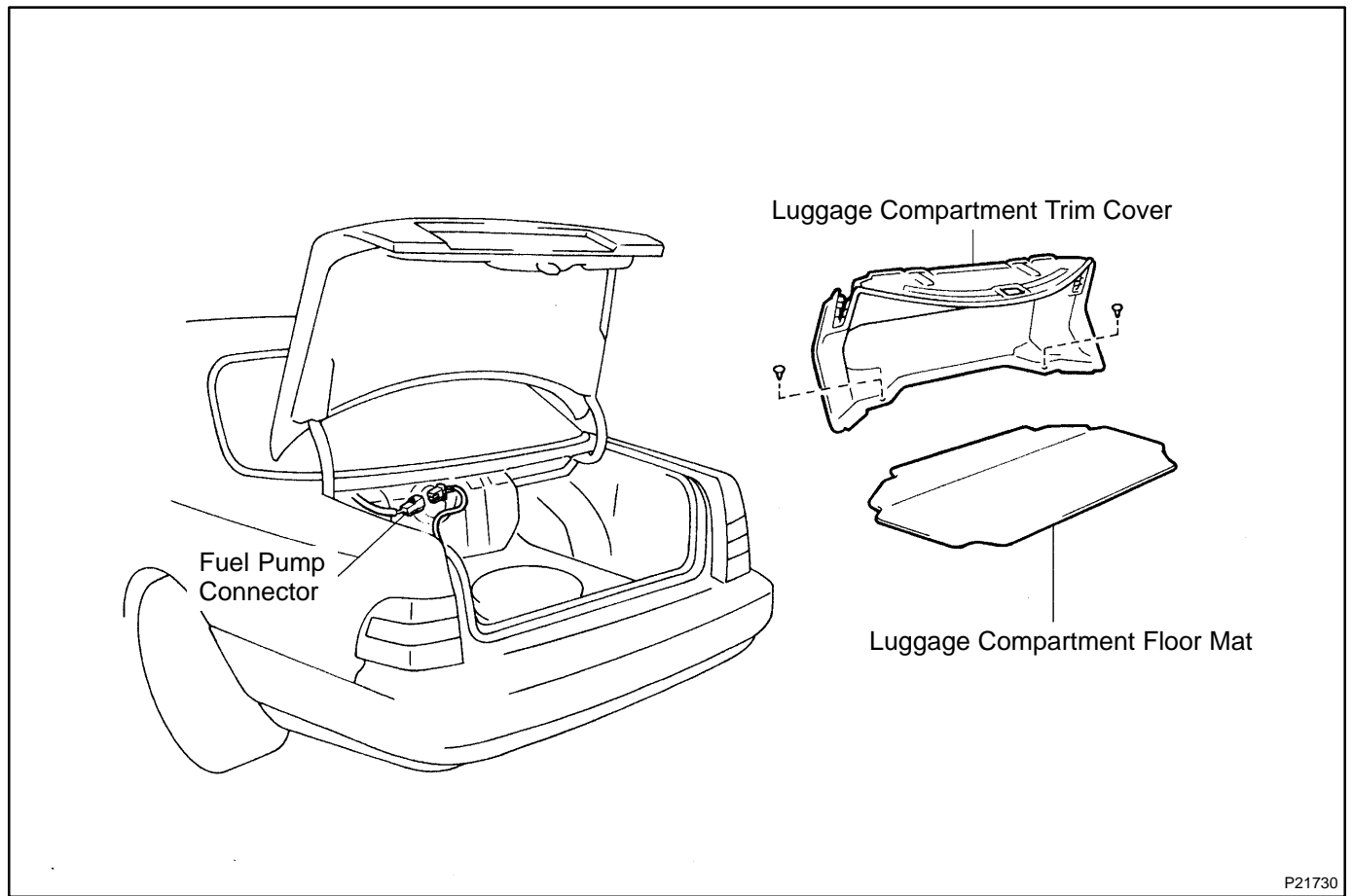

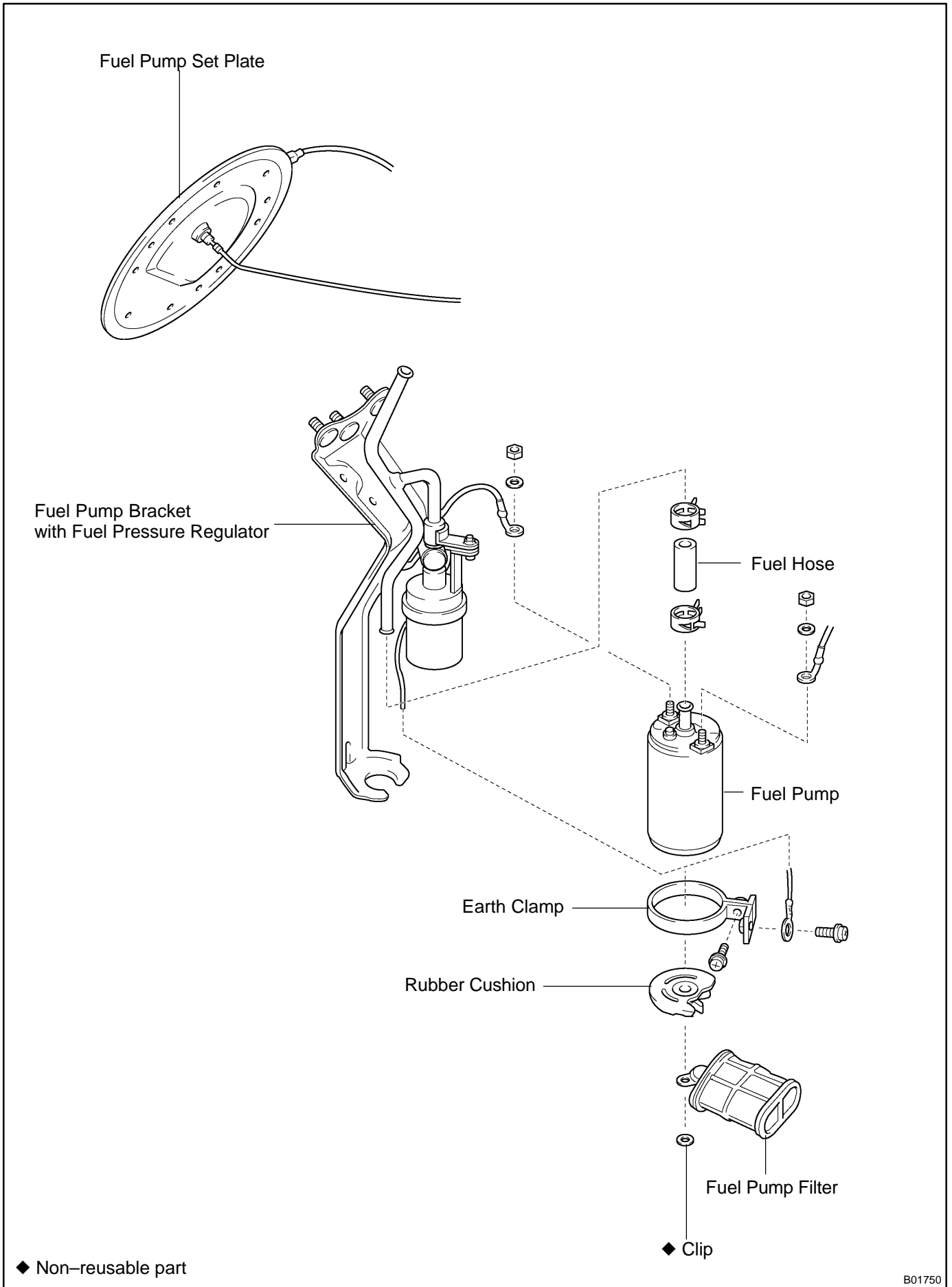

B01750

REMOVAL

CAUTION:

Do not smoke or work near an open flame when working on the fuel pump.

1. REMOVE LUGGAGE COMPARTMENT FLOOR MAT
2. REMOVE LUGGAGE COMPARTMENT TRIM COVER

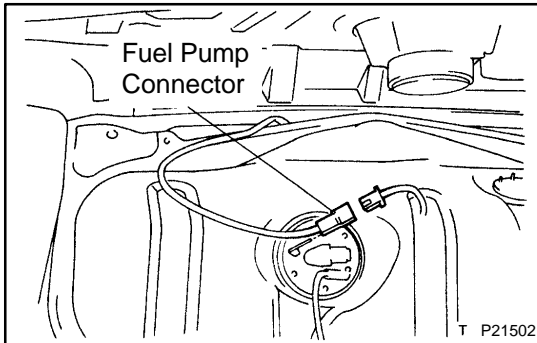

3. DISCONNECT FUEL PUMP CONNECTOR
4. REMOVE SEAT CUSHION AND BACK
5. REMOVE PARTITION COVER

Using a scraper, pry out the partition cover.

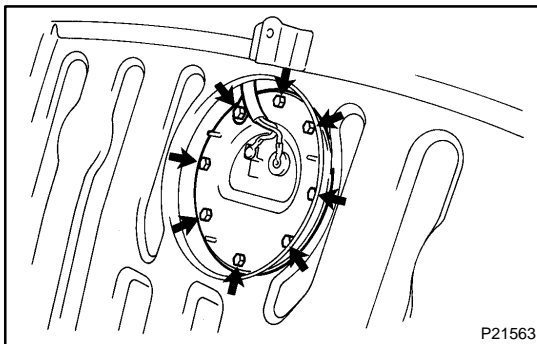

6. REMOVE FUEL PUMP, BRACKET AND SET PLATE ASSEMBLY

- (a) Remove the 8 bolts, and disconnect the fuel pump set plate from the fuel tank.

Torque: 3.0 N·m (30 kgf·cm, 26 in.-lbf)

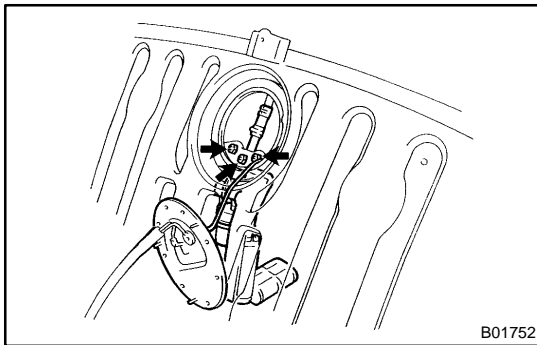

- (b) Remove the 3 nuts, and disconnect the fuel pump bracket from the fuel tank.

Torque: 5.5 N·m (55 kgf·cm, 48 in.-lbf)

- (c) Disconnect the fuel hose from the fuel pump bracket, and remove the fuel pump, bracket, set plate, assembly and gasket.

HINT:

At the time of installation, please refer to the following item.
Use a new gasket.

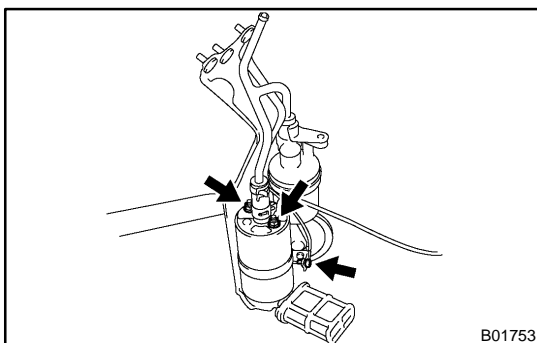

7. REMOVE PUMP SET PLATE FROM FUEL PUMP

- (a) Remove the 2 nuts, 2 spring washers, and disconnect the 2 wires from the fuel pump.

- (b) Remove the fuel pump set plate.

- (c) Remove the screw, and disconnect the wire from the fuel pump earth clamp.

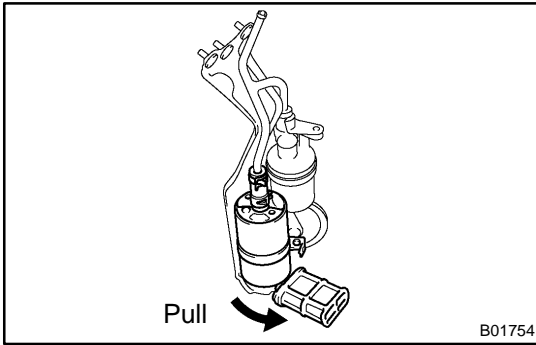
**8. REMOVE FUEL PUMP FROM PUMP BRACKET**

- (a) Pull out the lower side of the fuel pump from the pump bracket.
- (b) Disconnect the fuel hose from the fuel pump, and remove the fuel pump.
- (c) Remove the rubber cushion from the fuel pump.
- (d) Remove the screw and fuel pump earth clamp.

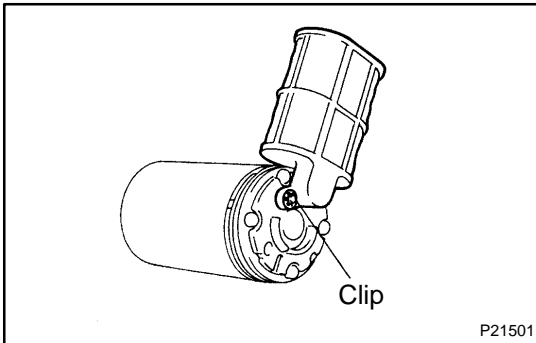
**9. REMOVE FUEL PUMP FILTER FROM FUEL PUMP**

Remove the clip and pull out the filter.

HINT:

At the time of assembly, please refer to the following item.
Use a new clip.

INSTALLATION

Installation is in the reverse order of removal. (See page [SF-10](#))

FUEL PRESSURE REGULATOR

ON-VEHICLE INSPECTION

INSPECT FUEL PRESSURE (See page [SF-5](#))

SF0EW-02

COMPONENTS

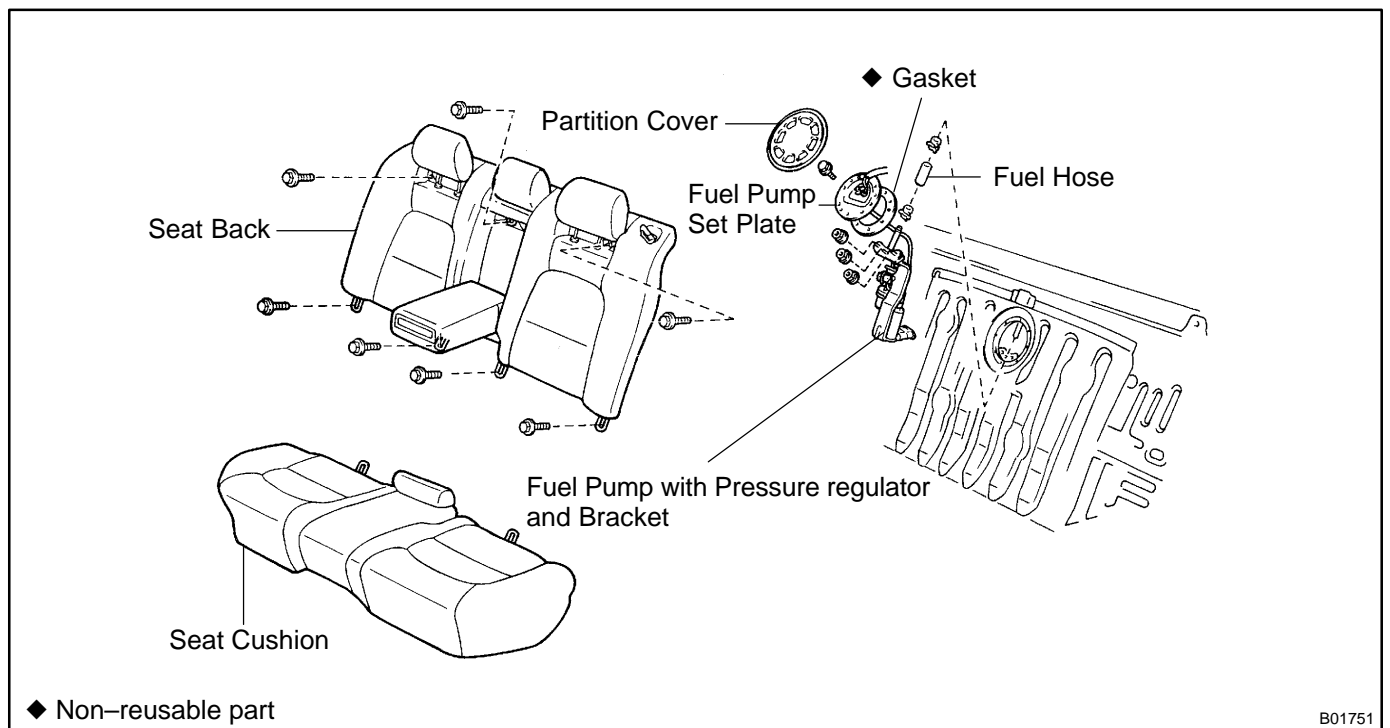
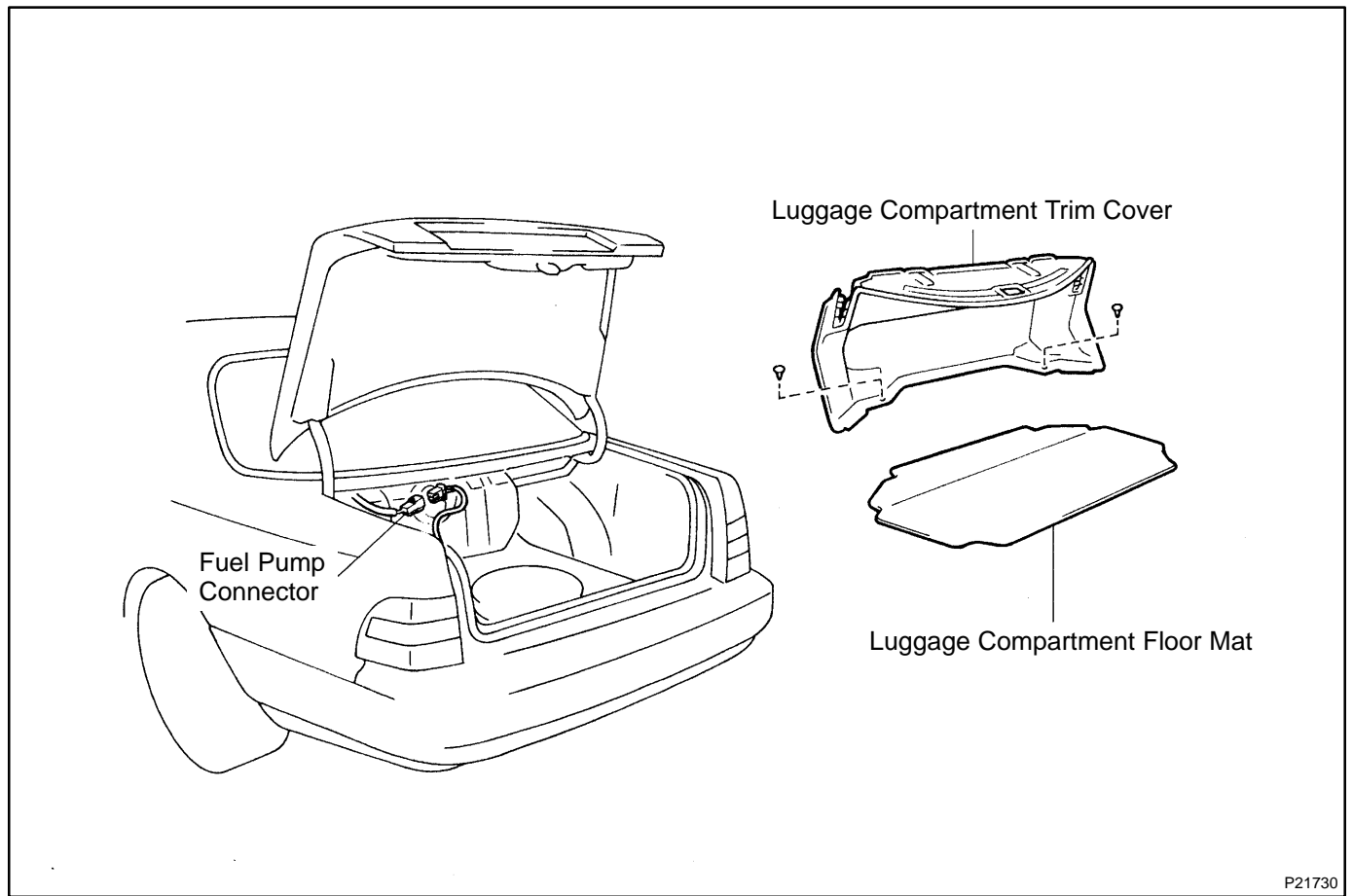

Fuel Pump Set Plate

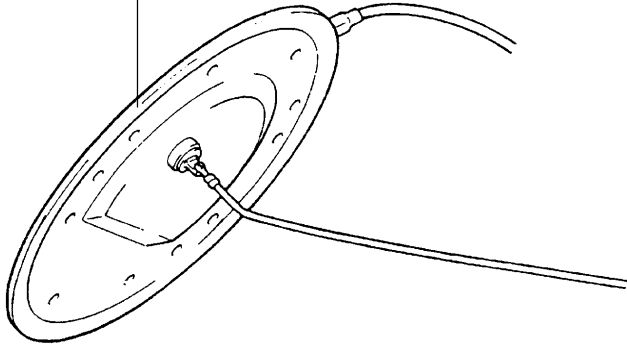

Fuel Pump and Bracket

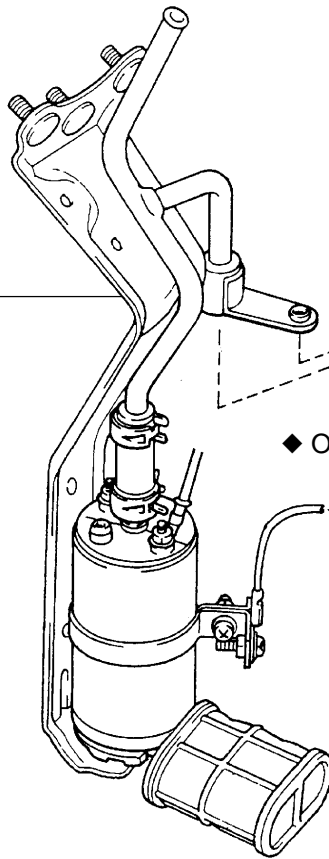

Fuel Pressure regulator

◆ O-Ring

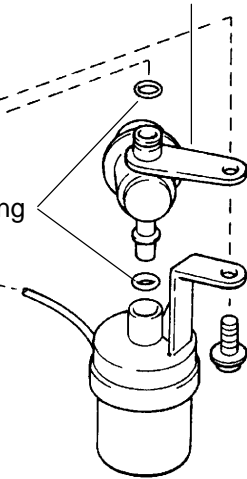

Fuel Filter

◆ Non-reusable part

B01755

REMOVAL

1. REMOVE FUEL PUMP ASSEMBLY FROM FUEL TANK
(See page [SF-10](#))

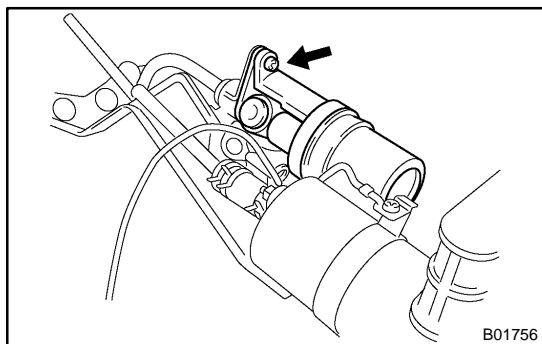

2. REMOVE FUEL PRESSURE REGULATOR
 - (a) Remove the screw, fuel filter and fuel pressure regulator.
 - (b) Remove the O-rings from fuel pressure regulator and fuel filter.

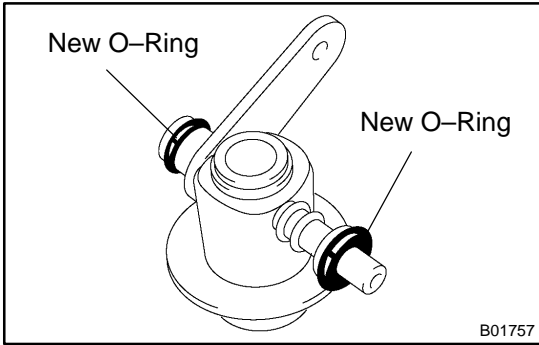

INSTALLATION

1. INSTALL FUEL PRESSURE REGULATOR

- (a) Apply a light coat of gasoline to 2 new O-rings, and install them to the pressure regulator.
- (b) Insert the pressure regulator into the fuel filter by hand completely.
- (c) Insert the pressure regulator and fuel filter assembly into the delivery pipe by hand completely.
- (d) Check that the fuel pressure regulator and fuel filter rotate smoothly

NOTICE:

If it does not rotate smoothly. the O-ring may be pinched, so remove the pressure regulator, fuel filter and do steps (a) and (b) above again.

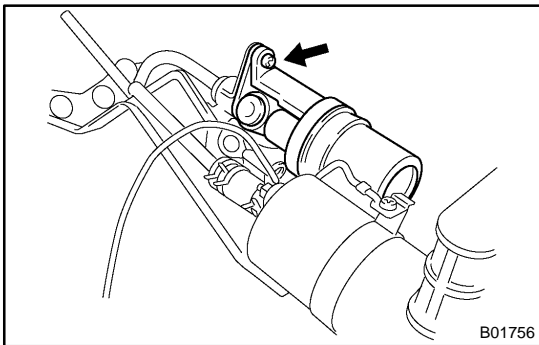
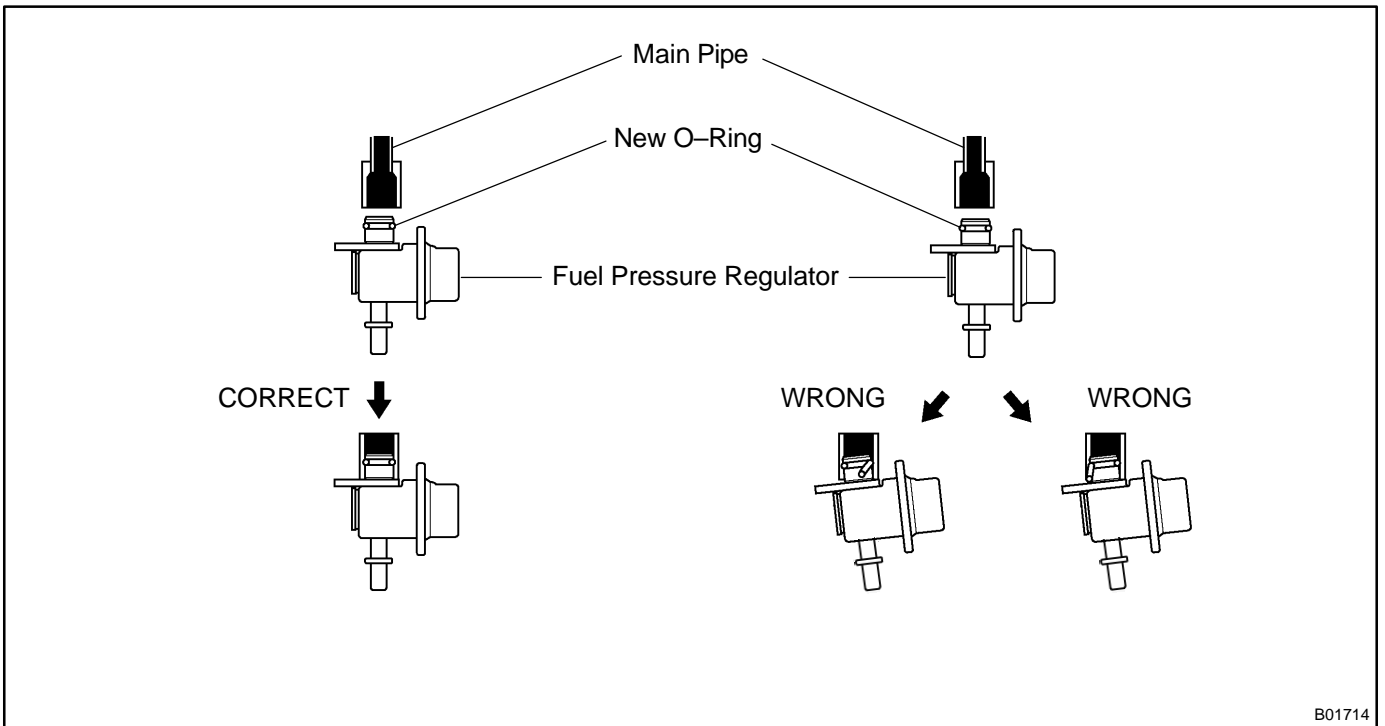

- (e) Install the screw.

Torque: 2.0 N·m (20 kgf·cm, 17 in.-lbf)

2. INSTALL FUEL PUMP ASSEMBLY TO FUEL TANK (See page SF-10)

INJECTOR

ON-VEHICLE INSPECTION

SF0F0-02

1. REMOVE V-BANK COVER
2. REMOVE BATTERY CLAMP COVER AND AIR CLEANER INLET
3. REMOVE INTAKE AIR CONNECTOR
4. INSPECT INJECTOR RESISTANCE
 - (a) Disconnect the 8 injector connectors.

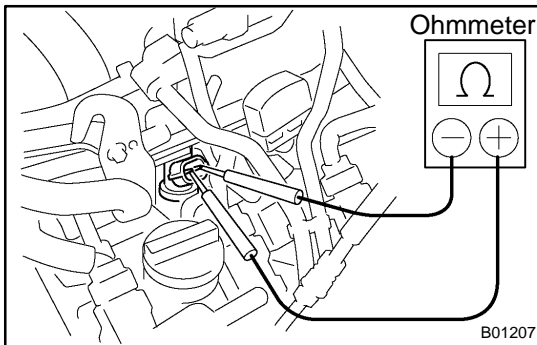

- (b) Using a ohmmeter, measure the resistance between the terminals.

Resistance: 13.4 – 14.2 Ω at 20°C (68°F)

If the resistance is not as specified, replace the injector.

- (c) Reconnect the 8 injector connectors.
5. REINSTALL INTAKE AIR CONNECTOR
6. REINSTALL BATTERY CLAMP COVER AND AIR CLEANER INLET
7. REINSTALL V-BANK COVER

COMPONENTS

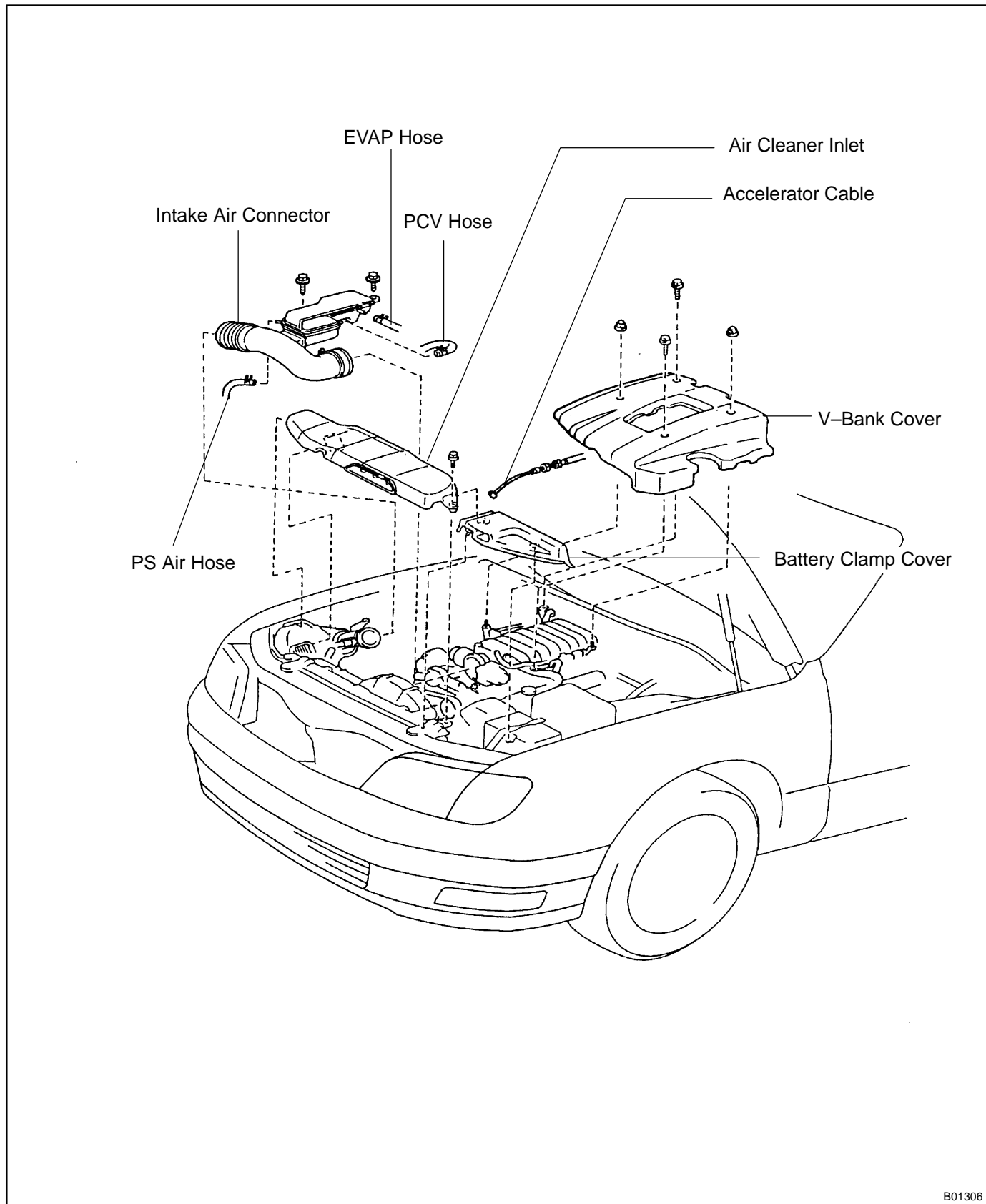

B01306

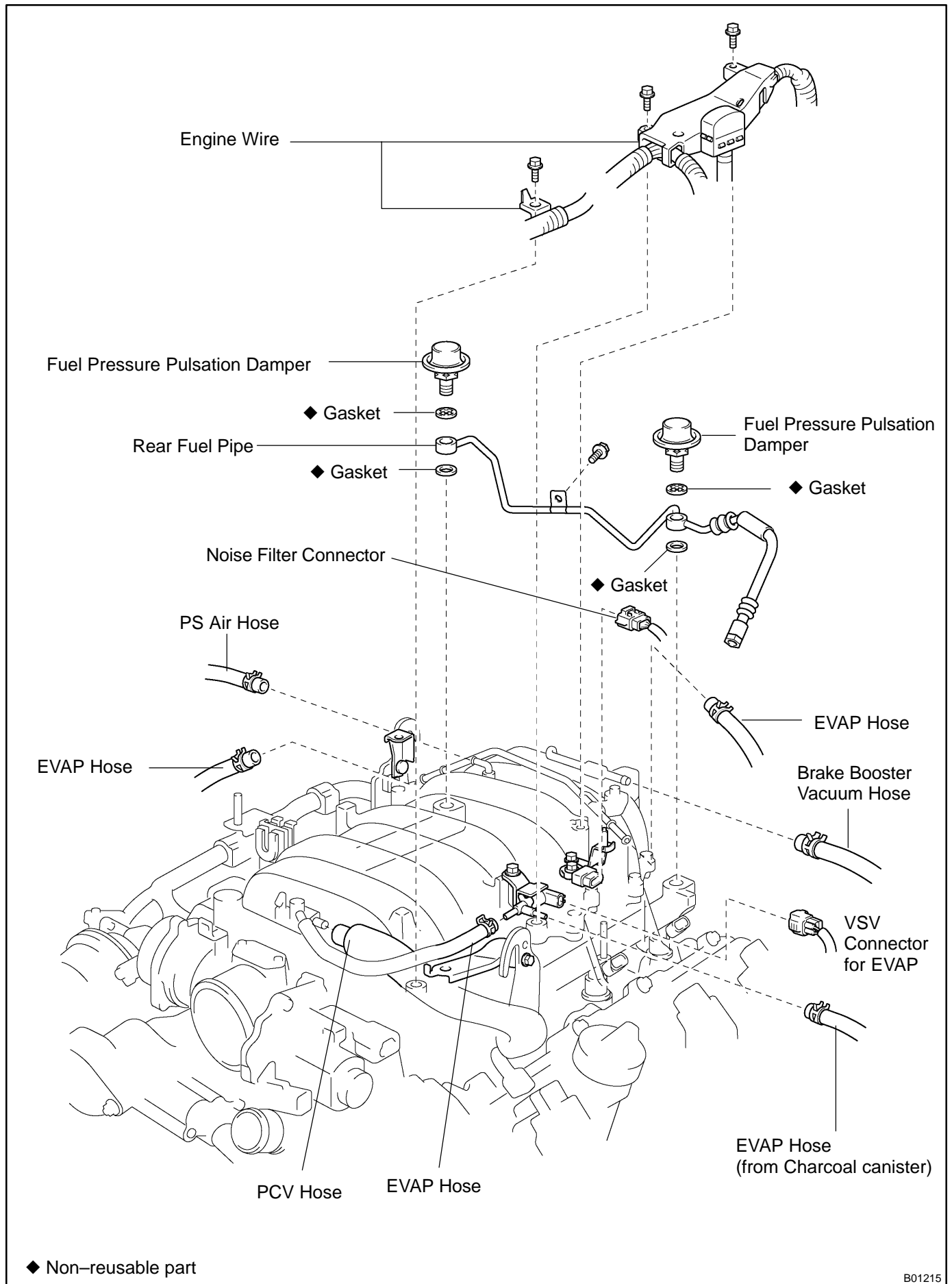

REMOVAL

1. REMOVE V-BANK COVER
2. REMOVE BATTERY CLAMP COVER AND AIR CLEANER INLET
3. REMOVE INTAKE AIR CONNECTOR
4. REMOVE FUEL PRESSURE PULSATION DAMPERS
(See page SF-28)
5. DISCONNECT VVT SENSOR CONNECTORS
6. REMOVE ACCELERATOR CABLE BRACKET

Remove the 2 nuts and accelerator cable bracket.

7. REMOVE 3 V-BANK COVER BRACKETS
 - (a) Disconnect the VSV connector for ACIS from the No.1 V-bank cover bracket.
 - (b) Disconnect the noise filter connector from the noise filter on the No.3 V-bank cover bracket.
 - (c) Remove the 4 bolts and 3 V-bank cover brackets.
8. REMOVE VSV FOR EVAP

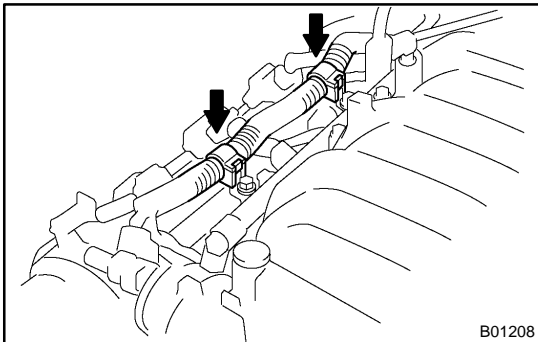

B01208

9. DISCONNECT ENGINE WIRE FROM DELIVERY PIPE
 - (a) Disconnect the 2 wire clamps from the wire clamp bracket on the RH delivery pipe.
 - (b) Disconnect the 8 injector connectors.

10. REMOVE DELIVERY PIPES AND INJECTORS

NOTICE:

- ◆ Be careful not to drop the injectors when removing the delivery pipes.
- ◆ Pay attention to put any hung load on the injector to and from the side direction.

- (a) Remove the 4 nuts holding the delivery pipe to the intake manifold.
- (b) Remove the 2 delivery pipes and 8 injectors assembly and 4 spacers.
- (c) Pull out the 8 injectors from the delivery pipes.
- (d) Remove the 2 O-rings, grommet and insulator from each injector.

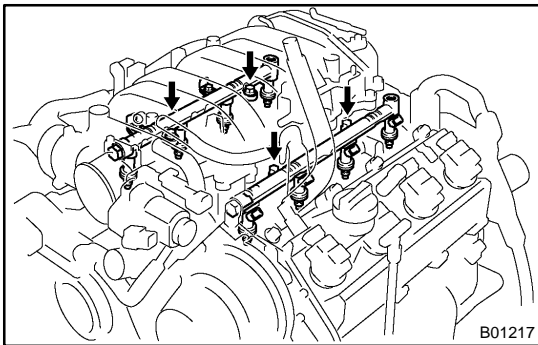

B01217

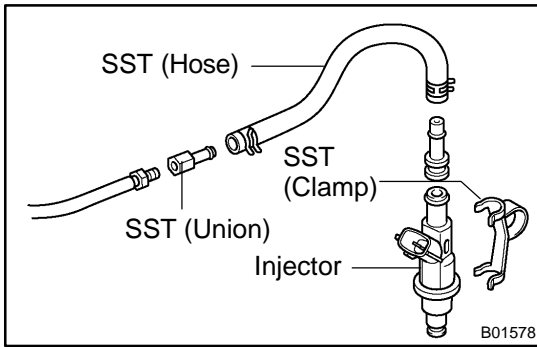

INSPECTION

1. INSPECT INJECTOR INJECTION

CAUTION:

Keep injector clear of sparks during the test.

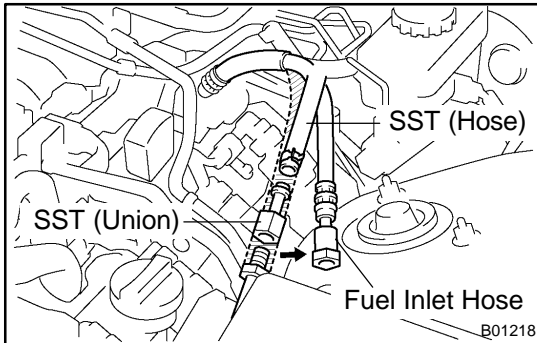

- (a) Disconnect the fuel inlet hose from the fuel tube.
- (b) Connect SST (hose) to the fuel inlet tube with SST (union). Tighten the flare nut on the fuel tube.

SST 09268-41047

Torque: 30 N·m (310 kgf-cm, 22 ft-lbf)

HINT:

Use SST. (See page SF-1)

SST 09631-22020

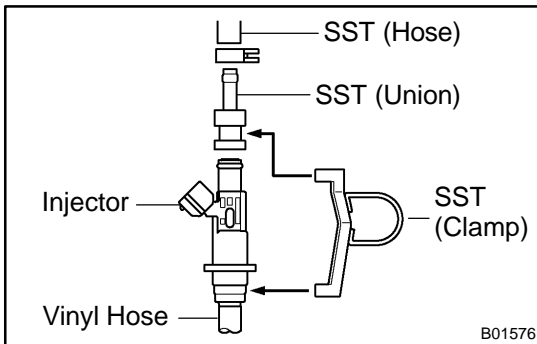

- (c) Install the grommet and O-ring to the injector.
- (d) Connect SST (hose) to the injector with SST (union), and hold the injector and union with SST (clamp).

SST 09268-41047

- (e) Put the injector into the graduated cylinder.

HINT:

Install a suitable vinyl hose onto the injector to prevent gasoline from splashing out.

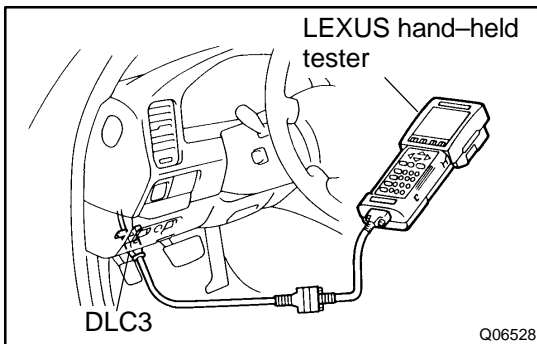

- (f) Connect the LEXUS hand-held tester to the DLC3.
- (g) Turn the ignition switch ON, and push the LEXUS hand-held tester main switch ON.

NOTICE:

DO not start the engine.

- (h) Select the active test mode on the LEXUS hand-held tester.
- (i) Please refer to the LEXUS hand-held tester operator's manual for further details.
- (j) If you have no LEXUS hand-held tester, connect the positive (+) and negative (-) leads from the battery to the fuel pump connector. (See page SF-5)

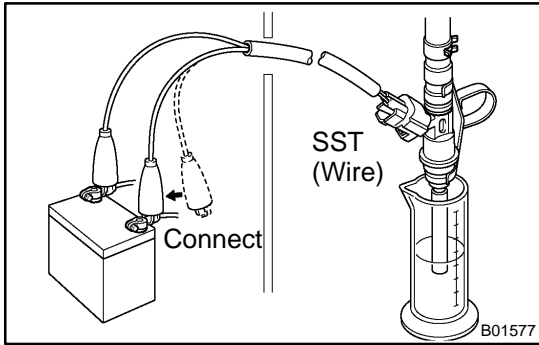

- (k) Connect SST (wire) to the injector and battery for 15 seconds, and measure the injection volume with a graduated cylinder. Test each injector 2 or 3 times.

SST 09842-30070

Injection volume:

60 – 73 cm³ (3.7 – 4.5 cu in.) per 15 sec.

Difference between each injector:

13 cm³ (0.6 cu in.) or less

If the injection volume is not as specified, replace the injector.

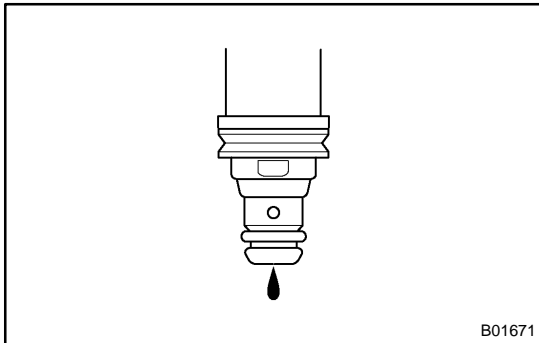

2. INSPECT LEAKAGE

- (a) In the condition above, disconnect the test probes of SST (wire) from the battery and check the fuel leakage from the injector.

SST 09842-30070

Fuel drop: One drop or less per minute

- (b) Turn the ignition switch OFF.
 (c) Disconnect the negative (-) terminal cable from the battery.
 (d) Remove SST.
 SST 09268-41047

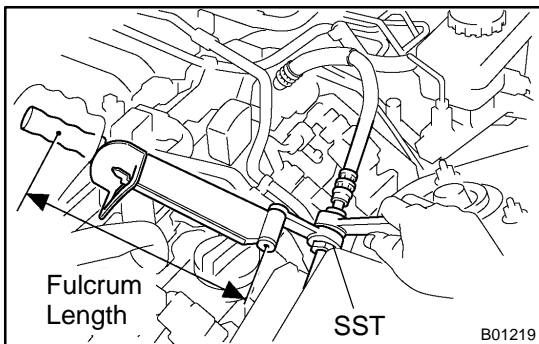

- (e) Reconnect the fuel inlet hose to the fuel tube.

SST 09631-22020

Torque: 30 N·m (310 kgf·cm, 22 ft·lbf)

HINT:

Use a torque wrench with a fulcrum length of 30 cm (11.81 in.).

- (f) Disconnect the LEXUS hand-held tester from the DLC3.

INSTALLATION

1. INSTALL INJECTORS AND DELIVERY PIPES

NOTICE:

- ◆ Be careful not to drop the injectors when installing the delivery pipes.
- ◆ Pay attention to put any hung load on the injector to and from the side direction.

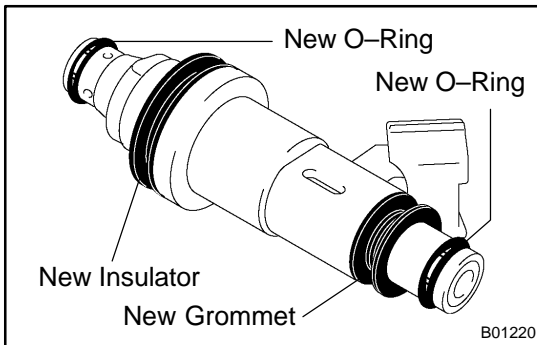

- (a) Install a new grommet and new insulator to each injector.
 (b) Apply a light coat of gasoline to 2 new O-rings and install them to each injector.

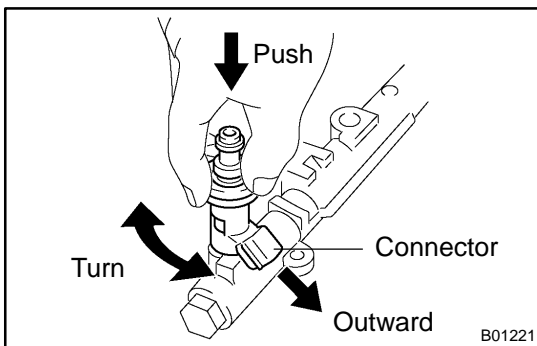

- (c) While turning the injector clockwise and counterclockwise, push it to the delivery pipes. Install the 8 injectors.

HINT:

Install the injector with cover for No. 5, 6, 7 and 8 cylinders.

- (d) Position injector connector outward.

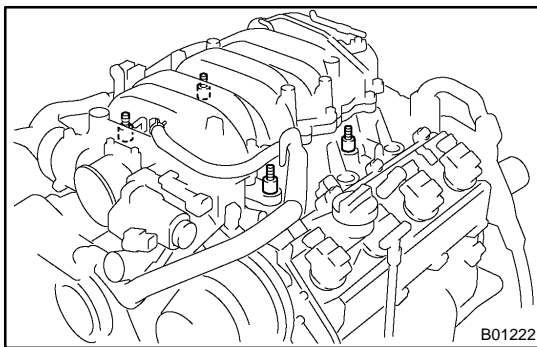

- (e) Place the 4 spacers on the intake manifold.

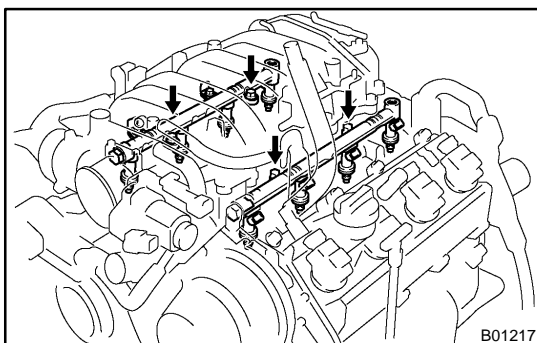

- (f) Place the 8 injectors and 2 delivery pipes assembly in position on the intake manifold.
 (g) Temporarily install the 4 nuts.

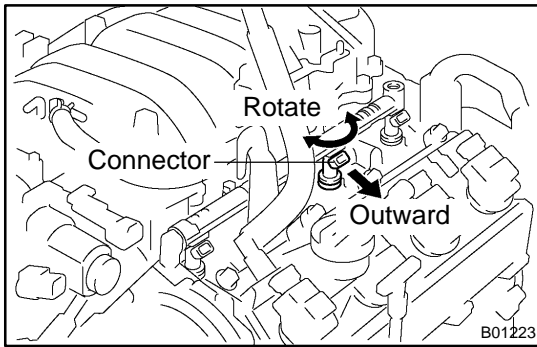

(h) Check that the injectors rotate smoothly.

HINT:

If injectors do not rotate smoothly, the probable cause is incorrect installation of O-rings. Replace the O-rings.

(i) Position injector connector outward.

(j) Tighten the 4 nuts holding the delivery pipes to the intake manifold.

Torque: 18 N·m (185 kgf·cm, 13 ft·lbf)

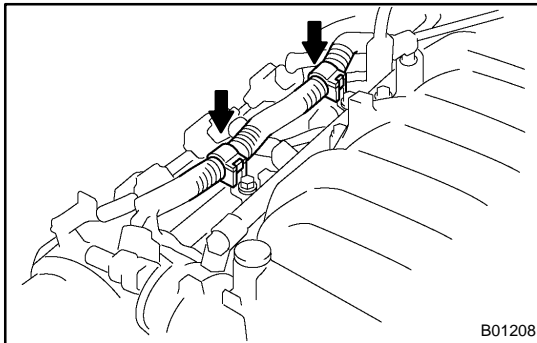

2. CONNECT ENGINE WIRE TO DELIVERY PIPE

(a) Connect the 8 injector connectors.

(b) Connect the 2 wire clamps to the wire clamp bracket on the RH delivery pipe.

3. INSTALL VSV FOR EVAP

Torque: 18 N·m (185 kgf·cm, 13 ft·lbf)

4. INSTALL 3 V-BANK COVER BRACKETS

(a) Install the 3 V-bank cover brackets with the 4 bolts.

Torque: 7.5 N·m (80 kgf·cm, 66 in.-lbf)

(b) Connect the VSV connector for ACIS to the No.1 V-bank cover bracket.

(c) Connect the noise filter connector to the noise filter on the No.3 V-bank cover bracket.

5. INSTALL ACCELERATOR CABLE BRACKET

Install the accelerator cable bracket with the 2 nuts.

Torque: 18 N·m (185 kgf·cm, 13 ft·lbf)

6. CONNECT VVT SENSOR CONNECTORS

7. INSTALL FUEL PRESSURE PULSATION DAMPER

(See page [SF-29](#))

8. INSTALL INTAKE AIR CONNECTOR

9. INSTALL AIR CLEANER INLET AND BATTERY CLAMP COVER

10. INSTALL V-BANK COVER

FUEL PRESSURE PULSATION DAMPER COMPONENTS

SFOF5-02

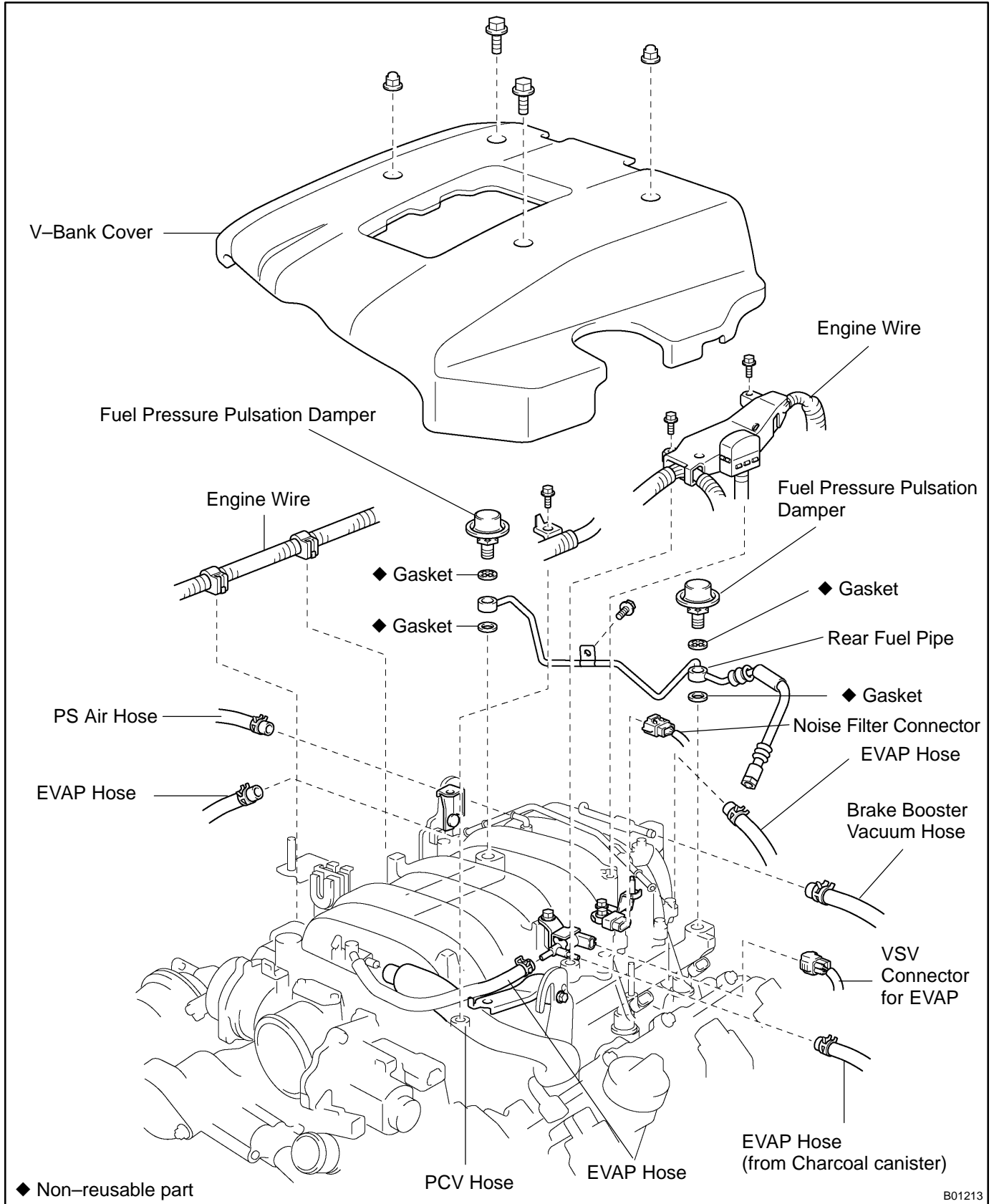

REMOVAL

1. REMOVE V-BANK COVER
2. DISCONNECT ACCELERATOR CABLE

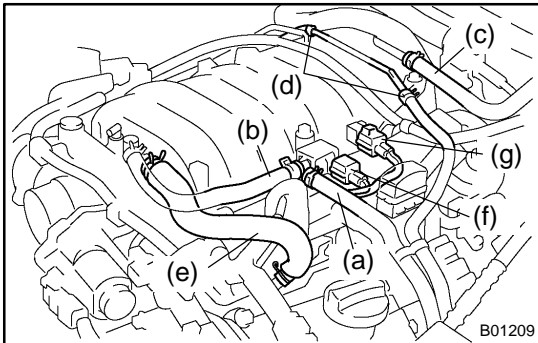

3. DISCONNECT ENGINE WIRE FROM INTAKE MANIFOLD

- (a) Disconnect the EVAP hose (from the charcoal canister).
 - (b) Disconnect the EVAP hose.
 - (c) Disconnect the brake booster vacuum hose.
 - (d) Disconnect the 2 EVAP hoses.
 - (e) Disconnect the PCV hose.
 - (f) Disconnect the VSV connector for EVAP.
 - (g) Disconnect the noise filter connector.
- (h) Remove the 3 bolts, and disconnect the engine wire protector and wire clamp bracket from the intake manifold.

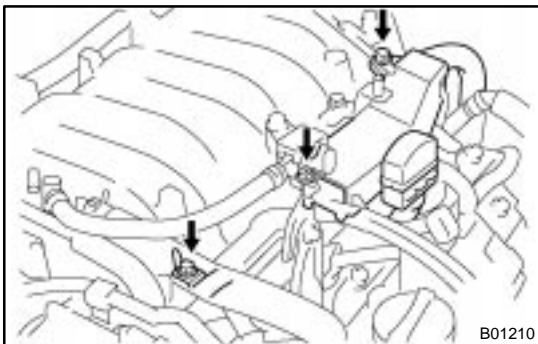

4. REMOVE FUEL PRESSURE PULSATION DAMPERS

- (a) Remove pulsation damper and upper gasket. Remove the 2 pulsation dampers and 2 upper gaskets.
- (b) Disconnect the rear fuel pipe from the RH and LH delivery pipes, and remove the 2 lower gaskets.

CAUTION:

- ◆ Put a shop towel under the delivery pipe.
- ◆ Slowly loosen the pulsation damper.

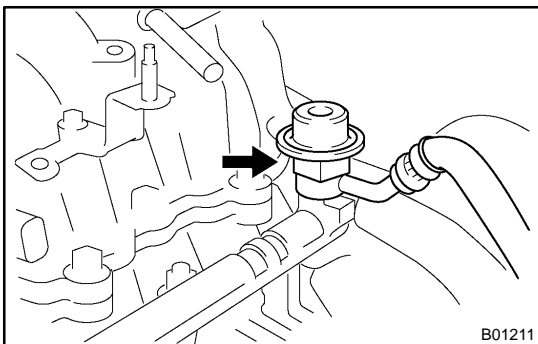

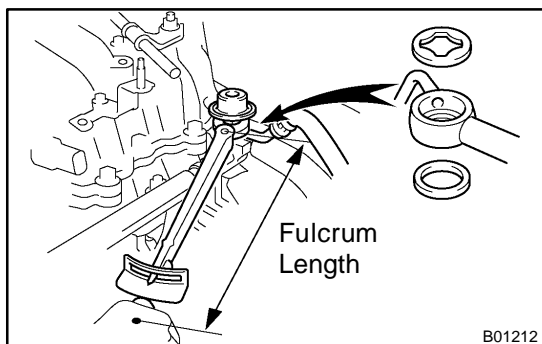

INSTALLATION

1. INSTALL FUEL PRESSURE PULSATION DAMPERS

Using SST, install 2 new gaskets, the rear fuel pipe and pulsation damper. Install the 2 pulsation dampers.

SST 09612-24014 (09617-24011)

Torque:

39 N·m (400 kgf·cm, 29 ft·lbf)

33 N·m (340 kgf·cm, 24 ft·lbf) for SST

HINT:

Use a torque wrench with a fulcrum length of 30 cm (11.81 in.).

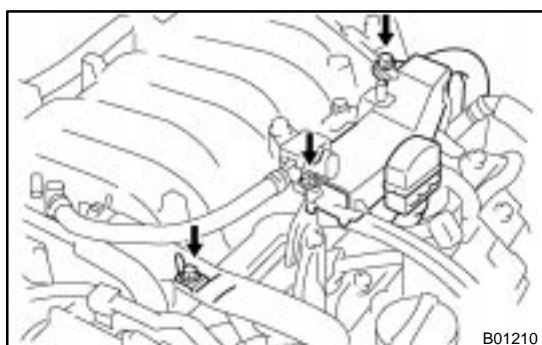

2. CONNECT ENGINE WIRE

- (a) Connect the engine wire with cover and wire clamp bracket with 3 bolts to intake manifold.

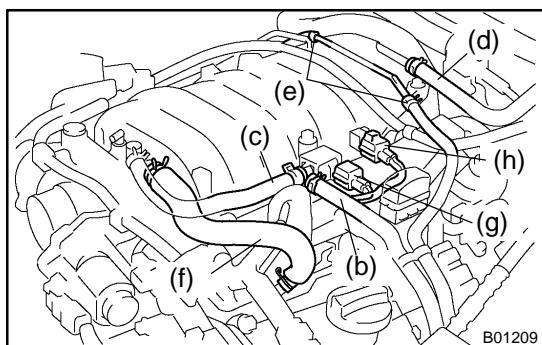

- (b) Connect the EVAP hose (from the charcoal canister).
 (c) Connect the EVAP hose.
 (d) Connect the brake booster vacuum hose.
 (e) Connect the 2 EVAP hoses.
 (f) Connect the PCV hose.
 (g) Connect the VSV connector for EVAP.
 (h) Connect the noise filter connector.

3. **CHECK FOR FUEL LEAKS (See page SF-1)**
 4. **CONNECT ACCELERATOR CABLE**
 5. **INSTALL V-BANK COVER**

FUEL TANK AND LINE COMPONENTS

SF0F8-03

CAUTION:

- ◆ Always use new gaskets when replacing the fuel tank or components part.
- ◆ Apply the proper torque to all parts tightened.

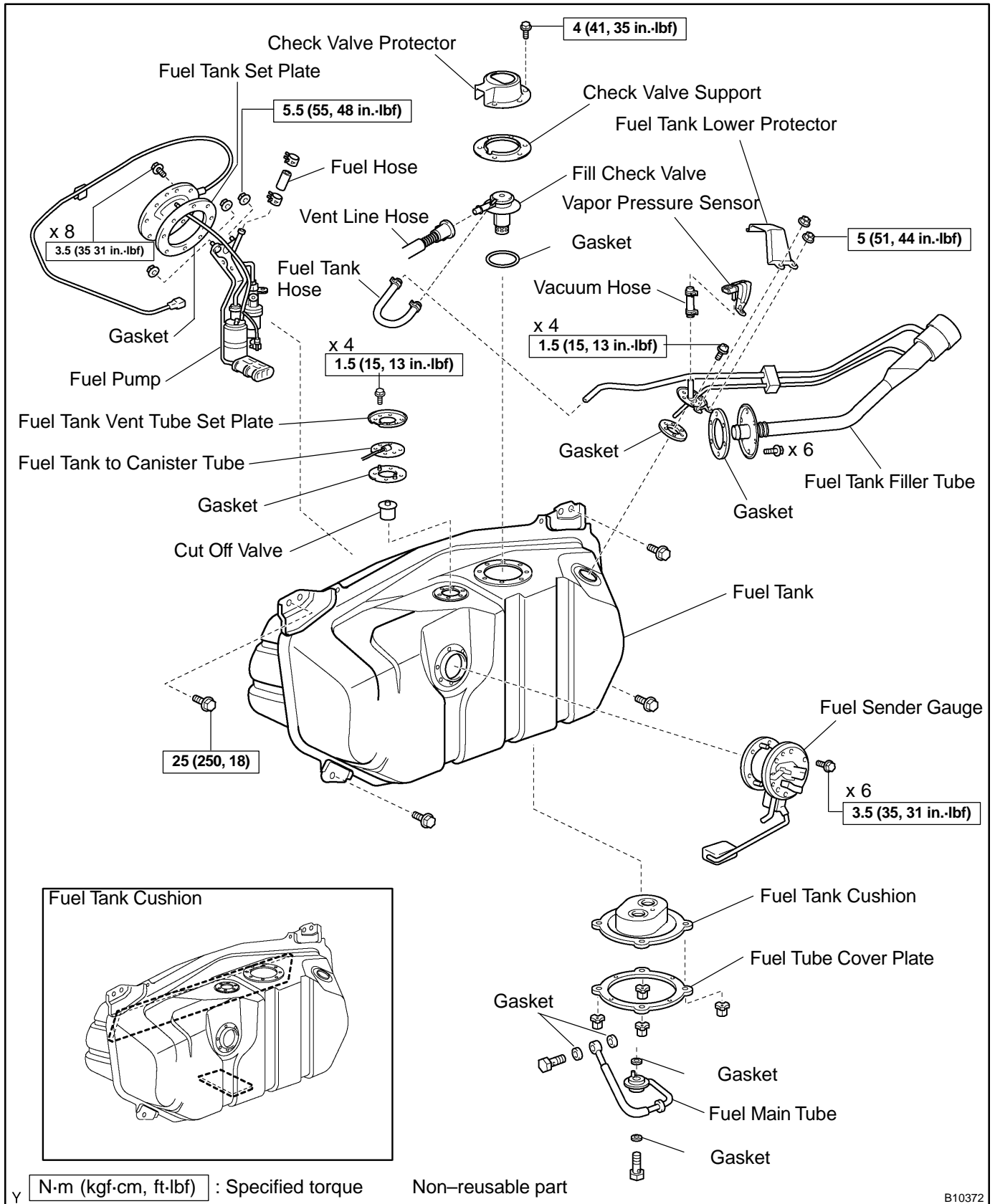

B10372

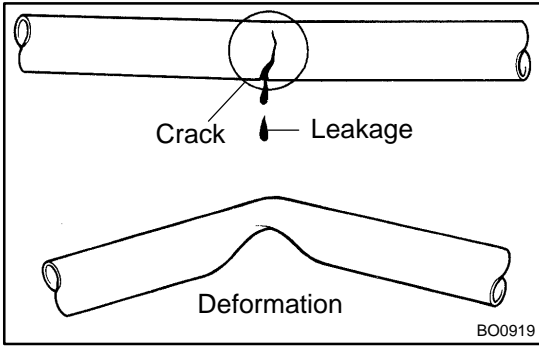

INSPECTION

INSPECT FUEL TANK AND LINE

- (a) Inspect the fuel lines and connections for cracks, leakage or deformation.
- (b) Inspect the fuel tank vapor vent system hoses and connections for looseness, kinks or damage.
- (c) Inspect the fuel tank for deformation, cracks, fuel leakage or tank band looseness.
- (d) Check the filter neck for damage or fuel leakage.
- (e) Hose and tube connections are as shown in the illustration.

If the problem is found, repair or replace the parts as necessary.

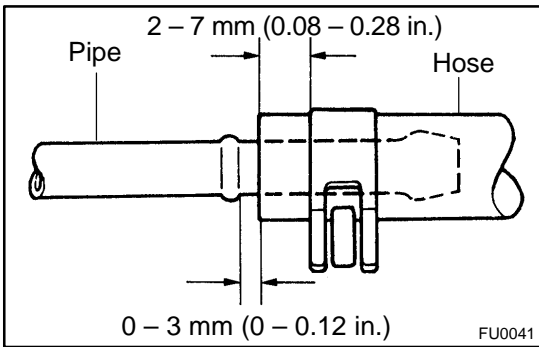
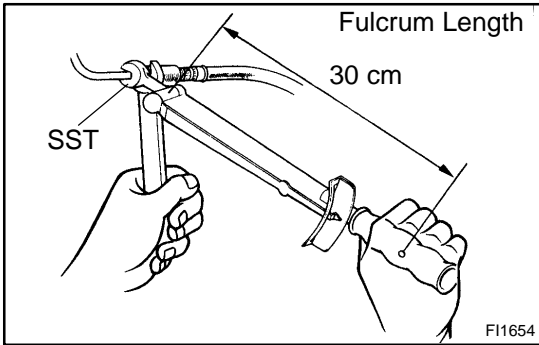

MASS AIR FLOW (MAF) METER COMPONENTS

SFOFA-02

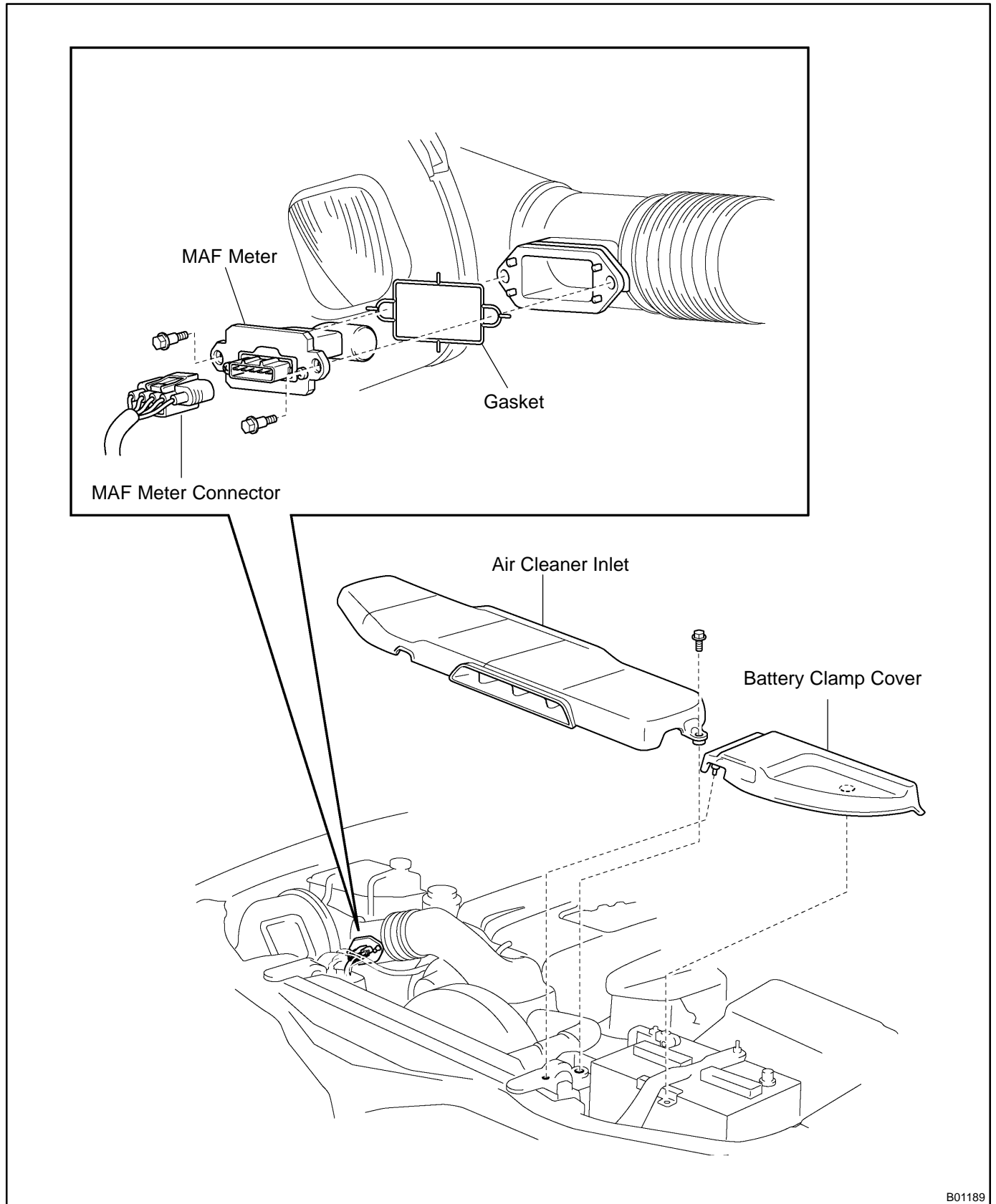

B01189

REMOVAL

1. REMOVE BATTERY CLAMP COVER AND AIR CLEANER INLET

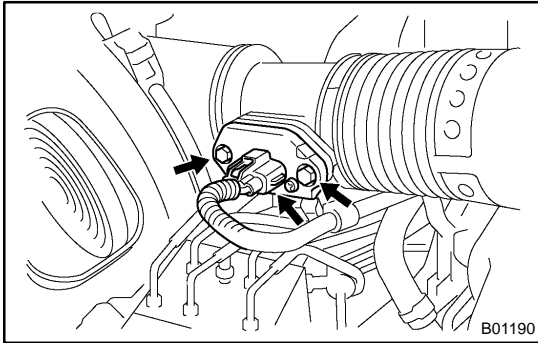

2. REMOVE MAF METER

- (a) Disconnect the MAF meter connector.
- (b) Remove the 2 bolts, MAF meter and gasket.

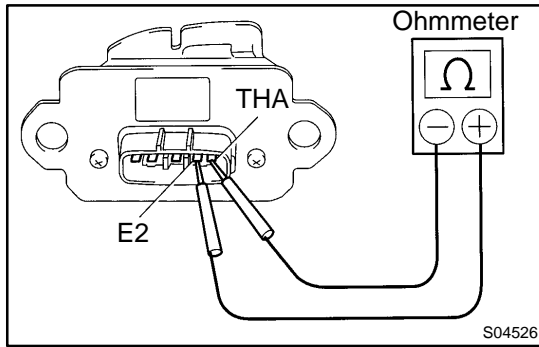

INSPECTION

1. INSPECT MAF METER RESISTANCE

Using an ohmmeter, measure the resistance between terminals THA and E2.

Terminals	Resistance	Temperature
THA - E2	13.6 - 18.4 k Ω	-20°C (-4°F)
THA - E2	2.21 - 2.69 k Ω	20°C (68°F)
THA - E2	0.493 - 0.667 k Ω	60°C (140°F)

If the resistance is not as specified, replace the MAF meter.

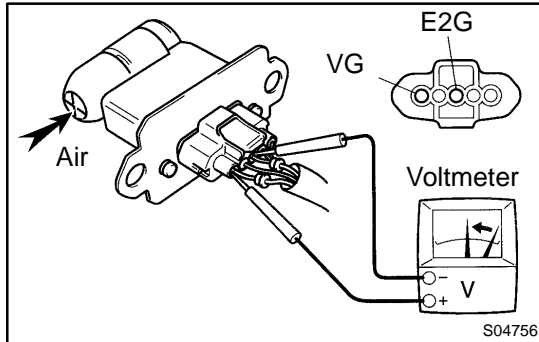

2. INSPECT MAF METER OPERATION

- Connect the MAF meter connector.
- Turn the ignition switch ON.
- Using a voltmeter, connect the positive (+) tester probe to terminal VG, and negative (-) tester probe to terminal E2G.
- Blow air into the MAF meter, and check that the voltage fluctuates.

If operation is not as specified, replace the MAF meter.

- Turn the ignition switch LOCK.
- Disconnect the MAF meter connector.

INSTALLATION

Installation is in the reverse order of removal. (See page [SF-33](#))

THROTTLE BODY ON-VEHICLE INSPECTION

SFOFE-02

1. REMOVE V-BANK COVER

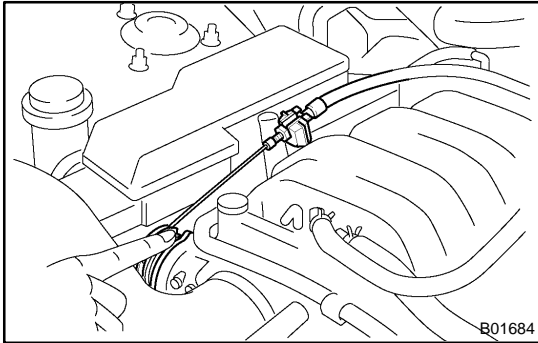

2. INSPECT SYSTEM OPERATION

- (a) Check that the throttle linkage moves smoothly.

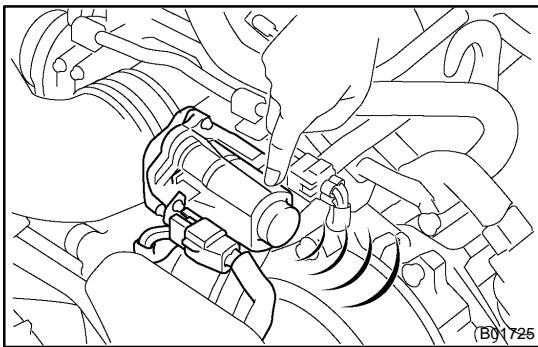

- (b) Inspect the throttle control motor for operating sound.
- (1) Turn the ignition switch ON.
 - (2) When turning the accelerator pedal position sensor lever, check the running sound of the motor. Also, check that there is no friction sound.

If operation is not as specified, check the throttle control motor (See step 4), wiring and ECM.

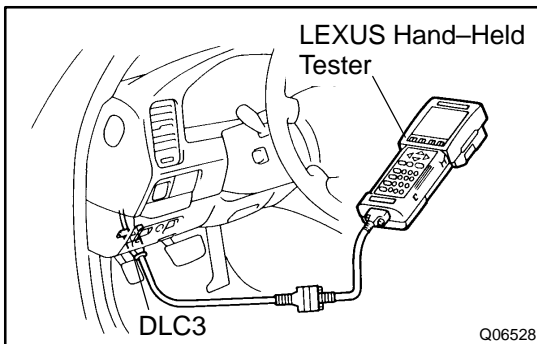

- (c) Inspect the accelerator pedal position sensor.
- (1) Connect the LEXUS hand-held tester to the DLC3.
 - (2) Check that the MIL does not light up.
 - (3) When turning the accelerator pedal position sensor lever to the full-open position, check that the throttle valve opening percentage (THROTTLE POS) of the CURRENT DATA shows the standard value.

**Standard throttle valve opening percentage:
60 % or more**

If operation is not as specified, check that the accelerator pedal position sensor (See step 5), wiring and ECM.

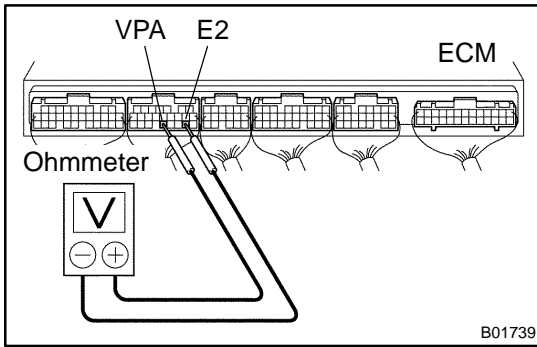

If you have no LEXUS hand-held tester, measure voltage between terminals VPA and E2 of the ECM connector.

- (d) Inspect the air assist system.
- (1) Start the engine and check that the MIL does not light up.
 - (2) Allow the engine to warm up to normal operating temperature.
 - (3) Turn the A/C conditioning ON to OFF, and check the idle speed.

Idle speed (Transmission in neutral): 750 ± 50 rpm

NOTICE:

Perform inspection under condition without electrical load.

- (e) After checking the above (b) to (d), perform the driving test and check that there is no sense of incongruity.

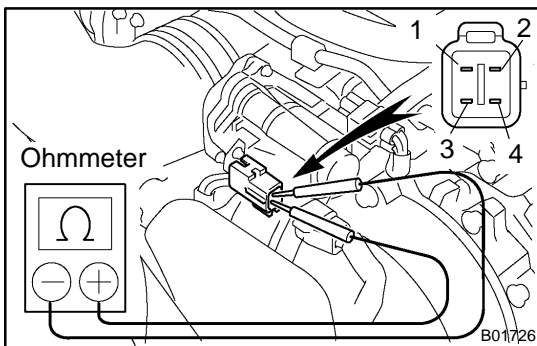

3. INSPECT THROTTLE CONTROL MOTOR w/ CLUTCH

- (a) Disconnect the throttle control motor w/ clutch connector.
- (b) Using an ohmmeter, measure the motor resistance between terminal 1 (M+) and 2 (M-).

Motor resistance: 0.3 – 100 Ω at 20°C (68°F)

If the resistance is not as specified, replace the throttle control motor w/ clutch. (See page [SF-43](#))

- (c) Using an ohmmeter, measure the clutch resistance between terminal 3 (CL-) and 4 (CL+).

Clutch resistance: 4.2 – 5.2 Ω at 20°C (68°F)

If the resistance is not as specified, replace the throttle control motor w/ clutch. (See page [SF-43](#))

- (d) Reconnect the throttle control motor connector.

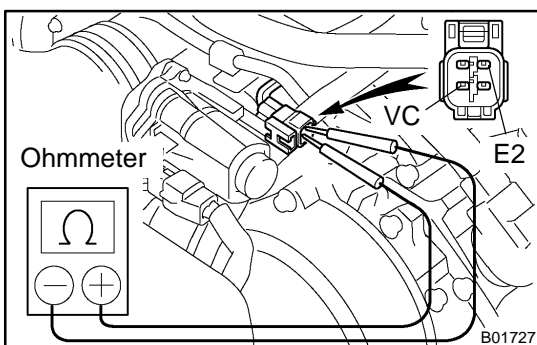

4. INSPECT THROTTLE POSITION SENSOR

- (a) Disconnect the throttle position sensor connector.
- (b) Using an ohmmeter, measure the resistance between terminals VC and E2.

Resistance: 1.25 – 2.35 kΩ at 20°C (68°F)

If the resistance is not as specified, replace the throttle position sensor. (See page [SF-43](#))

- (c) Reconnect the throttle position sensor connector.

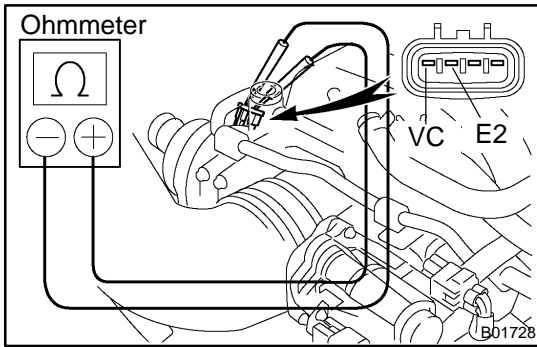

5. INSPECT ACCELERATOR PEDAL POSITION SENSOR

- (a) Disconnect the accelerator position sensor connector.
- (b) Using an ohmmeter, measure the resistance between terminals VC and E2.

Resistance: 1.64 – 3.28 kΩ at 20°C (68°F)

If the resistance is not as specified, replace the accelerator pedal position sensor. (See page [SF-43](#))

- (c) Reconnect the accelerator pedal position sensor connector.

6. REINSTALL V-BANK COVER

COMPONENTS

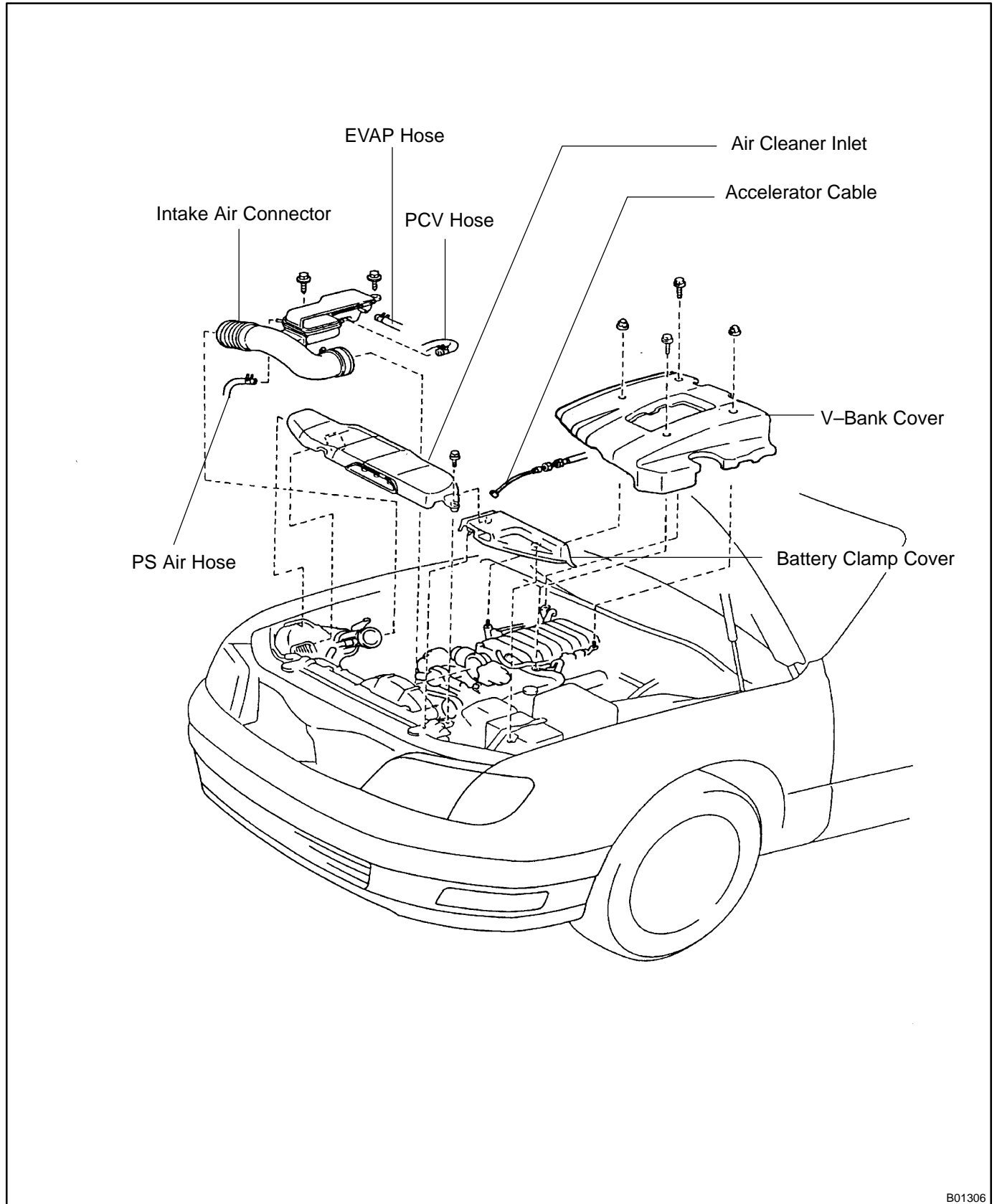

B01306

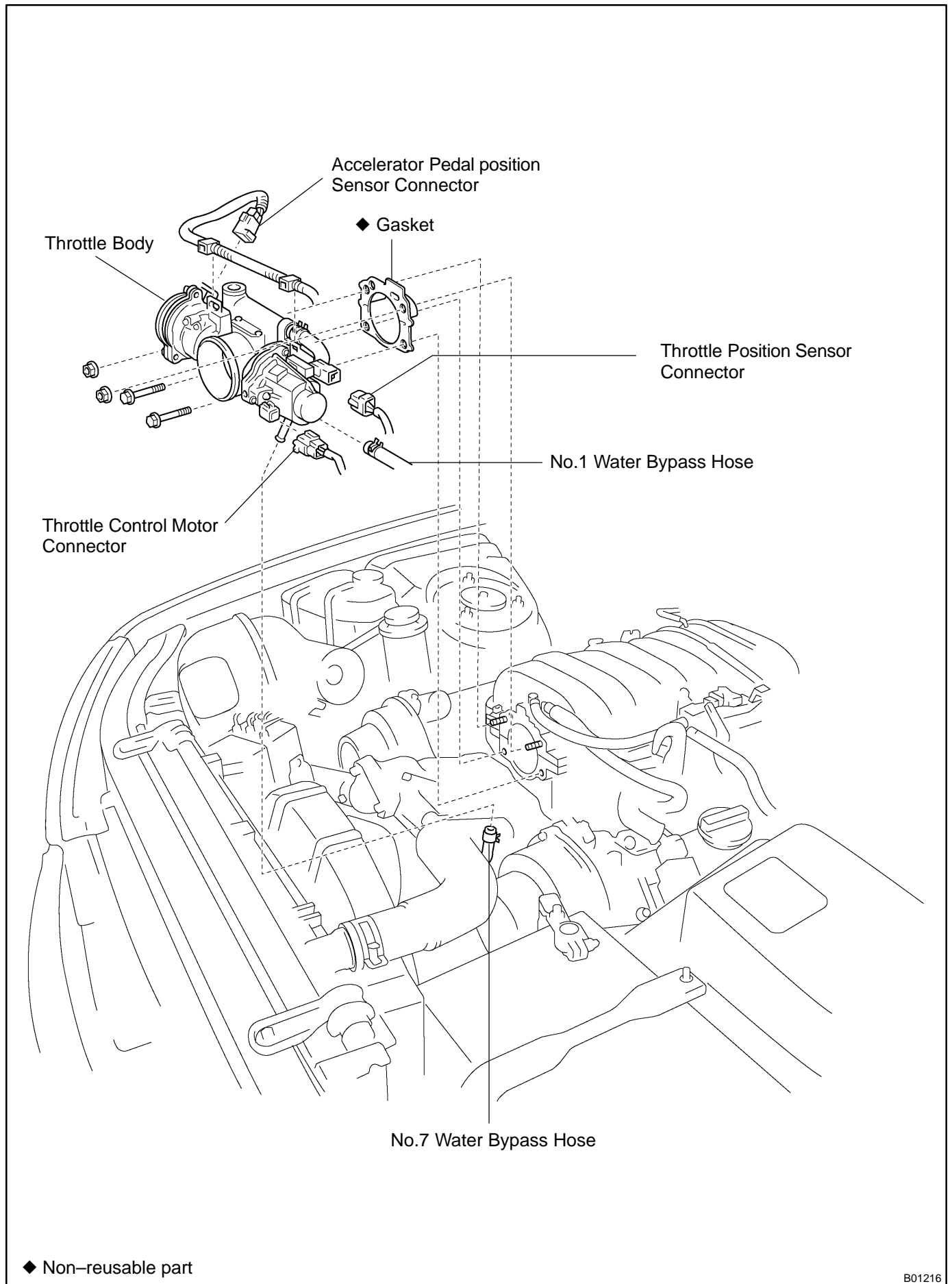

B01216

SFI - THROTTLE BODY

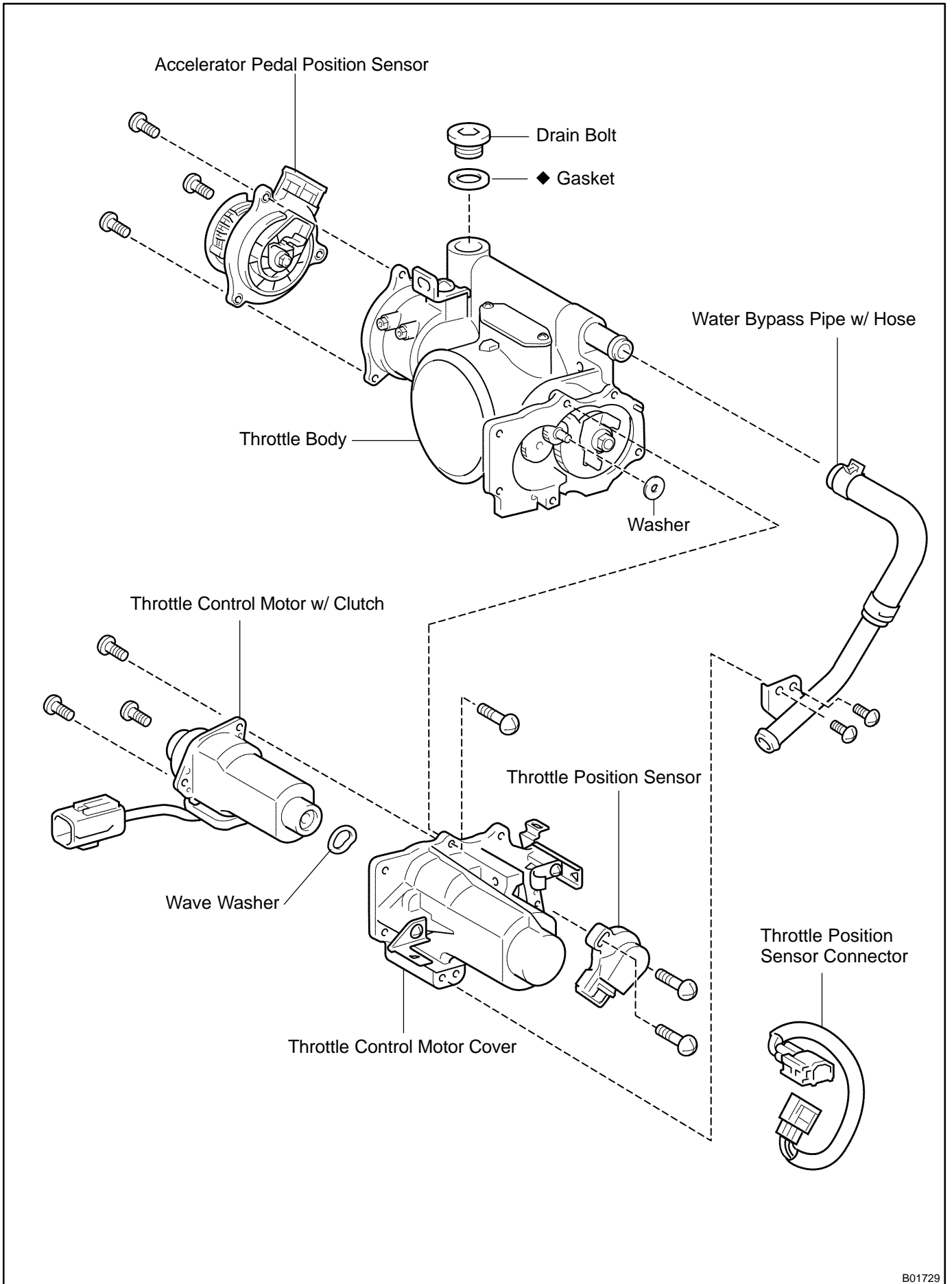

B01729

REMOVAL

1. REMOVE V-BANK COVER
2. DRAIN ENGINE COOLANT
3. REMOVE BATTERY CLAMP COVER AND AIR CLEANER INLET
4. REMOVE INTAKE AIR CONNECTOR
5. DISCONNECT ACCELERATOR CABLE FROM THROTTLE BODY

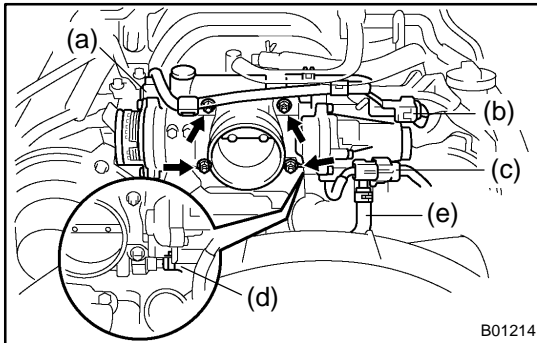

6. REMOVE THROTTLE BODY

- (a) Disconnect the accelerator pedal position sensor connector.
- (b) Disconnect the throttle position sensor connector.
- (c) Disconnect the throttle control motor connector.
- (d) Disconnect the No.1 water bypass hose.
- (e) Disconnect the No.7 water bypass hose.
- (f) Disconnect the 2 wire clamps from the throttle body.
- (g) Remove the 2 bolts, 2 nuts, throttle body and gasket.

Torque: 18 N·m (185 kgf-cm, 13 ft-lbf)

HINT:

At the time of installation, please refer to the following item.
Use a new gasket.

REPLACEMENT

NOTICE:

- ◆ To prevent deterioration, do not shock the throttle position sensor and accelerator pedal position sensor.
- ◆ Mixing of the foreign objects may cause the gear locking, so thoroughly check that there is no stuck of any foreign objects and clean up if any.

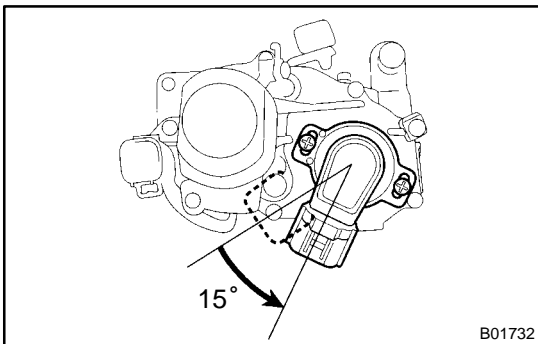
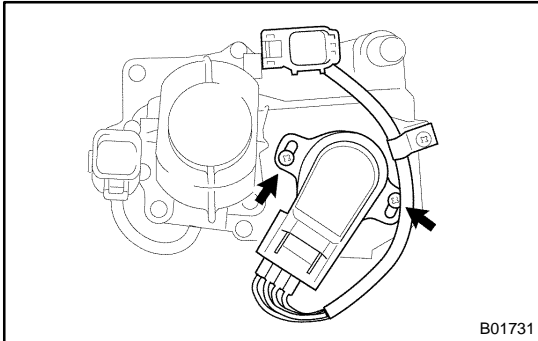

1. REPLACE THROTTLE POSITION SENSOR

- (a) Remove the 2 screws and water bypass pipe w/ hose.
- (b) Disconnect the connector from the throttle position sensor and bracket.
- (c) Widen the clamp with your hand and remove the wire harness from the clamp.
- (d) Remove the 2 set screws and throttle position sensor.
- (e) Reinstall the throttle position sensor.
 - (1) Check that the throttle valve is under the condition of the opener opening angle (about 4°).
 - (2) Install the sensor to the place where is at 15° rotated to the right from the specified installation position.
 - (3) Gradually turn sensor counterclockwise until it touches the throttle valve shaft and temporarily torque the 2 set screws.
- (f) Install the wire harness to the clamp, and connect the connector to the throttle position sensor and bracket.
- (g) Adjust the throttle position sensor.
 - (1) Connect the throttle position sensor connector.

NOTICE:

Do not connect the accelerator pedal position sensor connector.

- (2) Connect the LEXUS hand-held tester or OBDII scan tool to the DLC3.
- (3) Turn the ignition switch ON.

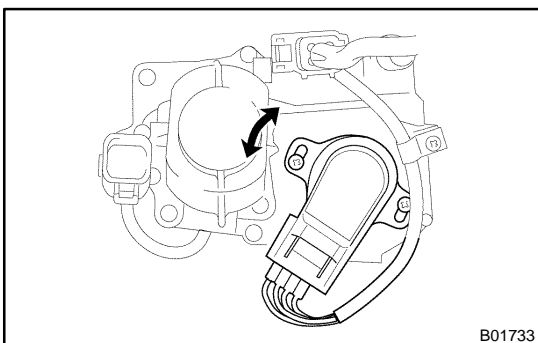

- (4) While reading the valve of the throttle valve opening percentage (THROTTLE POS) of the CURRENT DATA, turn the throttle position sensor slowly to left and right and set the sensor at the center value of the standard value, and then torque the screws.

Standard throttle valve opening percentage:

14.4 – 16 %

Torque: 2 N·m (20 kgf·cm, 17in.-lbf)

NOTICE:

After turning the ignition switch ON, do not depress the accelerator pedal.

- (5) Recheck throttle valve opening percentage.

If the throttle valve opening percentage is not as specified, repeat step (4).

- (6) Perform fully closed throttle valve by hand and check that the valve of the throttle valve opening percentage (THROTTLE POS) of the CURRENT DATA stays with the standard value.

Standard throttle valve opening percentage:

10 – 14 %

If the throttle valve opening percentage is not as specified, repeat steps (4) to (6).

- (7) Paint the sensor set screw.
 (8) Turn the ignition switch OFF.
 (9) Disconnect the LEXUS hand-held tester or OBDII scan tool from the DLC3.
 (10) Disconnect the throttle position sensor connector.
 (h) Reinstall the water bypass pipe w/ hose with the 2 screws.

Torque: 5.4 N·m (55 kgf·cm, 47in.-lbf)

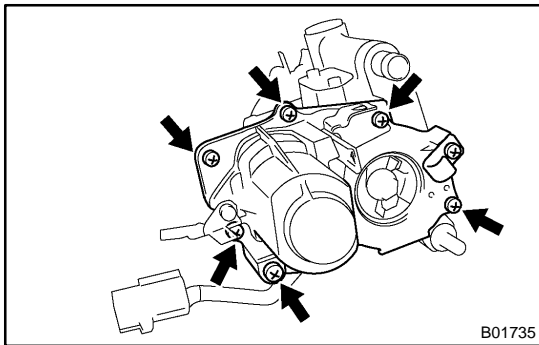
**2. REPLACE THROTTLE CONTROL MOTOR w/ CLUTCH**

- (a) Remove the water bypass pipe w/ hose.
 (b) Remove the throttle position sensor.
 (c) Remove the throttle control motor w/ clutch.
 (1) Disconnect the connector from the bracket.
 (2) Remove the 6 screws, cover and motor assembly and washer.

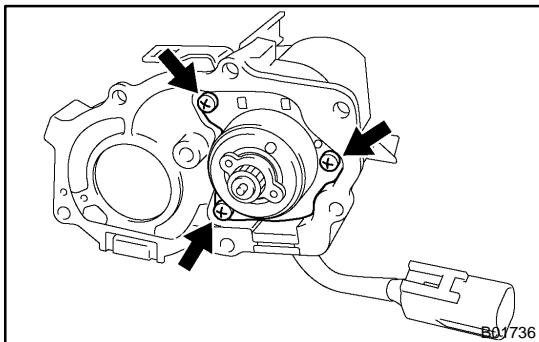

- (3) Remove the 3 screws, throttle control motor w/ clutch and wave washer from the cover.

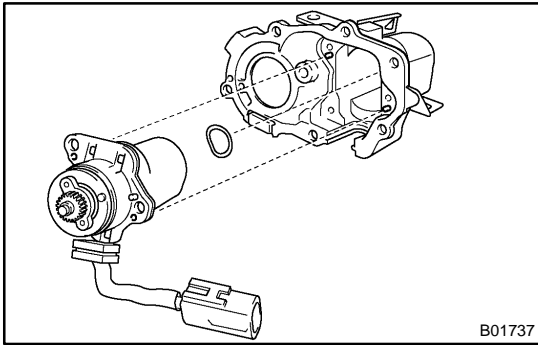

- (d) Reinstall the throttle control motor w/ clutch.
- (1) Place the wave washer to the cover.
 - (2) Match the holes of the positioning pin of the cover and the motor, and then install the throttle control motor w/ clutch with the 3 set screws.

Torque: 3.4 N·m (35 kgf·cm, 30 in.-lbf)

- (3) Apply the grease thinly on the whole surface of the gear teeth.

NOTICE:

Do not apply the grease other than specified because grease has been already applied to the component to be replaced.

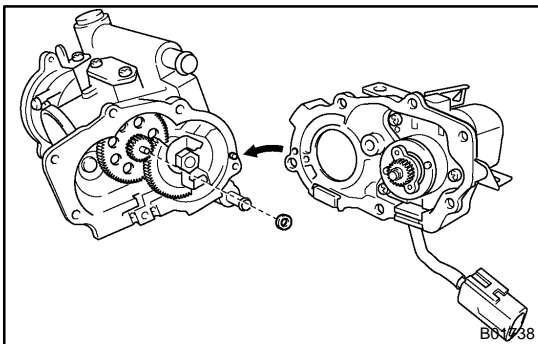

- (4) Place the washer as shown in the illustration.
- (5) Match the holes of the positioning pin of the throttle body and the motor cover, and then install the throttle control motor and cover assembly with the 6 set screws.

Torque: 3.4 N·m (35 kgf·cm, 30 in.-lbf)

- (6) Connect the connector to the bracket.

- (e) Reinstall and adjust the throttle position sensor. (See step 1)

- (f) Reinstall the water bypass pipe w/ hose.

3. REPLACE ACCELERATOR PEDAL POSITION SENSOR

- (a) Remove the 3 set screws and accelerator position sensor.

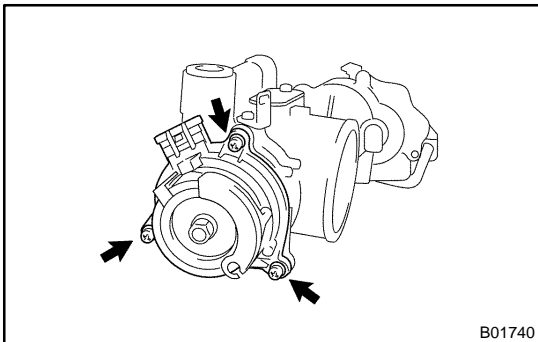

- (b) Reinstall the accelerator pedal position sensor.

- (1) Check that the throttle valve is under the condition of the opener opening angle (about 4°).

- (2) Install the sensor to the place where is at 20° rotated to the left from the specified installation position.

- (3) Gradually turn sensor clockwise until it touches the throttle valve shaft and temporarily torque the 3 set screws.

Torque: 5.4 N·m (55 kgf·cm, 47in.-lbf)

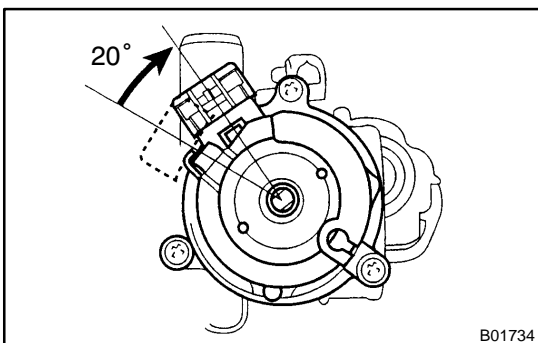

- (c) Inspect the accelerator pedal position sensor.
 - (1) Connect the accelerator pedal position sensor connector.
 - (2) Connect the LEXUS hand-held tester or OBDII scan tool to the DLC3.
 - (3) Turn the ignition switch ON.
 - (4) Check that the ACCEL POS #1 (VPA) voltage of the CURRENT DATA shows the standard value.

**Standard accelerator pedal position voltage:
0.35 – 0.85 V**

NOTICE:

After turning the ignition switch ON, do not depress the accelerator pedal.

4. CHECK SYSTEM OPERATION (See page [SF-36](#))

INSTALLATION

Installation is in the reverse order of removal. (See page [SF-42](#))

CAMSHAFT TIMING OIL CONTROL VALVE

SFOFJ-02

ON-VEHICLE INSPECTION

INSPECT OIL CONTROL VALVE RESISTANCE

- (a) Remove the V-bank cover.
- (b) Remove the battery clamp cover, air cleaner inlet and intake air connector.
- (c) Disconnect the oil control valve connector.
- (d) Using an Ohmmeter, measure the resistance between the terminals.

Resistance: 6.9 – 7.9 Ω at 20°C (68°F)

If the resistance is not as specified, replace the valve.

- (e) Reconnect the oil control valve connector.
- (f) Reinstall the V-bank cover.

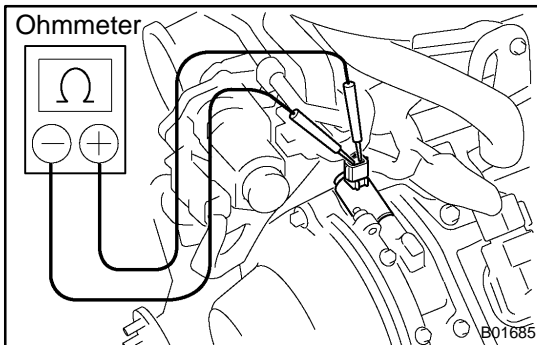

COMPONENTS

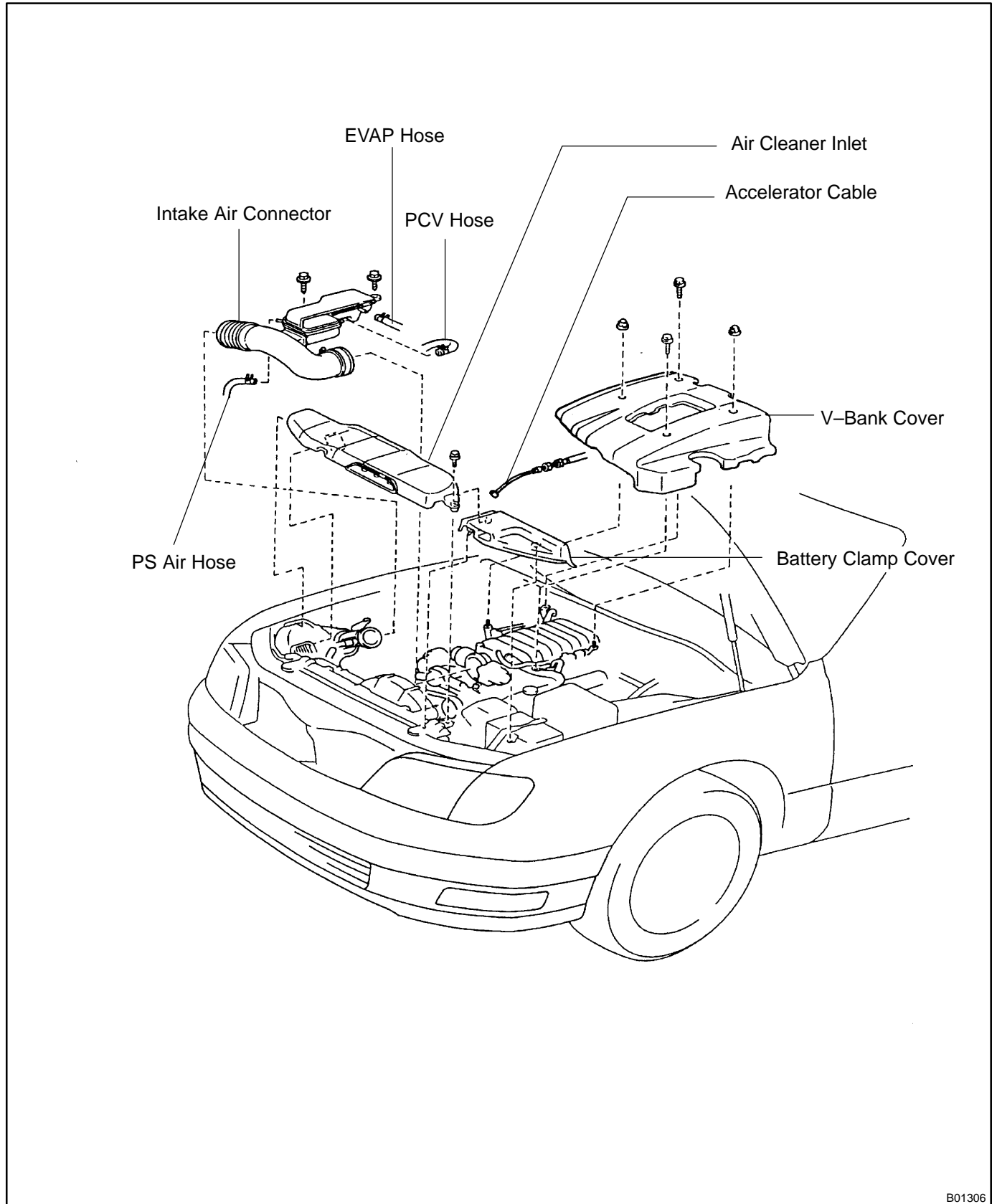

B01306

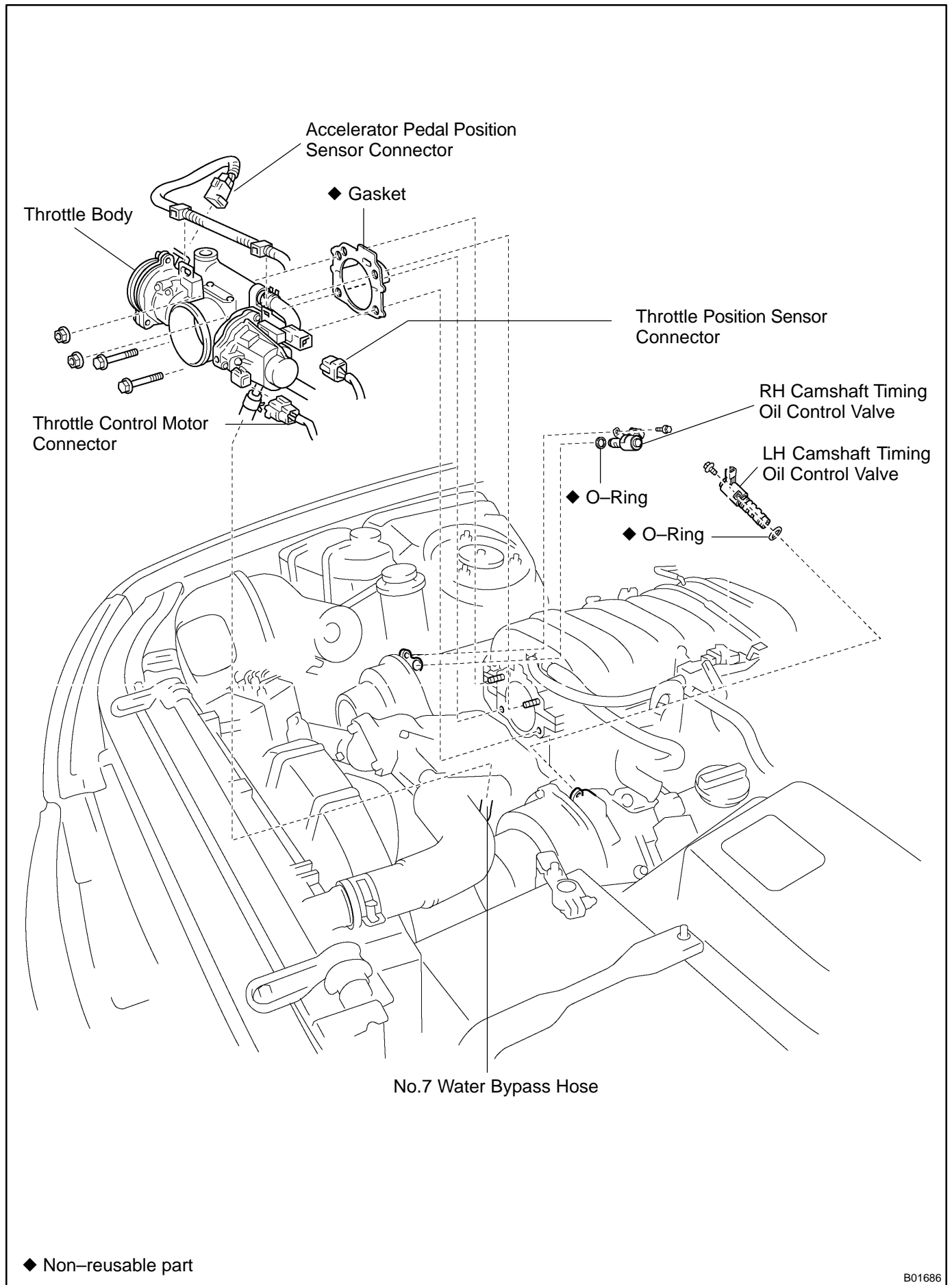

B01686

REMOVAL

1. REMOVE V-BANK COVER
2. REMOVE BATTERY CLAMP COVER, AIR CLEANER INLET AND INTAKE AIR CONNECTOR
3. DISCONNECT THROTTLE BODY FROM INTAKE MANIFOLD (See page SF-59)

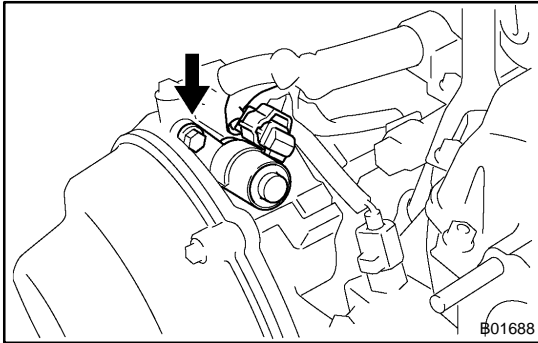

4. REMOVE CAMSHAFT TIMING OIL CONTROL VALVE
 - (a) Disconnect the 2 camshaft oil control valve connectors.
 - (b) Remove the bolt, camshaft oil control valve and O-ring. Remove the 2 camshaft oil control valves.
Torque: 7.5 N·m (80 kgf-cm, 66 in.-lbf)
 - (c) Remove the O-ring from the each camshaft oil control valve.

HINT:

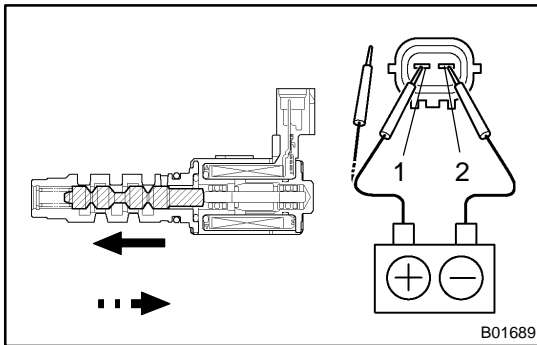

At the time of installation, please refer to the following items.
Use a new O-rings.



INSPECTION

INSPECT OIL CONTROL VALVE OPERATION

Connect positive \oplus lead to terminal 1 of connector and negative \ominus lead to terminal 2, then check the movement of the valve.

When battery positive voltage is applied.	Valve moves in  direction.
When battery positive voltage is cut off.	Valve moves in  direction.

If operation is not as specified, replace the oil control valve.

INSTALLATION

Installation is in the reverse order of removal. (See page [SF-51](#))

ACOUSTIC CONTROL INDUCTION SYSTEM (ACIS)

SF0FO-02

ON-VEHICLE INSPECTION

INSPECT INTAKE AIR CONTROL VALVE

- (a) Remove V-bank cover.
- (b) Remove the battery clamp cover, air cleaner and intake air connector.
- (c) Disconnect the throttle body from the intake manifold.
(See page [SF-59](#))
- (d) Remove the intake manifold. (See page [EM-34](#))

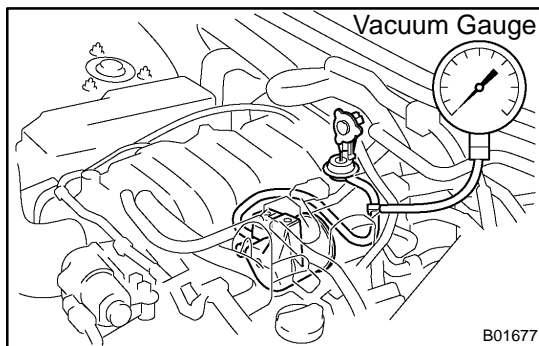

- (e) Using a 3-way connector, connect vacuum gauge to the actuator hose.
- (f) Reinstall the intake manifold.
- (g) Reconnect the throttle body.
- (h) Start the engine.

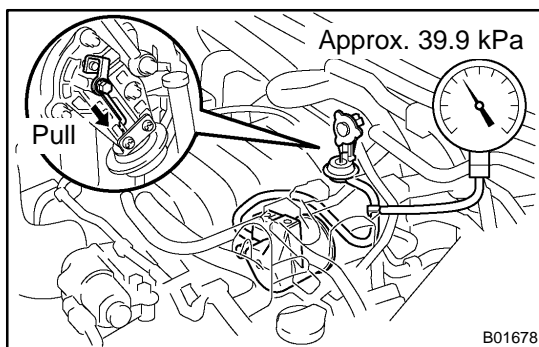

- (i) While the engine is idling, check that the vacuum gauge needle momentarily fluctuates up to approx. 39.9 kPa (300 mmHg, 11.8 in.Hg). (The actuator rod is pulled out.)
- (j) Rapidly depress the accelerator pedal to fully open position and check that the vacuum gauge needle points to 0 kPa (0 mmHg, 0 in.Hg). (The actuator rod is returned.)
- (k) Disconnect the throttle body.
- (l) Remove the intake manifold.
- (m) Remove the vacuum gauge, and connect the vacuum hose to the actuator.
- (n) Reinstall the intake manifold.
- (o) Reconnect the throttle body.
- (p) Reinstall the intake air connector, air cleaner inlet and battery clamp cover.
- (q) Reinstall V-bank cover.

COMPONENTS

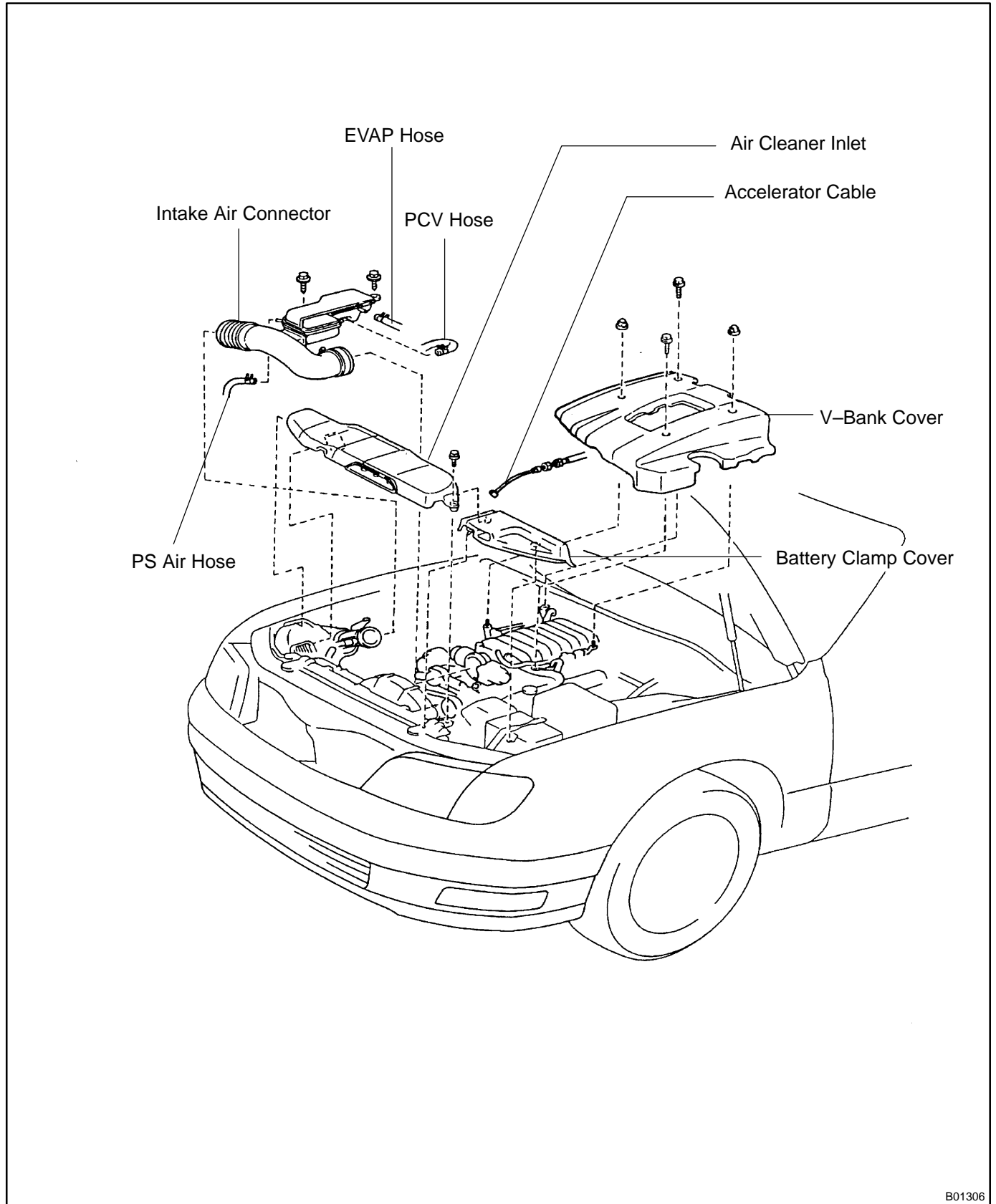

B01306

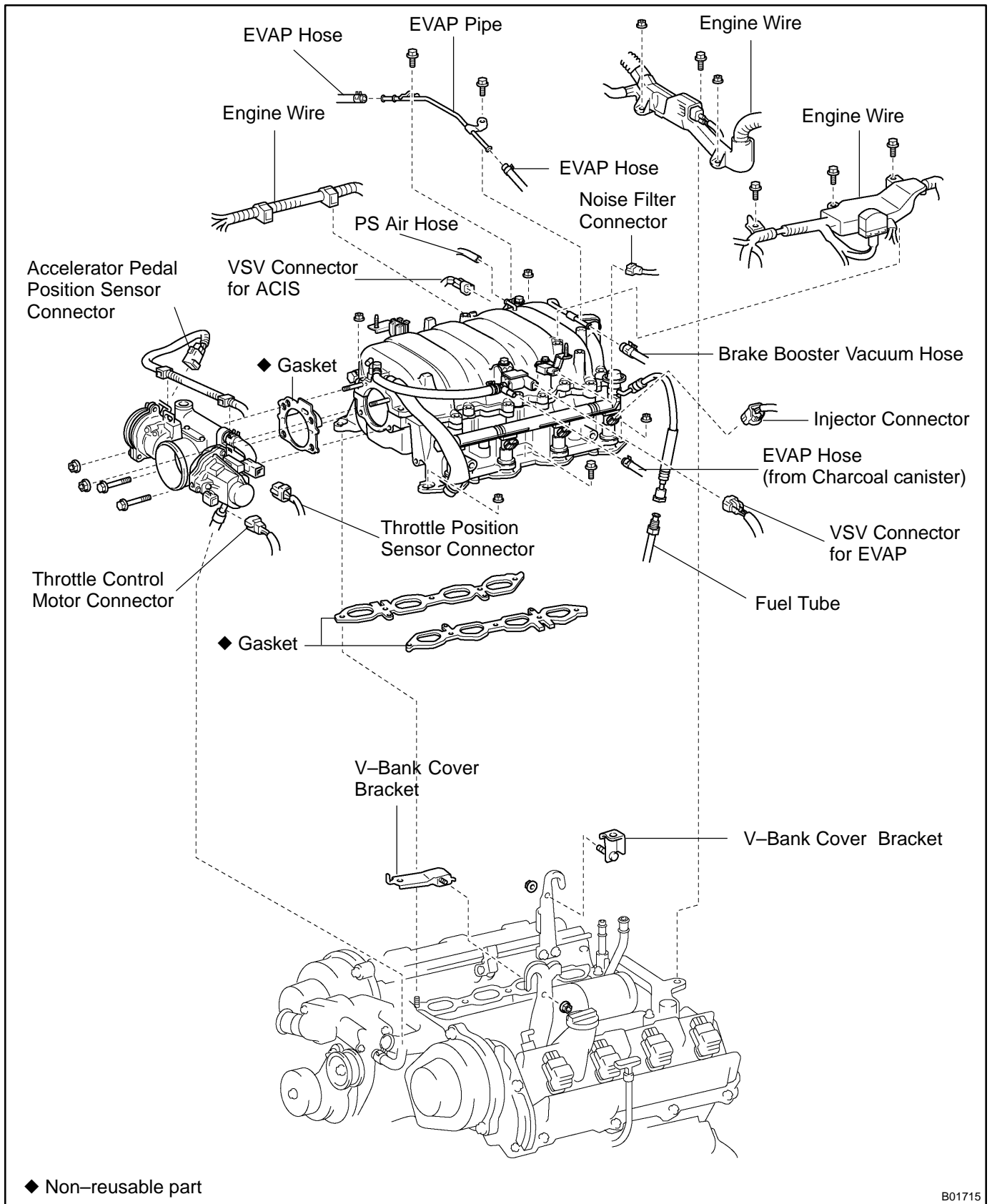

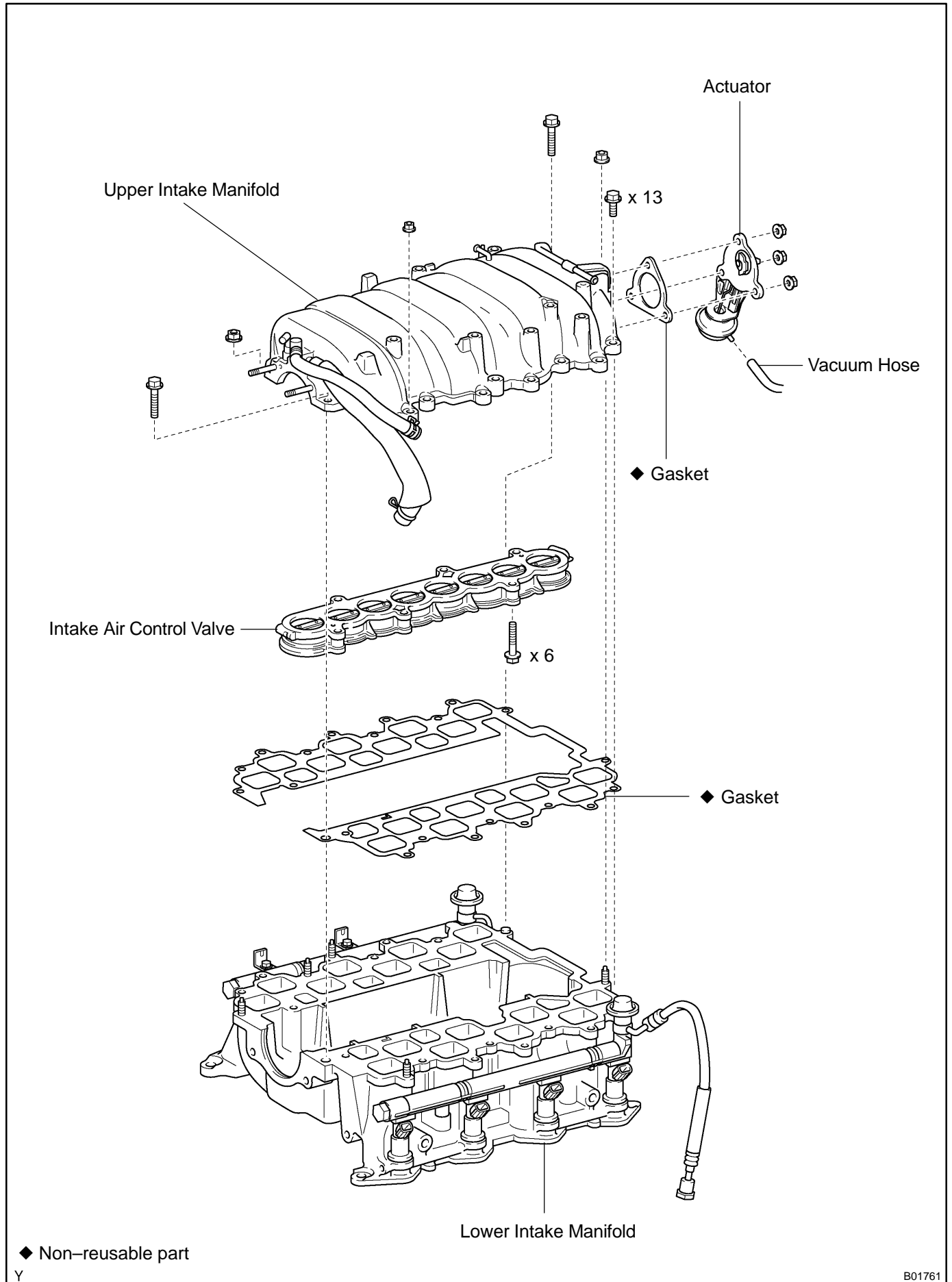

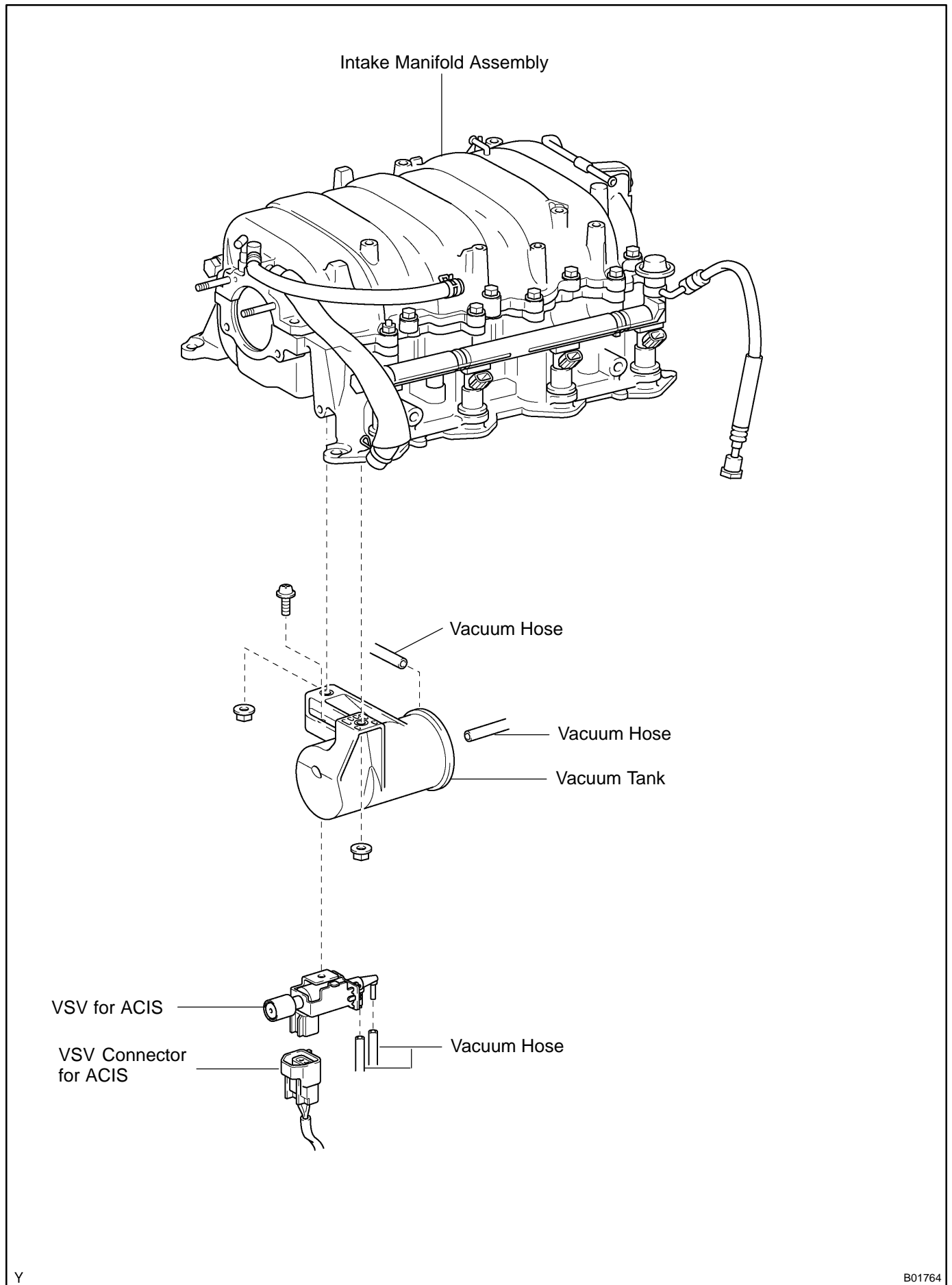

Y

B01764

REMOVAL

1. REMOVE V-BANK COVER
2. REMOVE BATTERY CLAMP COVER, AIR CLEANER INLET AND INTAKE AIR CONNECTOR
3. DISCONNECT THROTTLE BODY FROM INTAKE MANIFOLD

(a) Disconnect the accelerator cable.

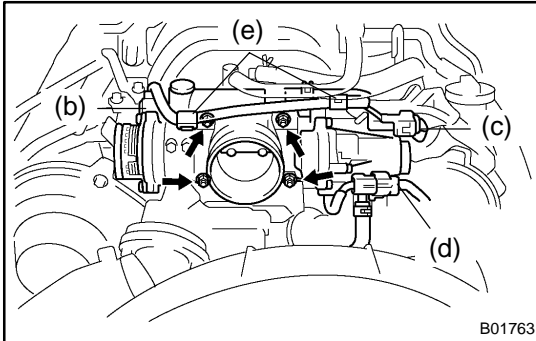

(b) Disconnect the accelerator pedal position sensor connector.

(c) Disconnect the throttle position sensor connector.

(d) Disconnect the throttle control motor connector.

(e) Disconnect the wire clamps.

(f) Remove the 2 bolts and 2 nuts, and disconnect the throttle body.

(g) Remove the gasket.

4. REMOVE INTAKE MANIFOLD ASSEMBLY
(See page [EM-34](#))

5. REMOVE ACTUATOR

(a) Disconnect the vacuum hose from the actuator.

(b) Remove the 3 nuts, actuator and gasket.

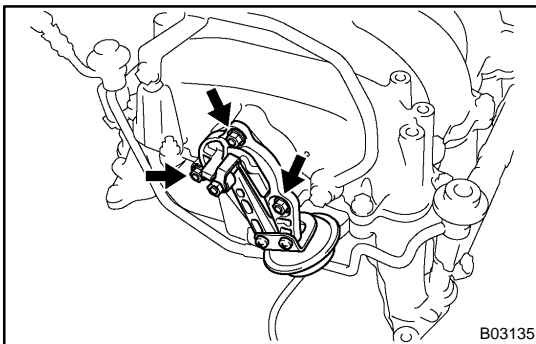

6. REMOVE UPPER INTAKE MANIFOLD

Remove the 3 nuts, 15 bolts, upper intake manifold and gasket.

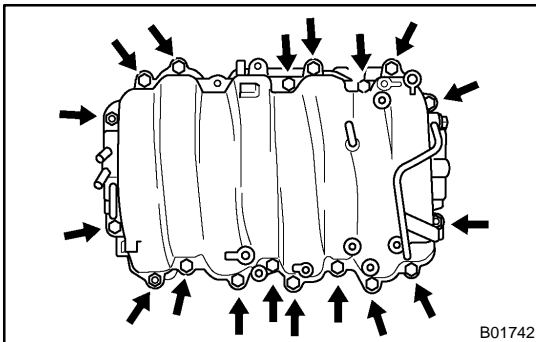

7. REMOVE INTAKE AIR CONTROL VALVE

Remove the 6 bolts and intake air control valve.

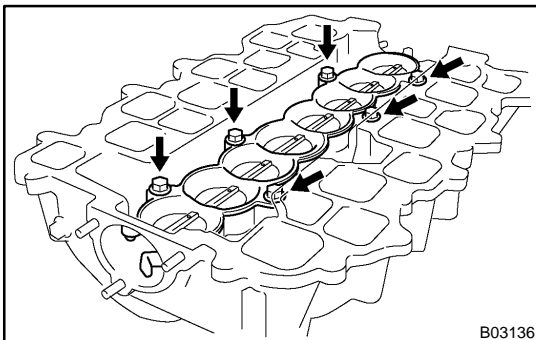

INSPECTION

1. INSPECT INTAKE AIR CONTROL VALVE

- (a) Install the air control valve and actuator to the upper intake manifold. (See page [SF-61](#))

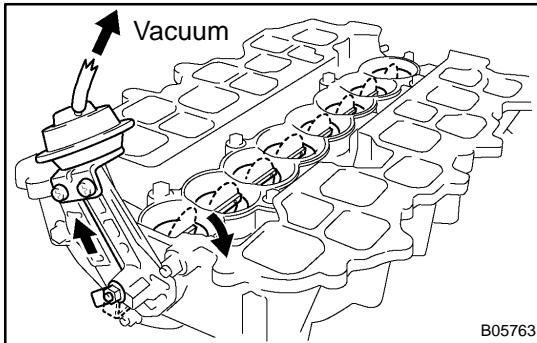

- (b) With 39.9 kPa (300 mmHg, 11.8 in.Hg) of vacuum applied to the actuator, check that the actuator rod moves.
 (c) One minute after applying the vacuum in (a), check that the actuator rod does not return.

If the operation is not as specified, replace the intake air control valve actuator.

2. INSPECT VACUUM TANK

- (a) Remove the vacuum tank.

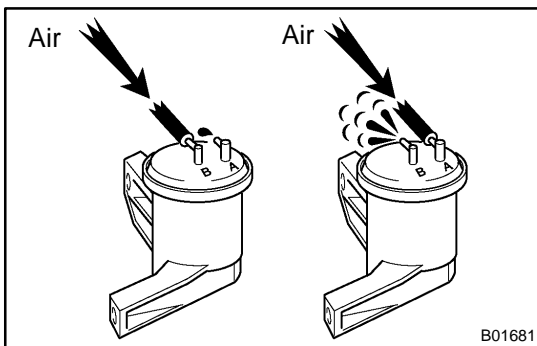

- (b) Check that air does not flow from port B to port A.
 (c) Check that air flows from port A to port B.

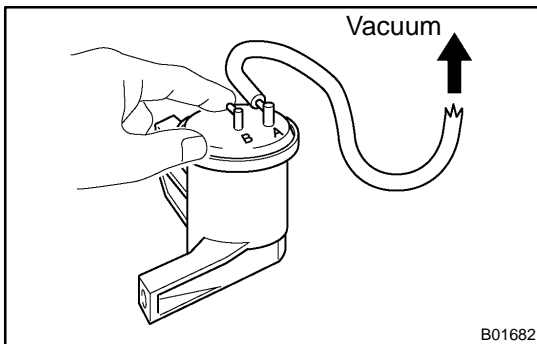

- (d) Plug port B with your finger, and apply 39.9 kPa (300 mmHg, 11.8 in.Hg) of vacuum to port A, and check that there is no change in vacuum after one minute.

If the operation is not as specified, replace the vacuum tank.

- (e) Reinstall the vacuum tank.

3. INSPECT VSV (See page [SF-73](#))

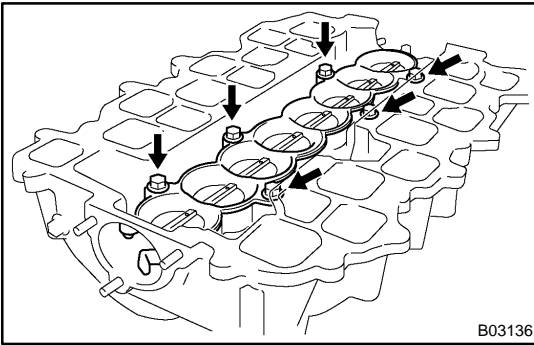

INSTALLATION

1. INSTALL INTAKE AIR CONTROL VALVE

Install the intake air control valve to the upper intake manifold with the 6 bolts.

Torque: 8.5 N·m (85 kgf·cm, 75 in.-lbf)

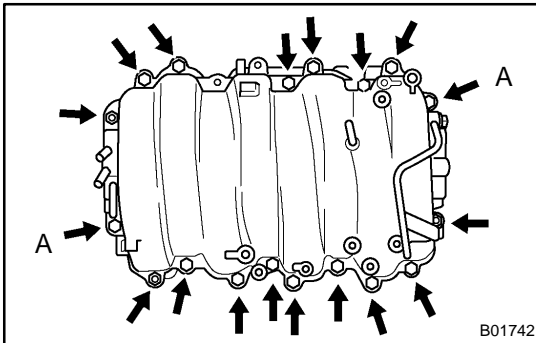

2. INSTALL UPPER INTAKE MANIFOLD

(a) Place a new gasket on the lower intake manifold.

(b) Install the upper intake manifold with the 3 nuts and 15 bolts.

Torque: 18 N·m (185 kgf·cm, 13 ft·lbf)

HINT:

Each bolt length is indicated in the illustration.

Bolt length:

30 mm (1.18 in.) for A

20 mm (0.79 in.) for others

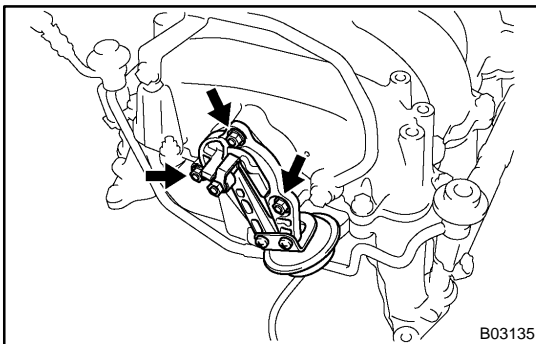

3. INSTALL ACTUATOR

(a) Place a new gasket to the upper intake manifold.

(b) Install the actuator to the upper intake manifold with the 3 nuts.

Torque: 8.5 N·m (85 kgf·cm, 75 in.-lbf)

(c) Connect the vacuum hose to the actuator.

HINT:

Pass the vacuum hose under the fuel pipe.

4. INSTALL INTAKE MANIFOLD ASSEMBLY

(See page [EM-58](#))

5. CONNECT THROTTLE BODY

(a) Place a new gasket to the intake manifold.

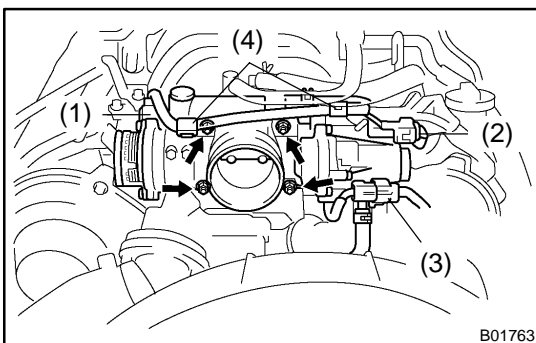

(b) Connect the throttle body with the 2 bolts and 2 nuts.

Torque: 18 N·m (185 kgf·cm, 13 ft·lbf)

(c) Connect the accelerator pedal position sensor connector.

(d) Connect the throttle position sensor connector.

(e) Connect the throttle control motor connector.

(f) Connect the wire clamps.

(g) Connect the accelerator cable.

6. CHECK FOR FUEL LEAKS (See page [SF-1](#))

7. INSTALL INTAKE AIR CONNECTOR, AIR CLEANER INLET AND BATTERY CLAMP COVER

8. INSTALL V-BANK COVER

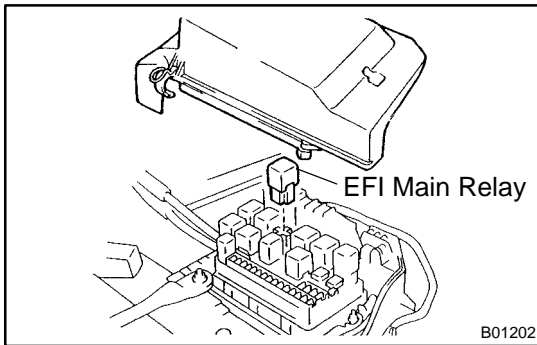

EFI MAIN RELAY INSPECTION

SF0FT-02

1. REMOVE EFI MAIN RELAY (Marking: EFI)

LOCATION: In the engine compartment relay box.

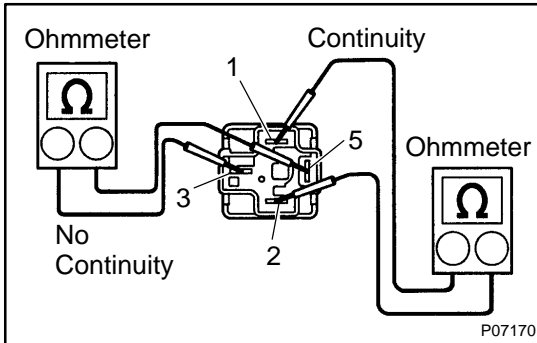

2. INSPECT EFI MAIN RELAY CONTINUITY

(a) Using an ohmmeter, check that there is continuity between terminals 1 and 2.

If there is no continuity, replace the relay.

(b) Check that there is no continuity between terminals 3 and 5.

If there is continuity, replace the relay.

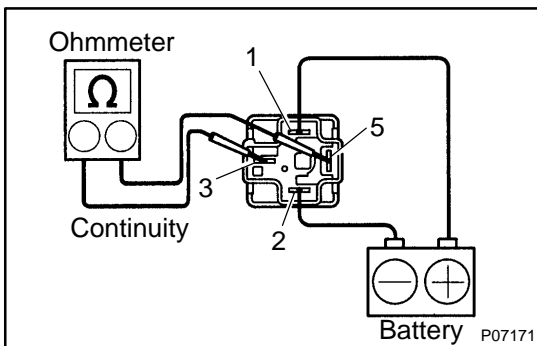

3. INSPECT EFI MAIN RELAY OPERATION

(a) Apply battery voltage across terminals 1 and 2.

(b) Using an ohmmeter, check that there is continuity between terminals 3 and 5.

If there is no continuity, replace the relay.

4. REINSTALL EFI MAIN RELAY

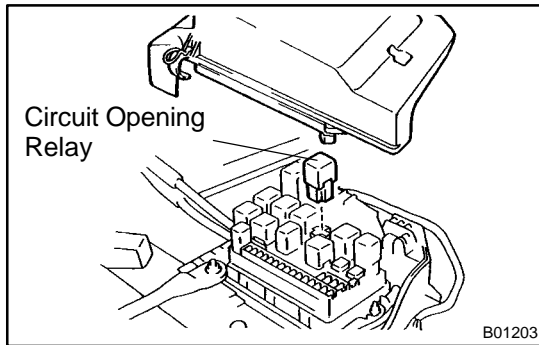

CIRCUIT OPENING RELAY INSPECTION

SFOFU-02

1. REMOVE CIRCUIT OPENING RELAY (Marking: CIR OPN)

LOCATION: In the engine compartment relay box.

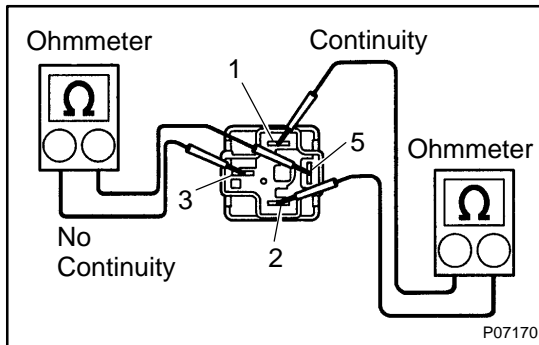

2. INSPECT CIRCUIT OPENING RELAY CONTINUITY

- (a) Using an ohmmeter, check that there is continuity between terminals 1 and 2.

If there is no continuity, replace the relay.

- (b) Check that there is no continuity between terminals 3 and 5.

If there is continuity, replace the relay.

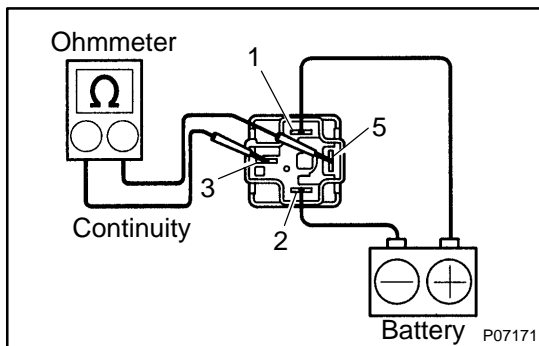

3. INSPECT CIRCUIT OPENING RELAY OPERATION

- (a) Apply battery voltage across terminals 1 and 2.

- (b) Using an ohmmeter, check that there is continuity between terminals 3 and 5.

If there is no continuity, replace the relay.

4. REINSTALL CIRCUIT OPENING RELAY

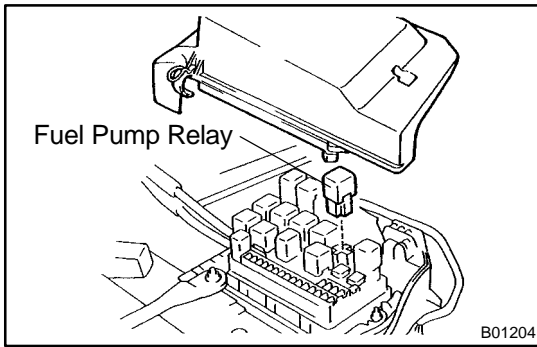

FUEL PUMP RELAY INSPECTION

SF0FV-02

1. REMOVE FUEL PUMP RELAY (Marking: FUEL PUMP)

LOCATION: In the engine compartment relay box.

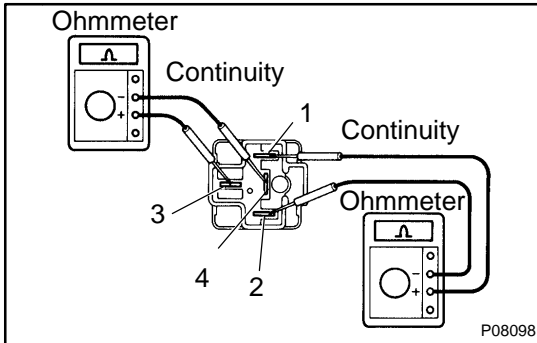

2. INSPECT FUEL PUMP RELAY CONTINUITY

- (a) Using an ohmmeter, check that there is continuity between terminals 1 and 2.

If there is no continuity, replace the relay.

- (b) Check that there is continuity between terminals 3 and 4.

If there is no continuity, replace the relay.

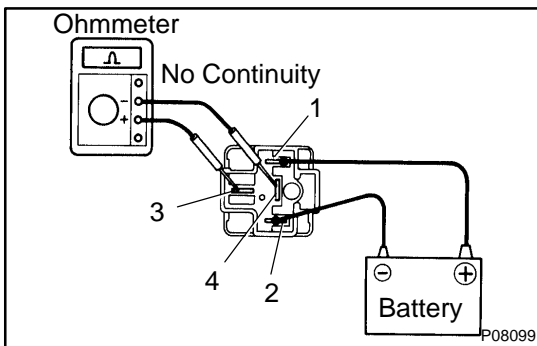

3. INSPECT FUEL PUMP RELAY OPERATION

- (a) Apply battery voltage across terminals 1 and 2.

- (b) Using an ohmmeter, check that there is no continuity between terminals 3 and 4.

If there is continuity, replace the relay.

4. REINSTALL FUEL PUMP RELAY

FUEL PUMP RESISTOR COMPONENTS

SF0FW-02

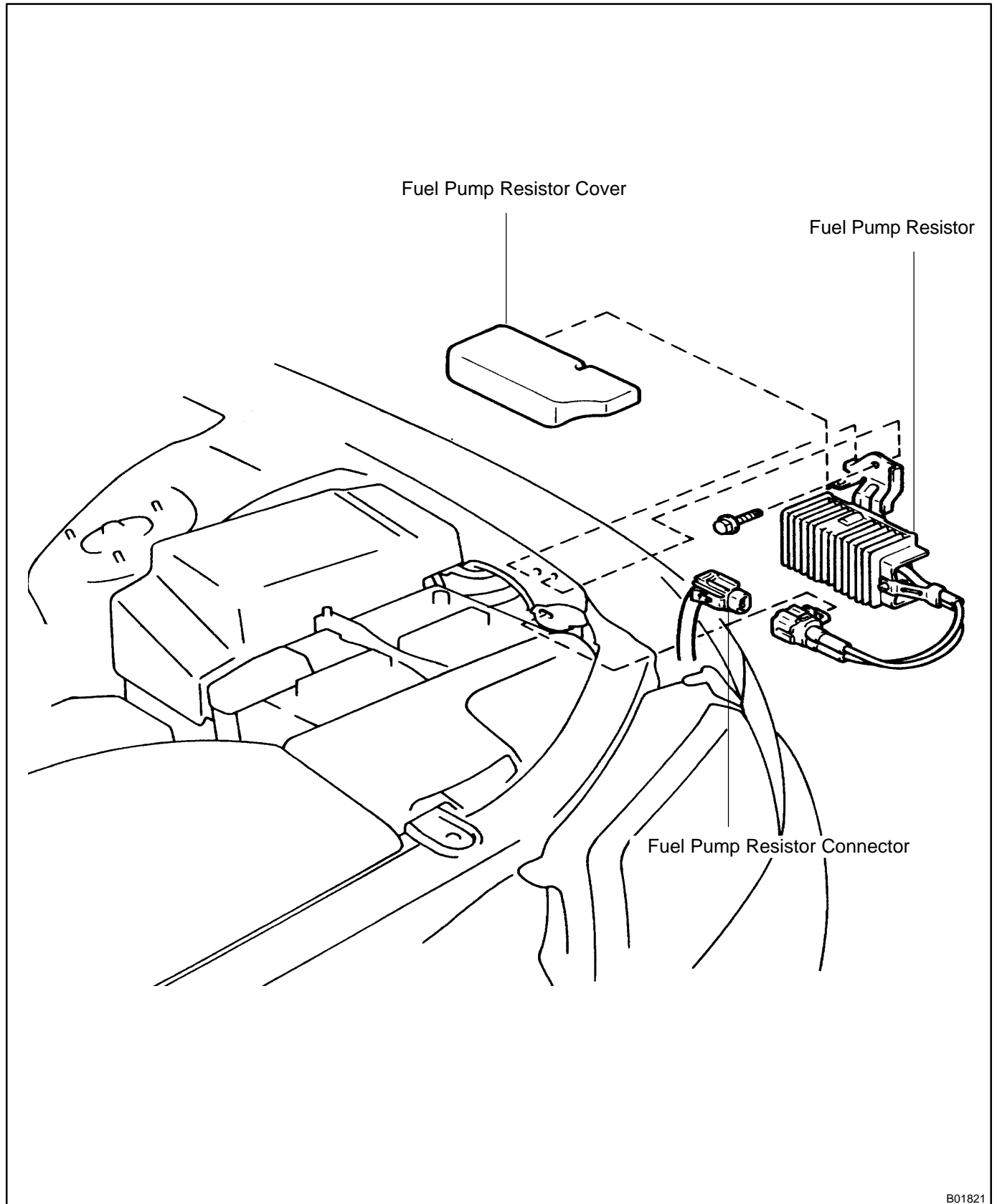

B01821

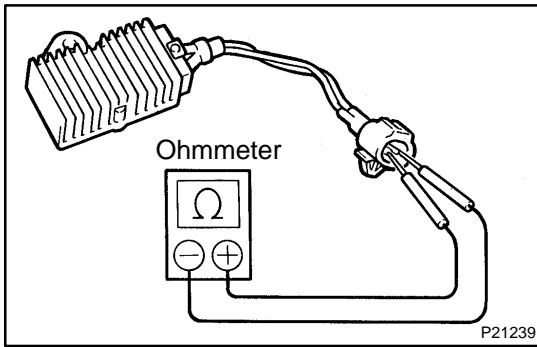

INSPECTION

INSPECT FUEL PUMP RESISTOR

Using an ohmmeter, measure the resistance between the terminals.

Resistance: 0.70 – 0.76 Ω at 20°C (68°F)

If the resistance is not as specified, replace the resistor.

VSV FOR EVAPORATIVE EMISSION (EVAP) COMPONENTS

SFOFY-02

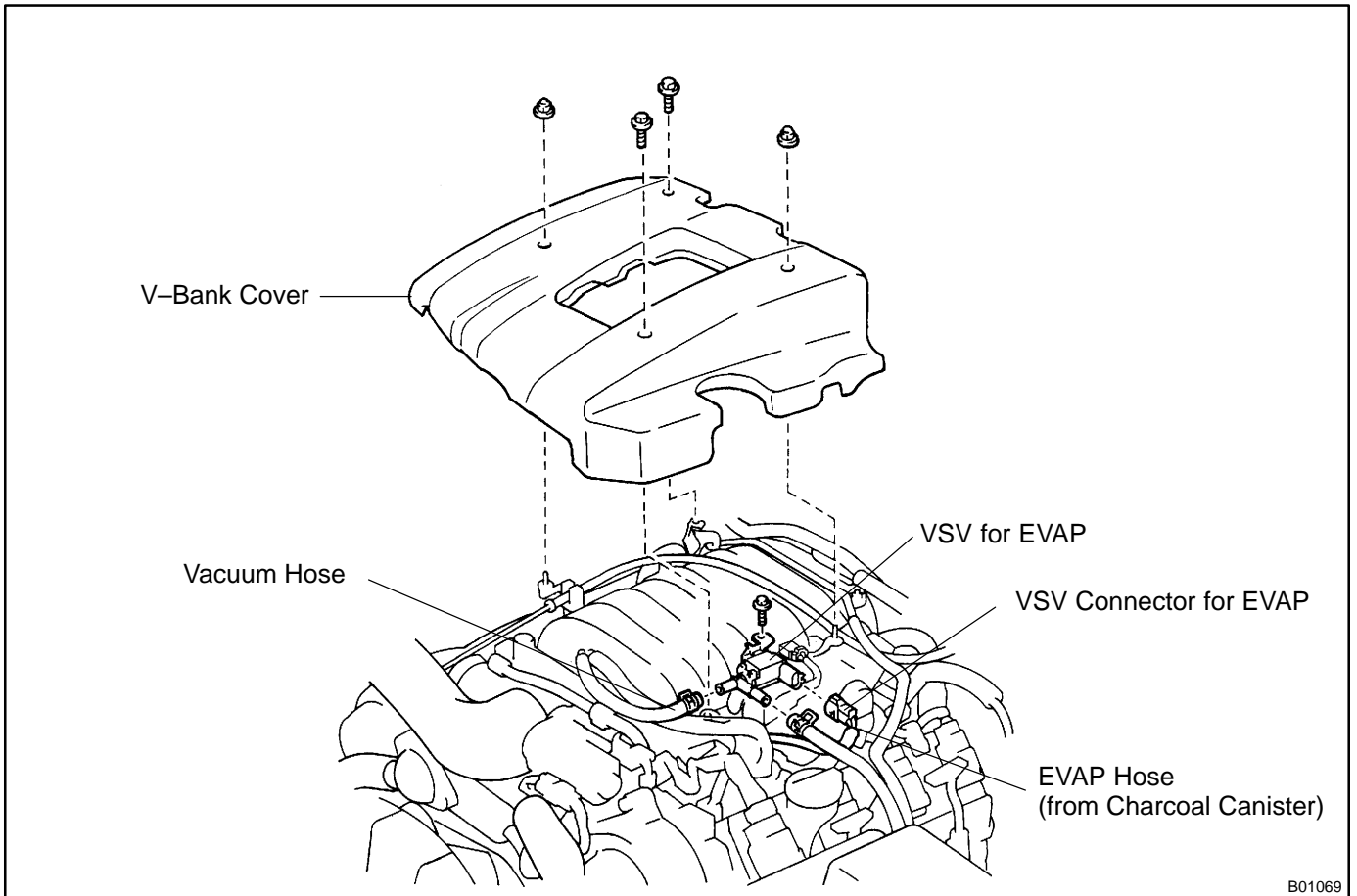

B01069

INSPECTION

1. REMOVE V-BANK COVER
2. REMOVE VSV FOR EVAP

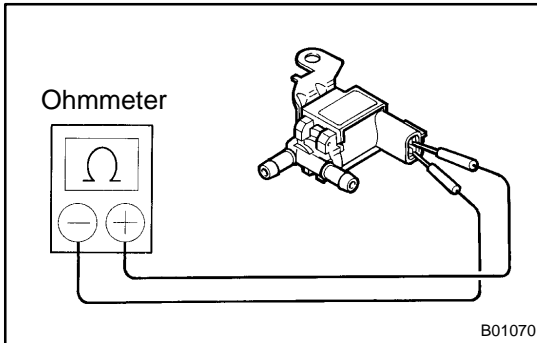

3. INSPECT VSV FOR OPEN CIRCUIT

Using an ohmmeter, check that there is continuity between the terminals.

Resistance: 30 – 34 Ω at 20°C (68°F)

If there is no continuity, replace the VSV.

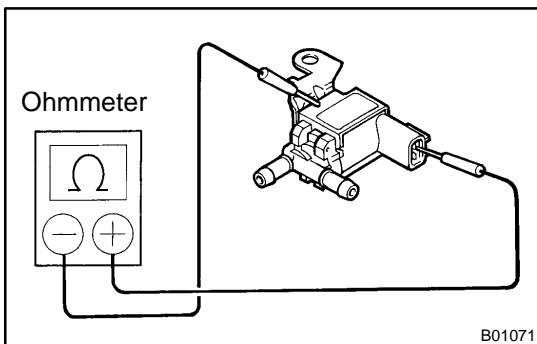

4. INSPECT VSV FOR GROUND

Using an ohmmeter, check that there is no continuity between each terminal and the body.

If there is continuity, replace the VSV.

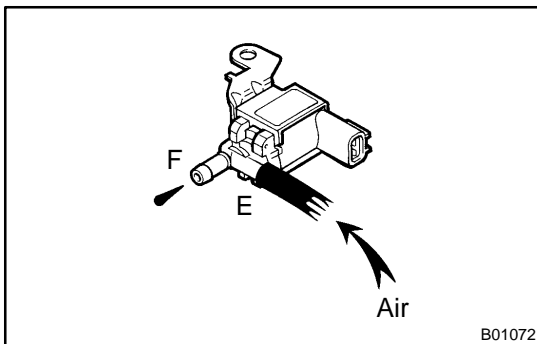

5. INSPECT VSV OPERATION

- (a) Check that the air flows with difficulty from port E to F.

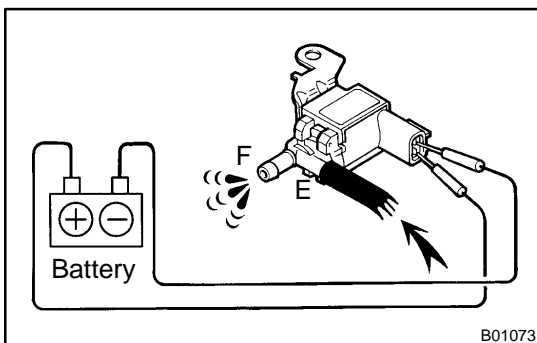

- (b) Apply battery voltage across the terminals.

- (c) Check that the air flows without resistance from port E to F.

If operation is not as specified, replace the VSV.

6. REINSTALL VSV

Torque: 18 N·m (185 kgf·cm, 13 ft·lbf)

7. REINSTALL V-BANK COVER

VSV FOR ACOUSTIC CONTROL INDUCTION SYSTEM (ACIS) COMPONENTS

SF030-02

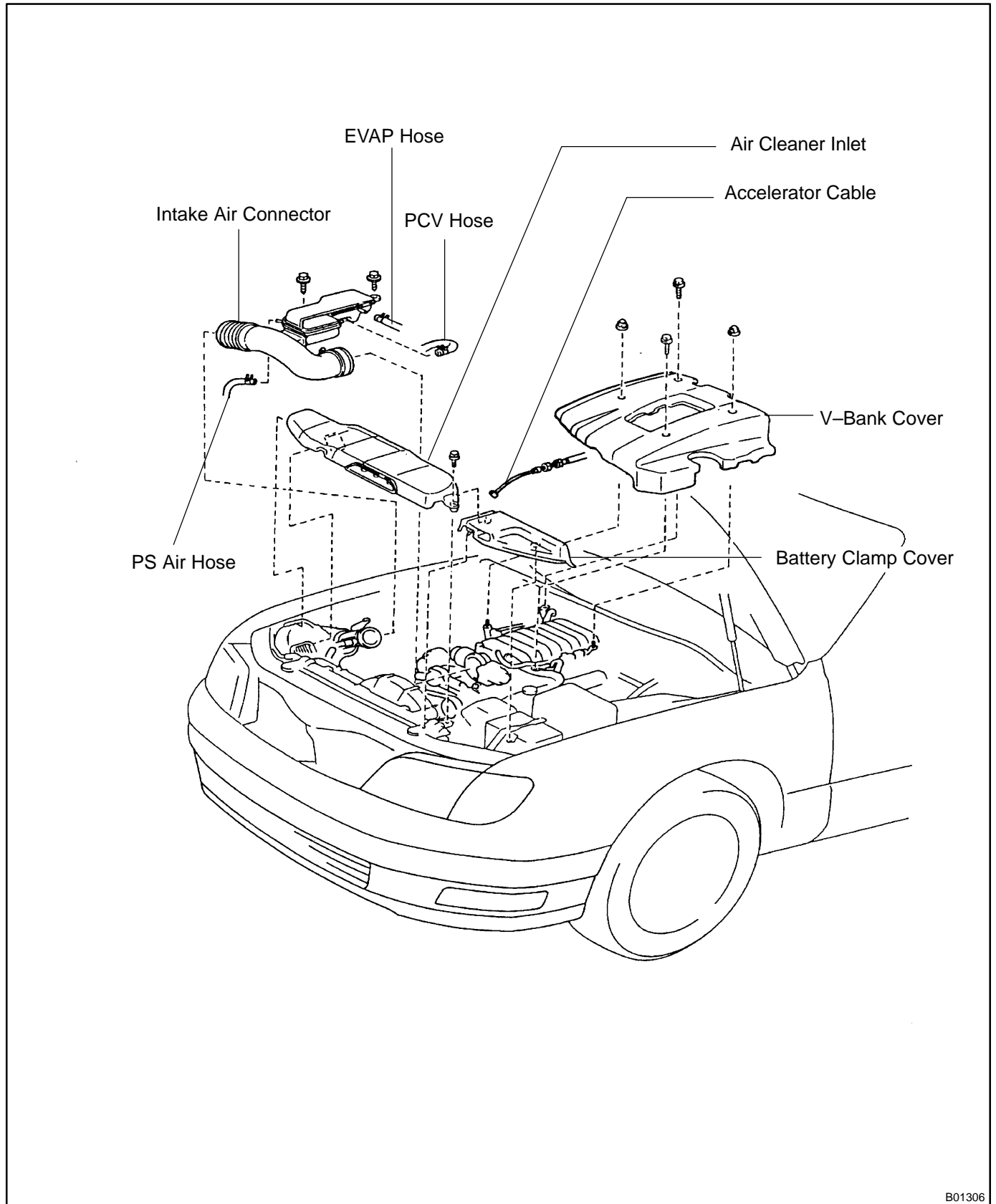

B01306

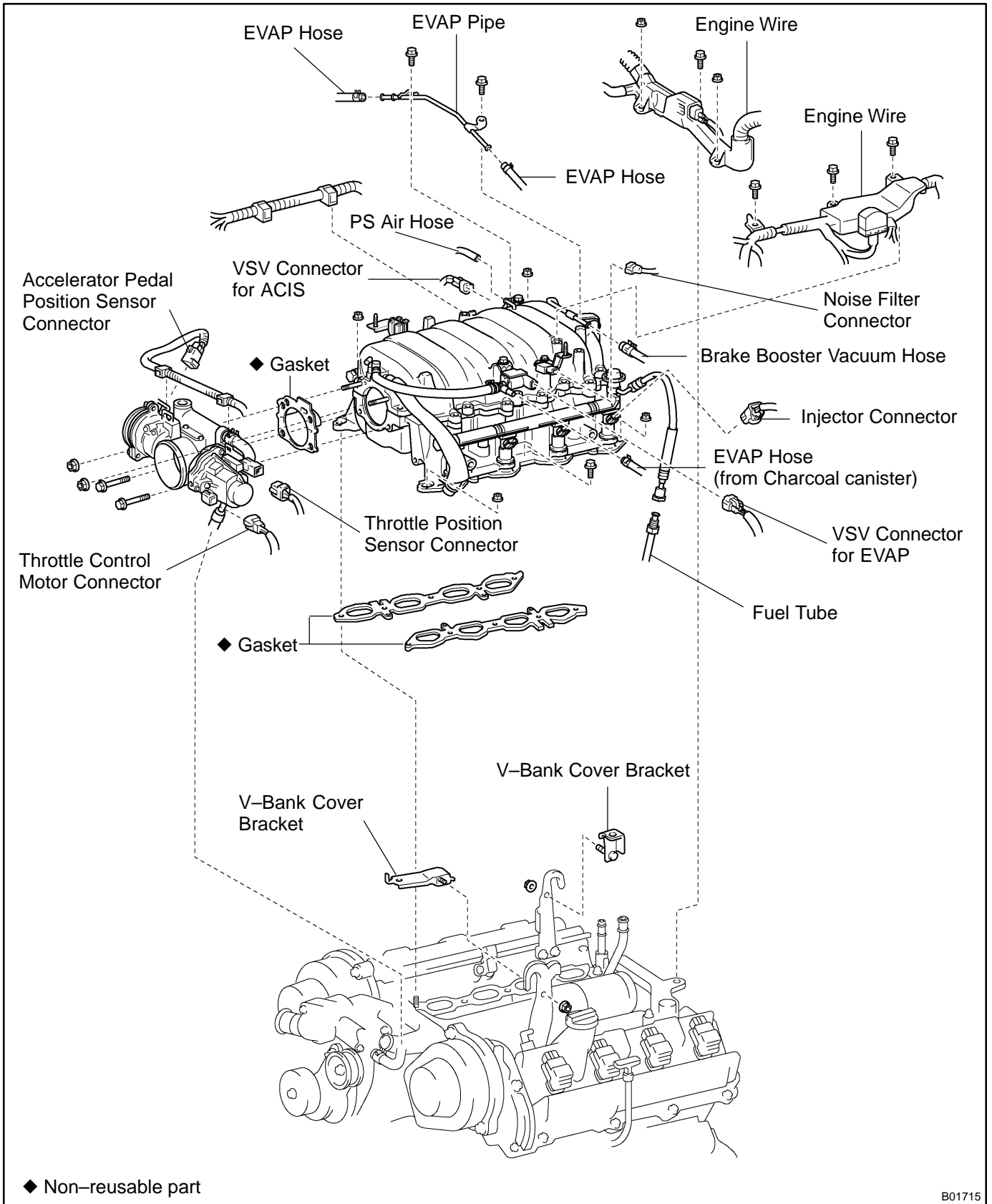

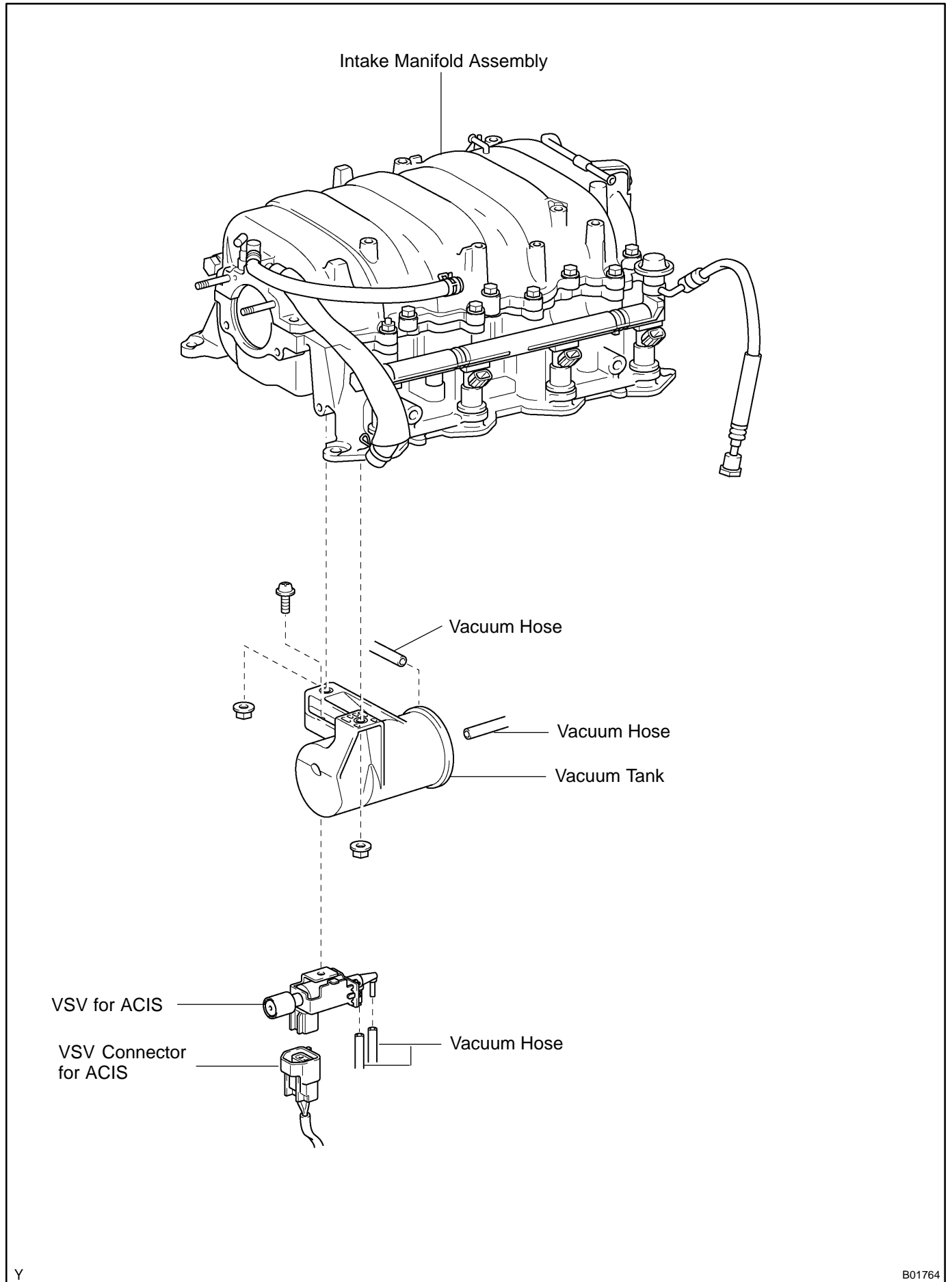

Y

B01764

INSPECTION

1. REMOVE V-BANK COVER
2. REMOVE BATTERY CLAMP COVER, AIR CLEANER INLET AND INTAKE AIR CONNECTOR
3. DISCONNECT THROTTLE BODY (See page SF-59)
4. REMOVE INTAKE MANIFOLD ASSEMBLY (See page EM-34)
5. REMOVE VACUUM TANK
6. REMOVE VSV
 - (a) Disconnect the 2 vacuum hoses and connector from the VSV.
 - (b) Remove the screw and VSV.

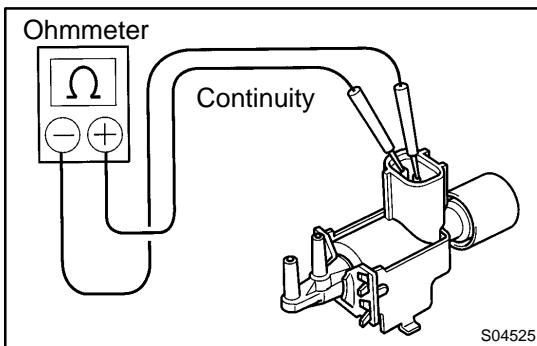

7. INSPECT VSV FOR OPEN CIRCUIT

Using an ohmmeter, check that there is continuity between each terminals.

Resistance: 33 – 39 Ω at 20°C (68°F)

If there is no continuity, replace the VSV.

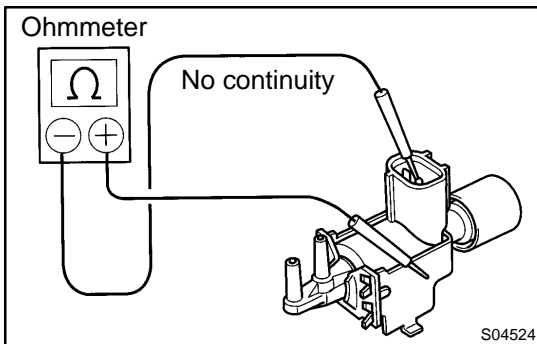

8. INSPECT VSV FOR GROUND

Using an ohmmeter, check that there is no continuity between each terminal and the body.

If there is continuity, replace the VSV.

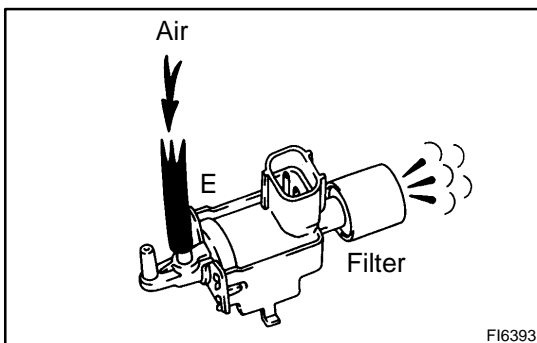

9. INSPECT VSV OPERATION

- (a) Check that air flows from port E to the filter

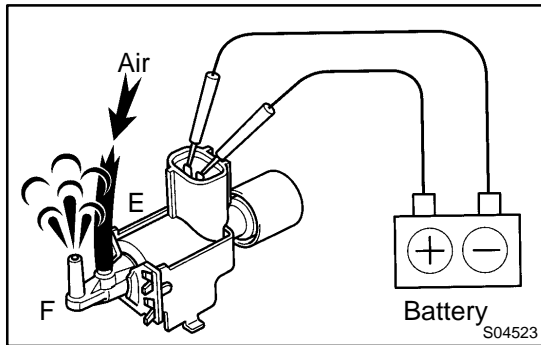

- (b) Apply battery voltage across the terminals.
 - (c) Check that air flows from port E to port F.
- If operation is not as specified, replace the VSV.

10. REINSTALL VSV

- (a) Install the VSV with the screw.
- (b) Connect the 2 vacuum to the VSV.

11. REINSTALL VACUUM TANK

12. REINSTALL INTAKE MANIFOLD ASSEMBLY

(See page [EM-58](#))

- 13. RECONNECT THROTTLE BODY (See page [SF-61](#))**
- 14. CHECK FOR FUEL LEAKS (See page [SF-1](#))**
- 15. REINSTALL INTAKE AIR CONNECTOR, AIR CLEANER INLET AND BATTERY CLAMP COVER**
- 16. REINSTALL V-BANK COVER**

VSV FOR CANISTER CLOSED VALVE (CCV) COMPONENTS

SF195-01

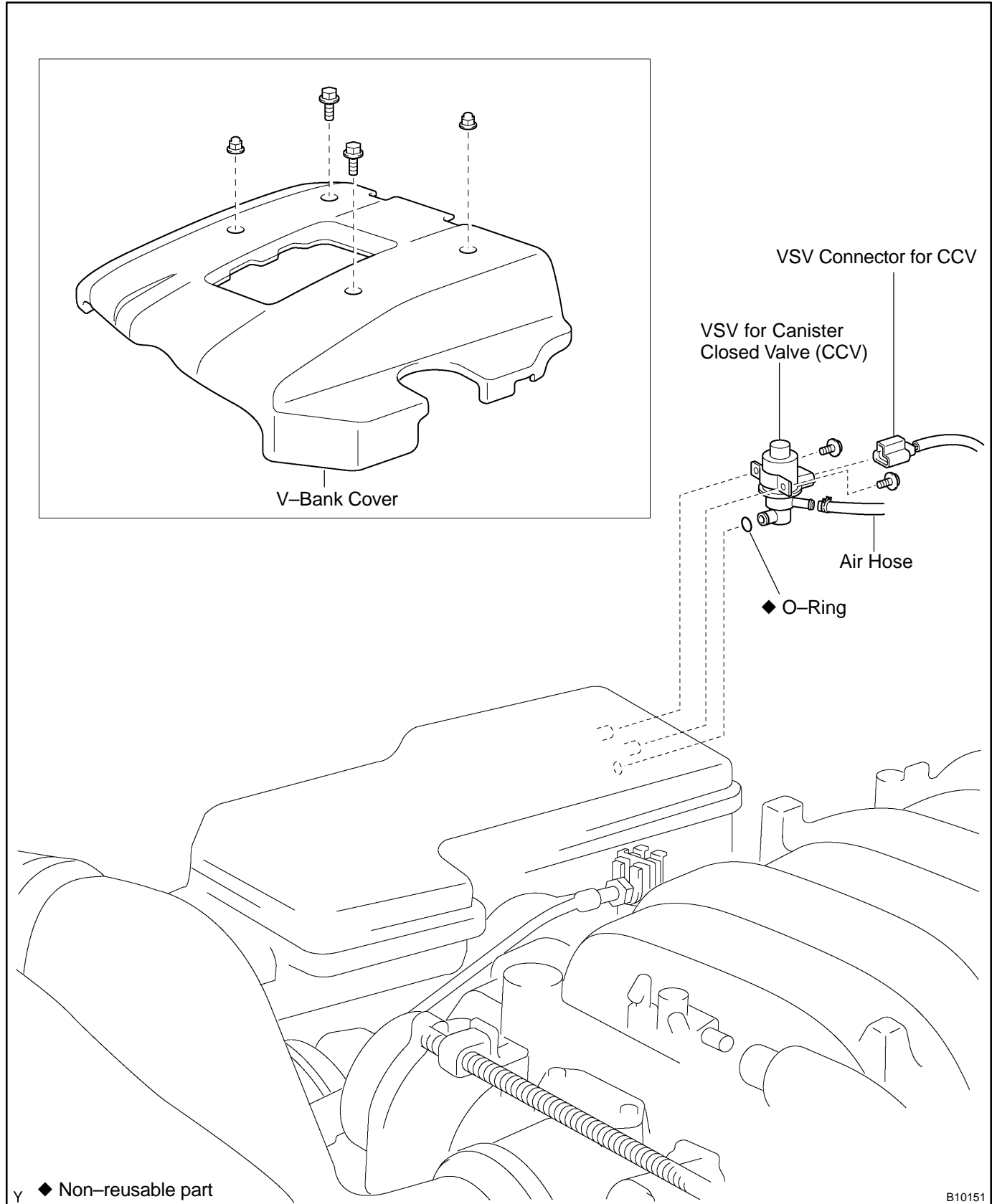

INSPECTION

1. REMOVE VSV

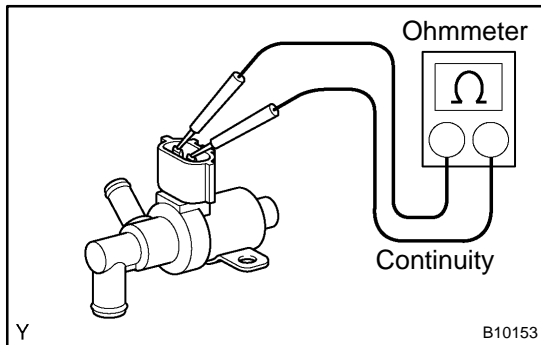

2. INSPECT VSV FOR OPEN CIRCUIT

Using an ohmmeter, check that there is continuity between the terminals.

Resistance:

At 20°C (68°F)	25 – 30 Ω
At 120°C (248°F)	33 – 42 Ω

If there is no continuity, replace the VSV.

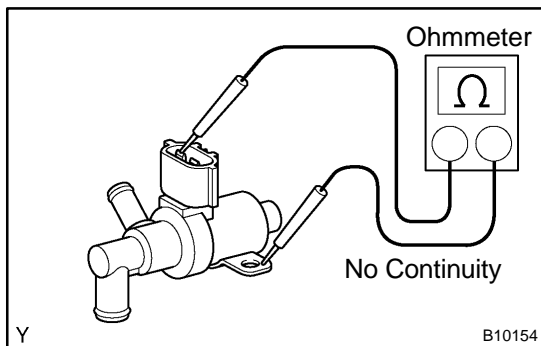

3. INSPECT VSV FOR GROUND

Using an ohmmeter, check that there is no continuity between each terminal and the body.

If there is continuity, replace the VSV.

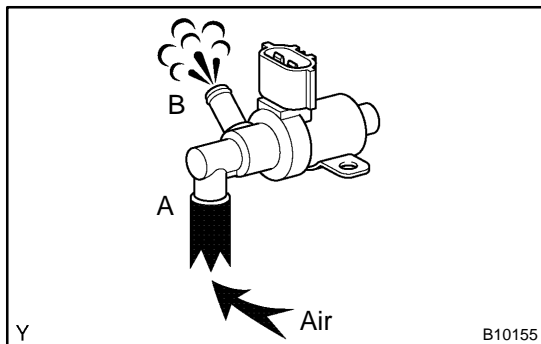

4. INSPECT VSV OPERATION

(a) Check that air flows from ports A to B.

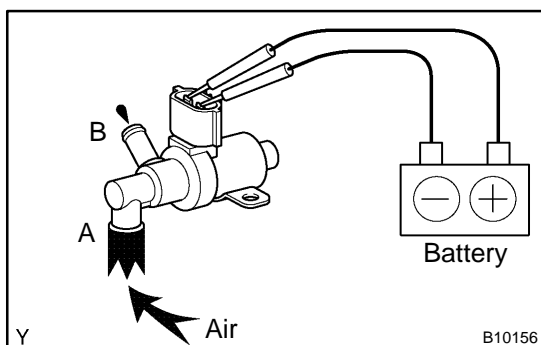

(b) Apply battery positive voltage across the terminals.

(c) Check that air does not flow from ports A to B.

If operation is not as specified, replace the VSV.

5. REINSTALL VSV

VSV FOR PRESSURE SWITCHING VALVE

INSPECTION

SF197-01

1. REMOVE CHARCOAL CANISTER (See page EC-7)

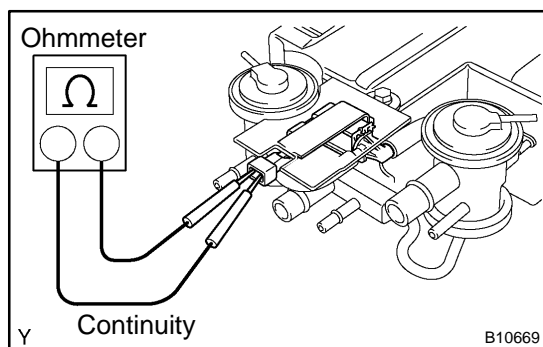

2. INSPECT VSV FOR OPEN CIRCUIT

Using an ohmmeter, check that there is continuity between the terminals.

Resistance:

At 20°C (68°F)	37 – 44 Ω
At 120°C (248°F)	51 – 62 Ω

If there is no continuity, replace the VSV.

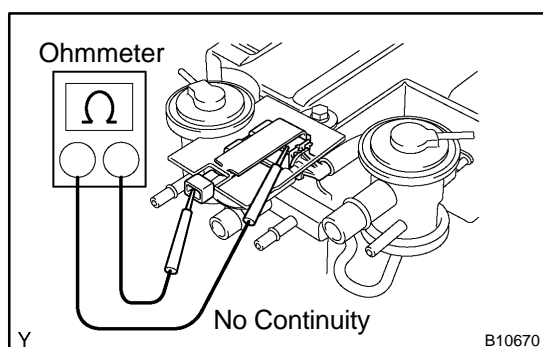

3. INSPECT VSV FOR GROUND

Using an ohmmeter, check that there is no continuity between each terminal and the body.

If there is continuity, replace the VSV.

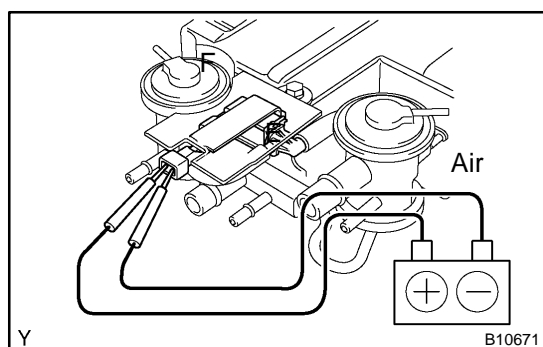

4. INSPECT VSV FOR OPERATING SOUND

- Apply battery positive voltage across the terminals.
- Check that there is a operating sound.

If operation is not as specified, replace the charcoal canister assembly.

5. REINSTALL CHARCOAL CANISTER (See page EC-7)

ENGINE COOLANT TEMPERATURE (ECT) SENSOR COMPONENTS

SF0G3-02

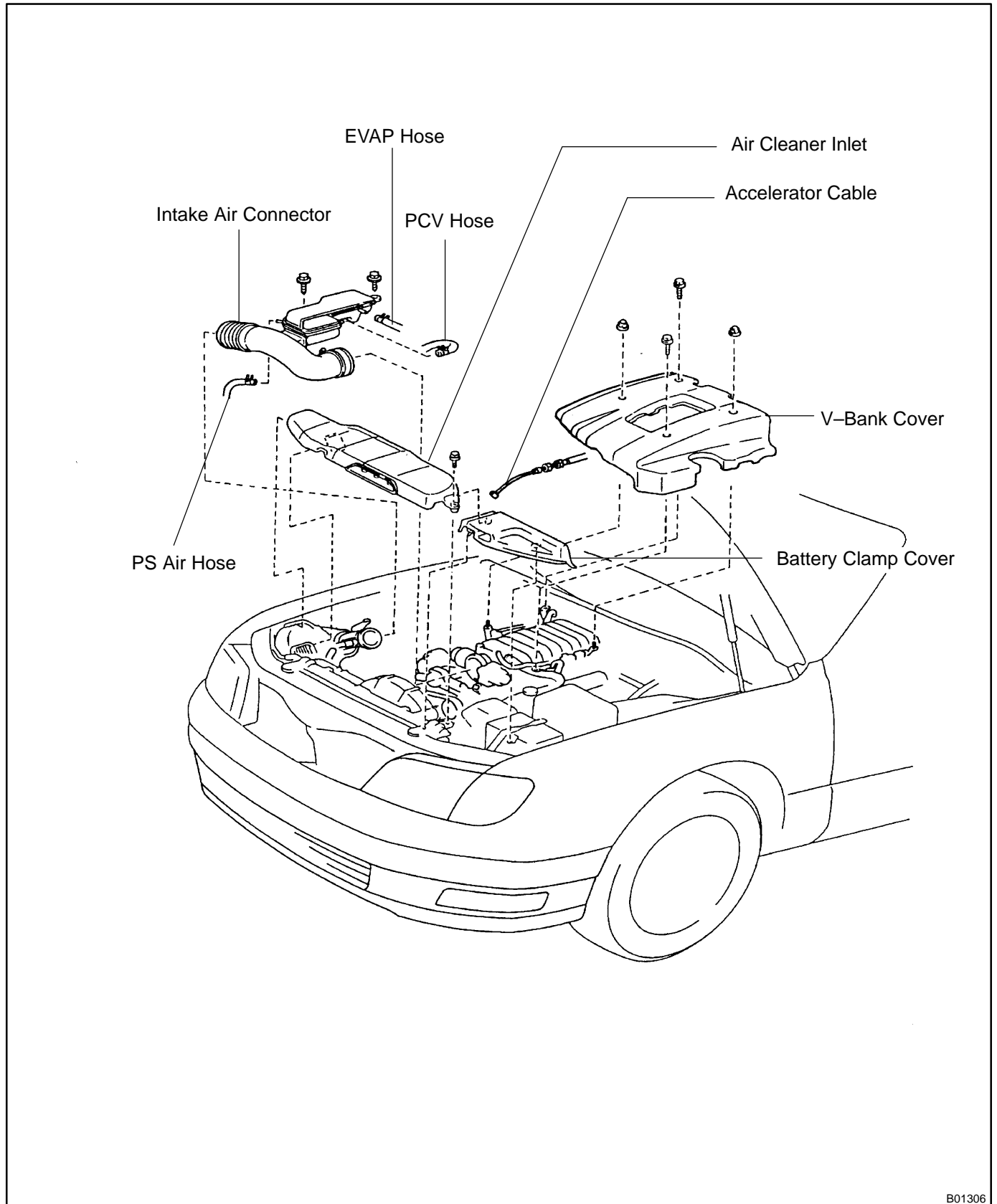

B01306

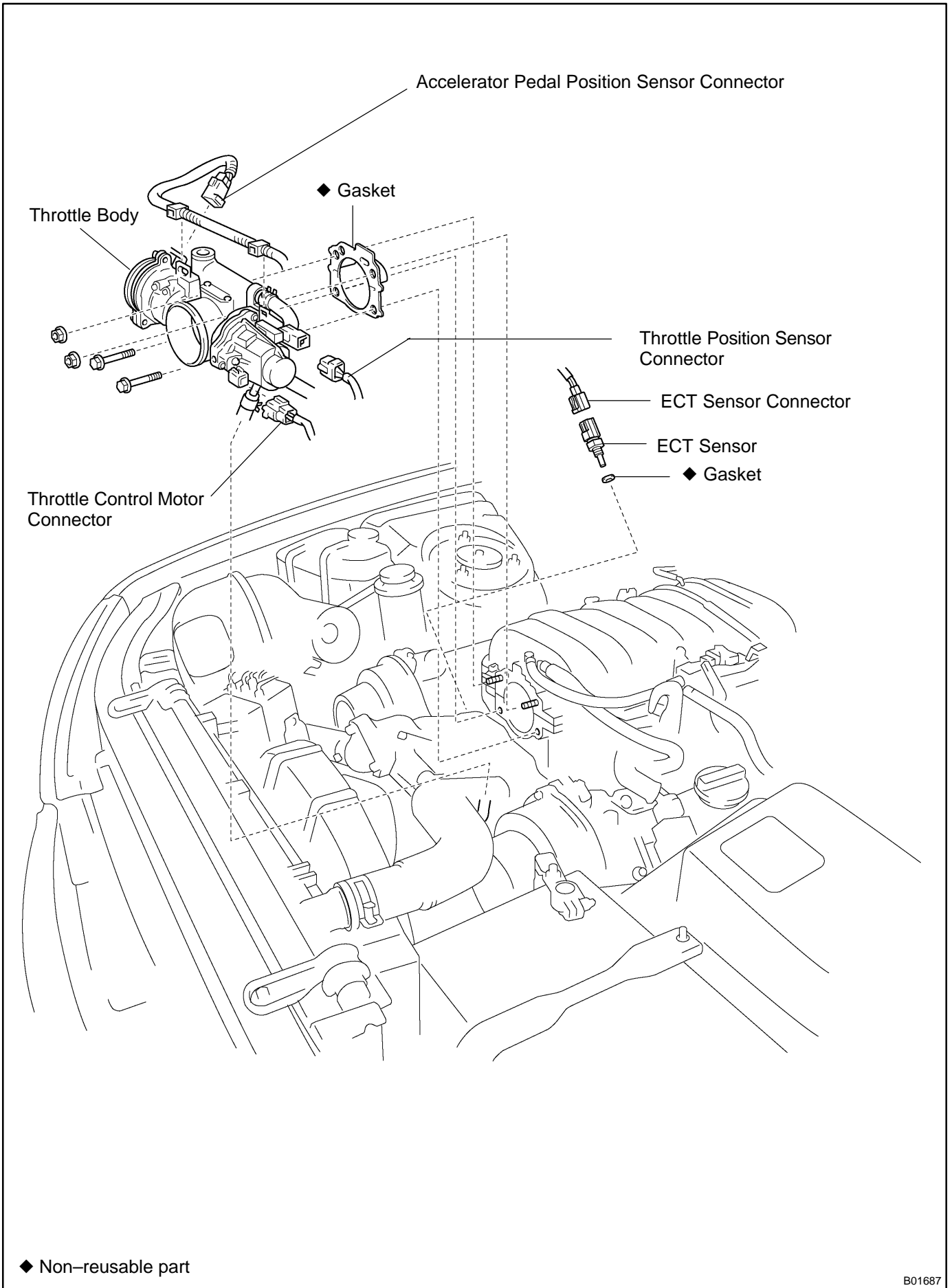

B01687

INSPECTION

1. REMOVE V-BANK COVER
2. REMOVE BATTERY CLAMP COVER, AIR CLEANER INLET AND INTAKE AIR CONNECTOR
3. DRAIN ENGINE COOLANT
4. DISCONNECT THROTTLE BODY (See page SF-59)

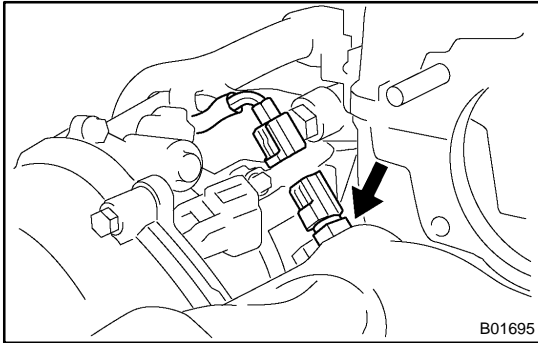

5. REMOVE ECT SENSOR
 - (a) Disconnect the ECT sensor connector.
 - (b) Remove the ECT sensor and gasket.

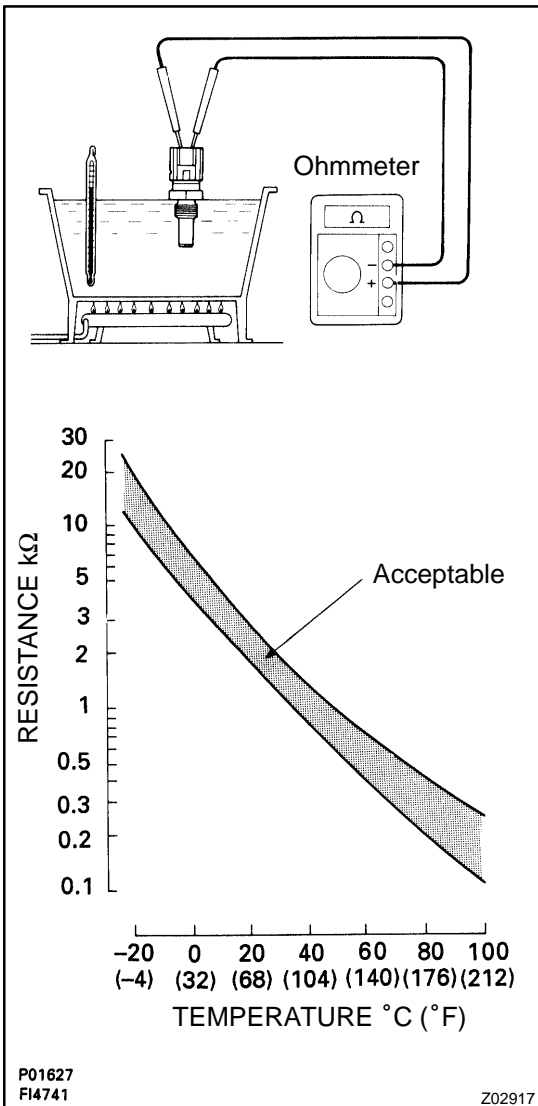

6. INSPECT ECT SENSOR

Using an ohmmeter, measure the resistance between the terminals.

Resistance: Refer to the chart graph

If the resistance is not as specified, replace the sensor.

7. REINSTALL ECT SENSOR

- (a) Install a new gasket and the ECT sensor.
Torque: 20 N·m (200 kgf·cm, 14 ft·lbf)
- (b) Connect the ECT sensor connector.

8. RECONNECT THROTTLE BODY (See page SF-61)

9. REFILL WITH ENGINE COOLANT

10. REINSTALL INTAKE AIR CONNECTOR, AIR CLEANER INLET AND BATTERY CLAMP COVER

11. REINSTALL V-BANK COVER

VAPOR PRESSURE SENSOR COMPONENTS

SF198-01

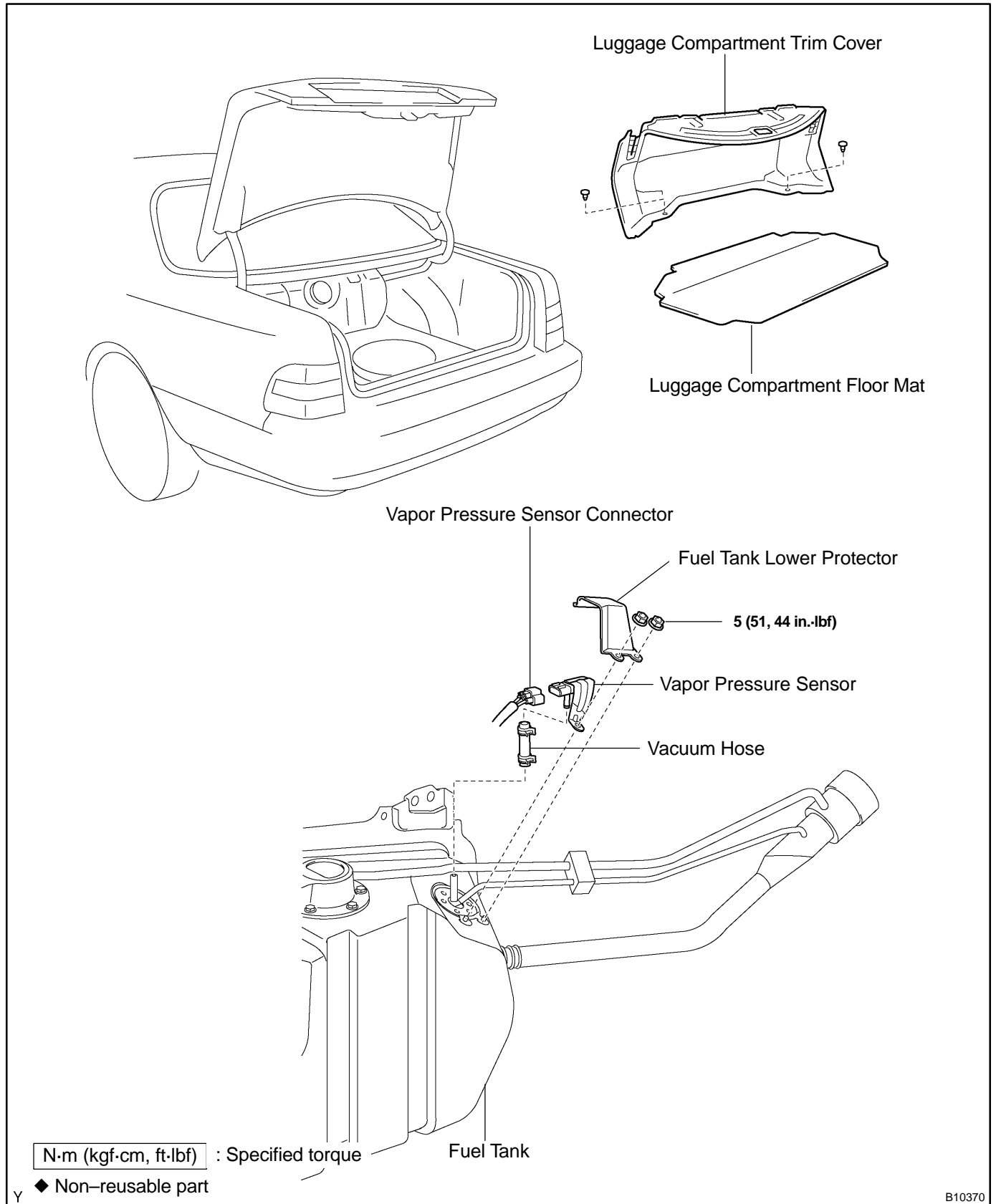

B10370

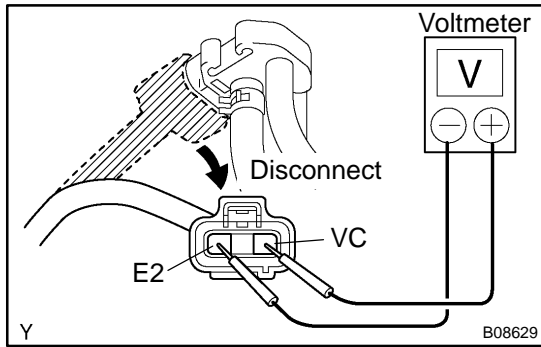

INSPECTION

1. INSPECT POWER SOURCE VOLTAGE OF VAPOR PRESSURE SENSOR

- Disconnect the vapor pressure sensor connector.
- Turn the ignition switch ON.
- Using a voltmeter, measure the voltage between connector terminals VC and E2 of the wiring harness side.
Voltage: 4.5 – 5.5 V
- Turn the ignition switch OFF.
- Reconnect the vapor pressure sensor connector.

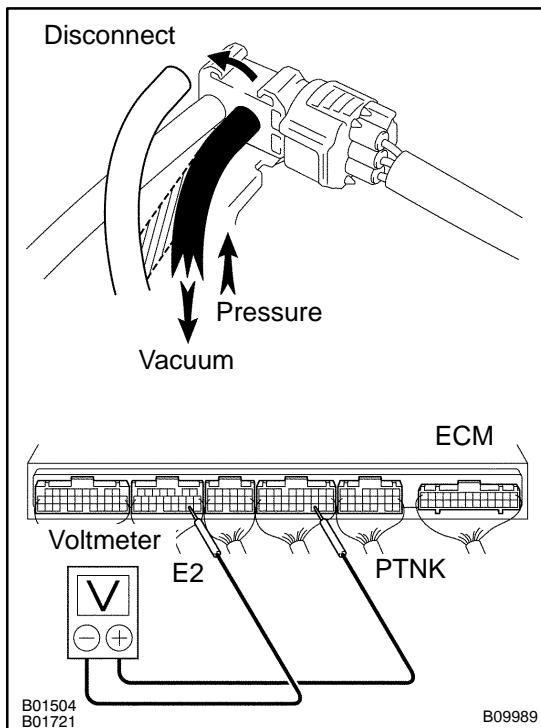

2. INSPECT POWER OUTPUT OF VAPOR PRESSURE SENSOR

- Turn the ignition switch ON.
- Disconnect the fuel hose from the vapor pressure sensor.
- Connect a voltmeter to terminals PTNK and E2 of the ECM, and measure the output voltage under the following conditions:
 - Apply vacuum (2.0 kPa (15 mmHg, 0.59 in.Hg)) to the vapor pressure sensor.
Voltage: 1.3 – 2.1 V
 - Release the vacuum from the vapor pressure sensor.
Voltage: 3.0 – 3.6 V
 - Apply pressure (1.5 kPa (15 gf/cm², 0.22 psi)) to the vapor pressure sensor.
Voltage: 4.2 – 4.8 V
- Turn the ignition switch OFF.
- Reconnect the fuel hose to the vapor pressure sensor.

KNOCK SENSOR COMPONENTS

SF06-02

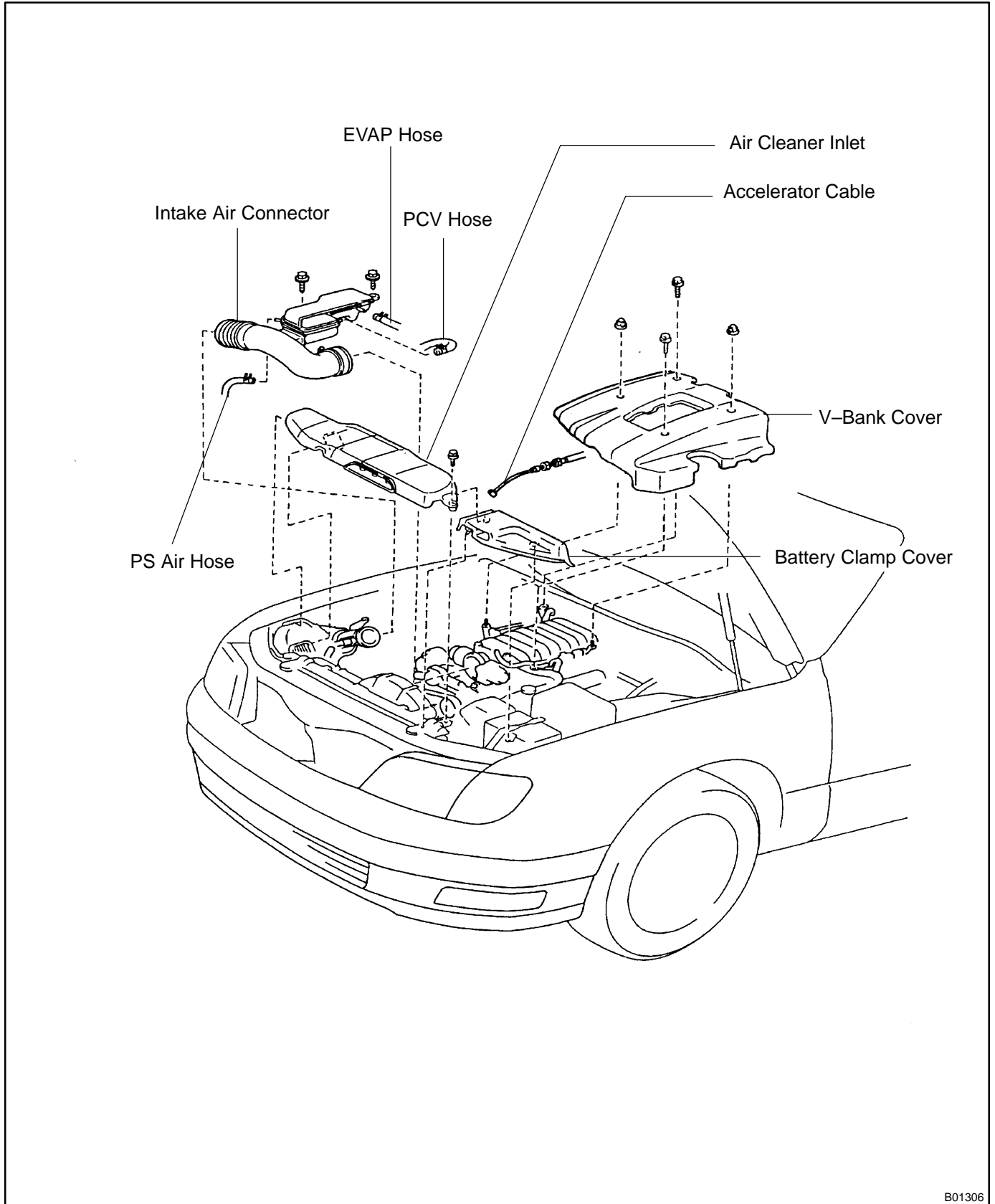

B01306

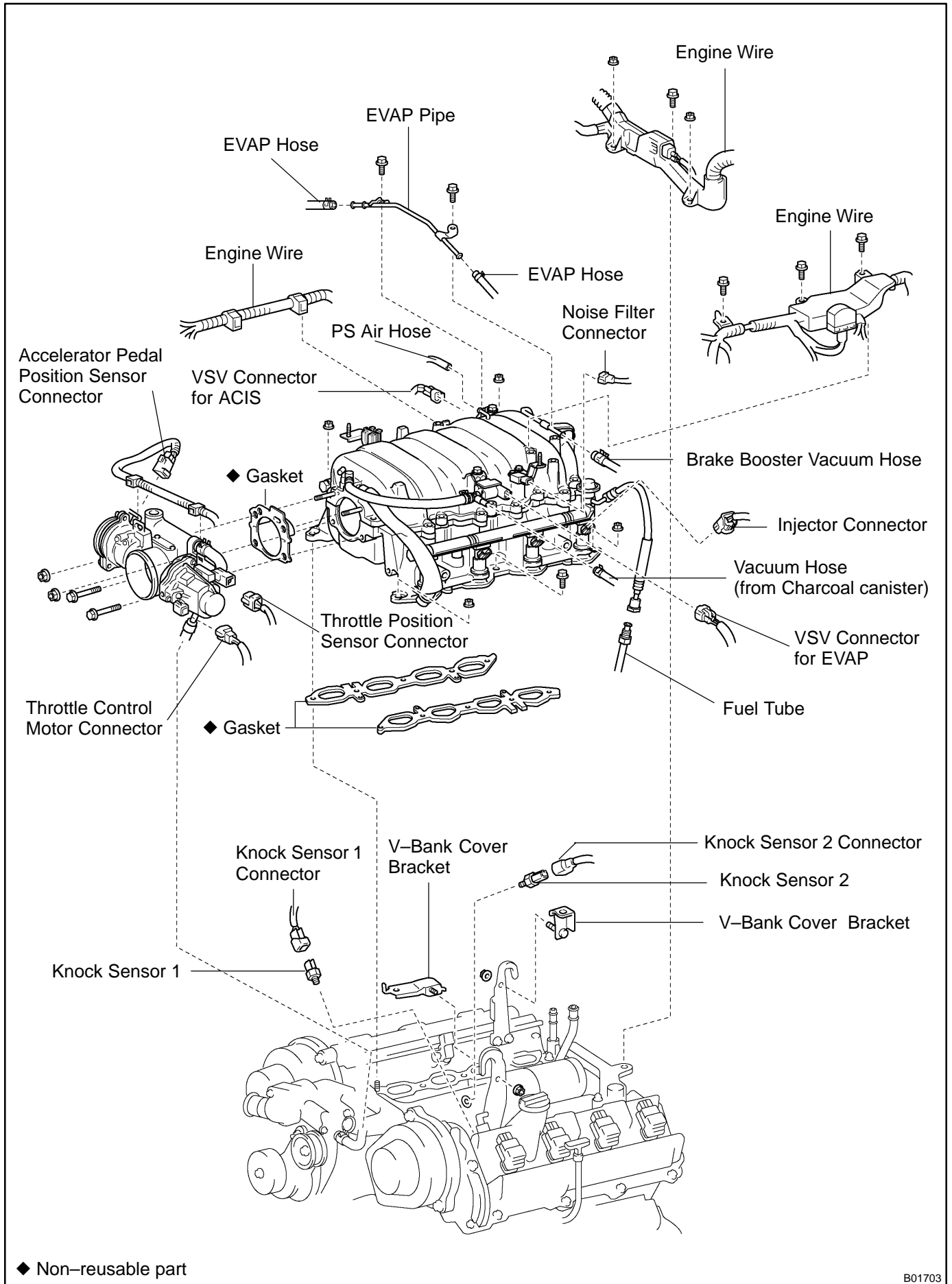

INSPECTION

1. REMOVE V-BANK COVER
2. REMOVE BATTERY CLAMP COVER, AIR CLEANER INLET AND INTAKE AIR CONNECTOR
3. DISCONNECT THROTTLE BODY (See page SF-59)
4. REMOVE INTAKE MANIFOLD ASSEMBLY (See page EM-34)
5. REMOVE KNOCK SENSOR
 - (a) Disconnect the knock sensor connectors.
 - (b) Using SST, remove the 2 knock sensors.
SST 09816-30010

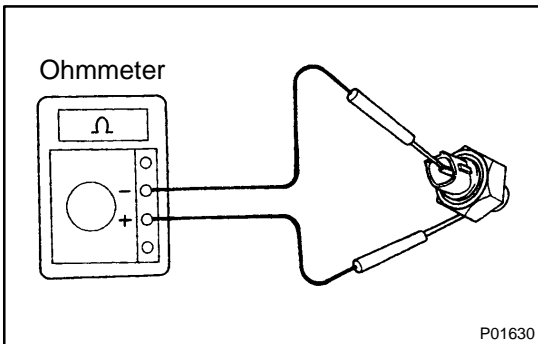
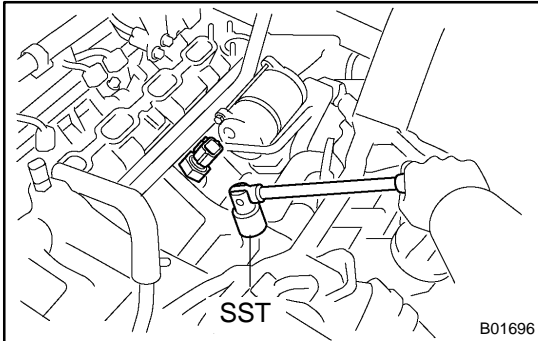

6. INSPECT KNOCK SENSOR

Using an ohmmeter, check that there is no continuity between the terminal and body.
If there is continuity, replace the sensor.

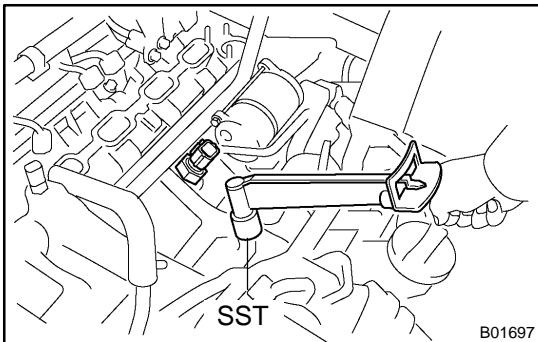

7. REINSTALL KNOCK SENSOR

- (a) Using SST, install the 2 knock sensors.
SST 09816-30010
Torque: 44 N·m (450 kgf·cm, 33 ft·lbf)
- (b) Connect the knock sensor connectors.
8. REINSTALL INTAKE MANIFOLD ASSEMBLY (See page EM-58)
9. RECONNECT THROTTLE BODY (See page SF-61)
10. CHECK FOR FUEL LEAKS (See page SF-1)
11. REINSTALL INTAKE AIR CONNECTOR, AIR CLEANER INLET AND BATTERY CLAMP COVER
12. REINSTALL V-BANK COVER

HEATED OXYGEN SENSOR COMPONENTS

SF038-02

Bank 1 Sensor 1

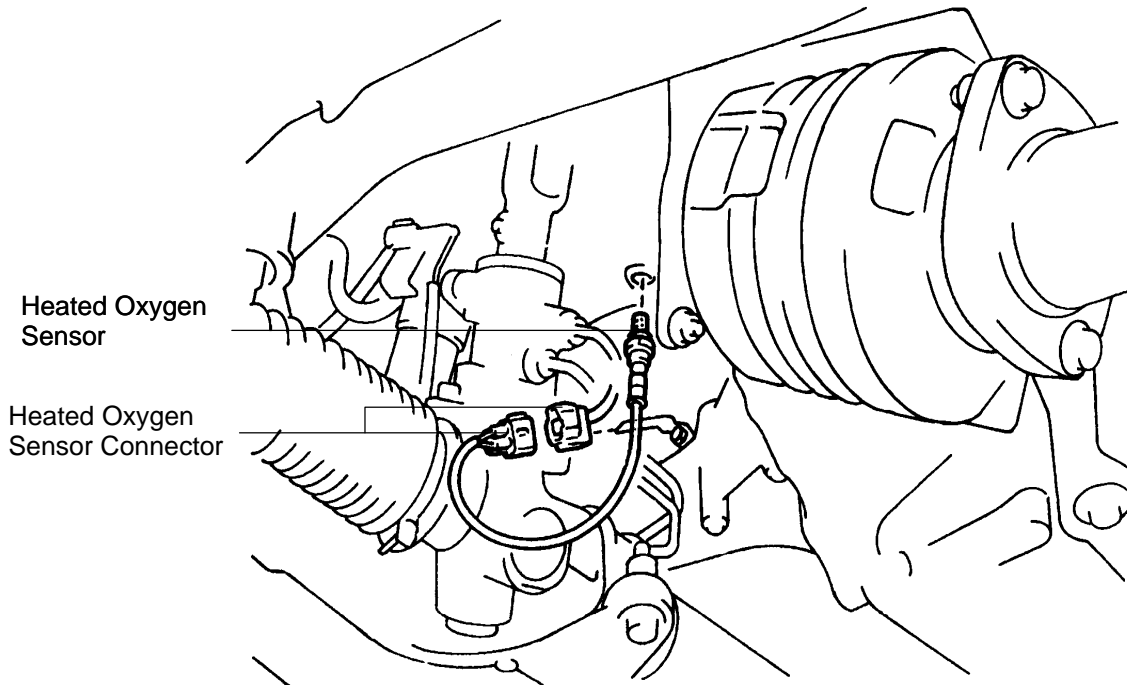

Bank 2 Sensor 1

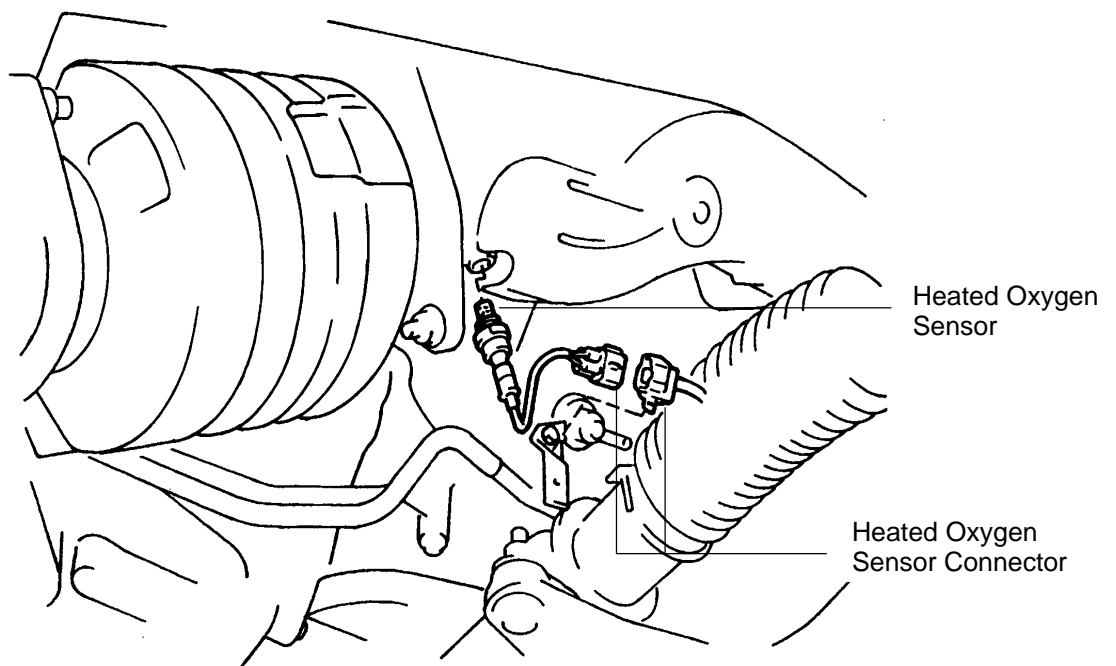

B01698

Bank 1 Sensor 2

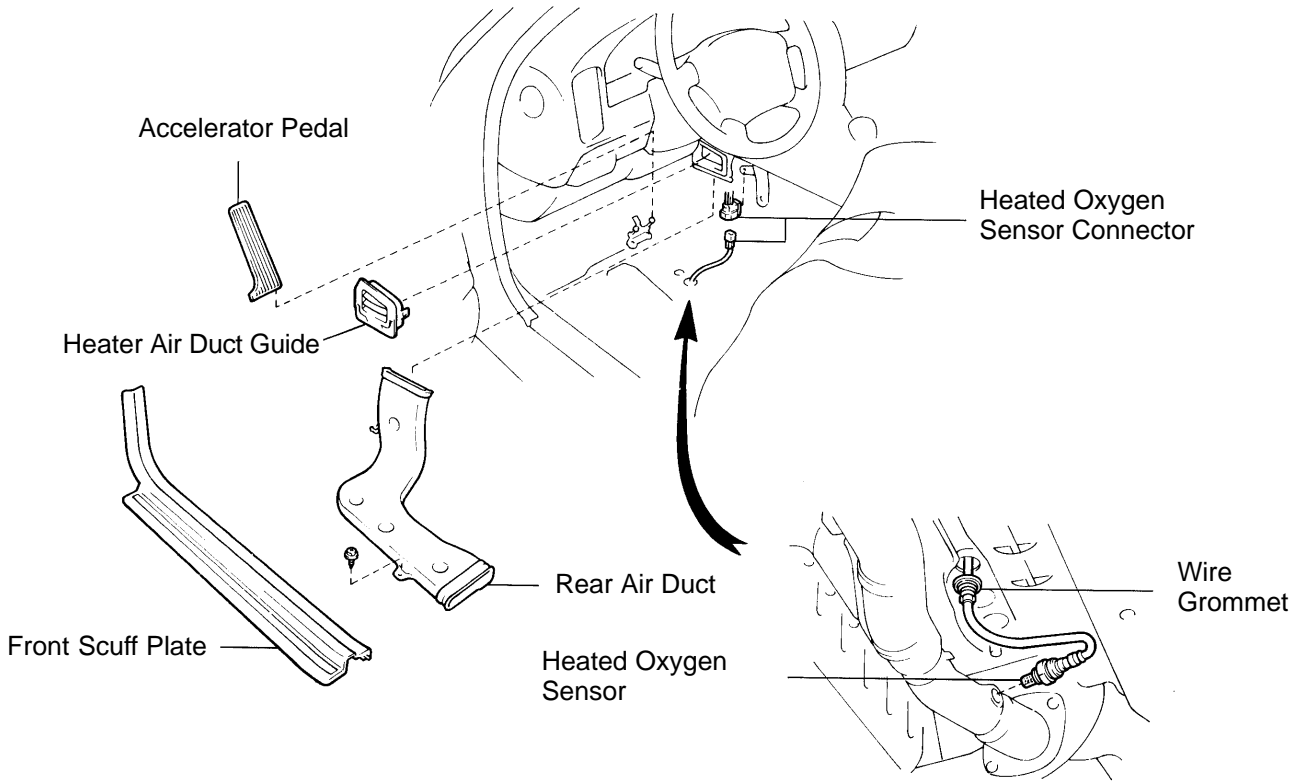

Bank 2 Sensor 2

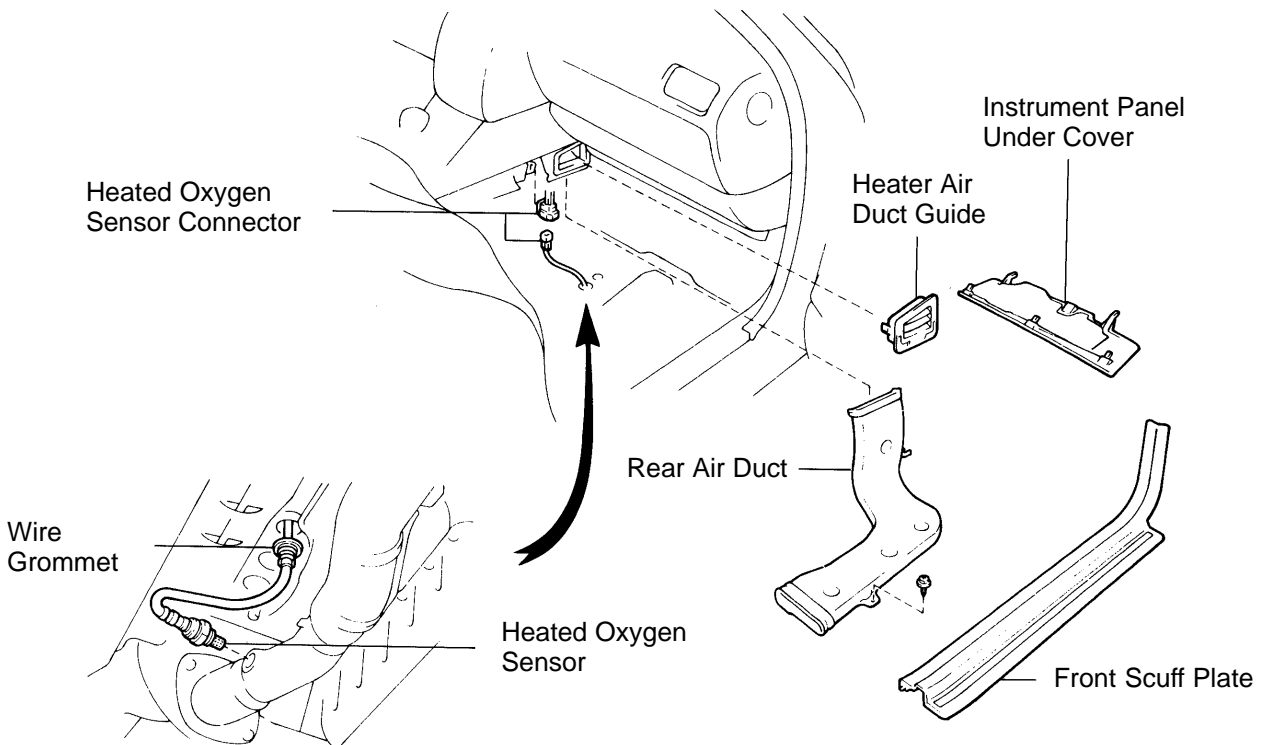

P23624
P23625

Z15685

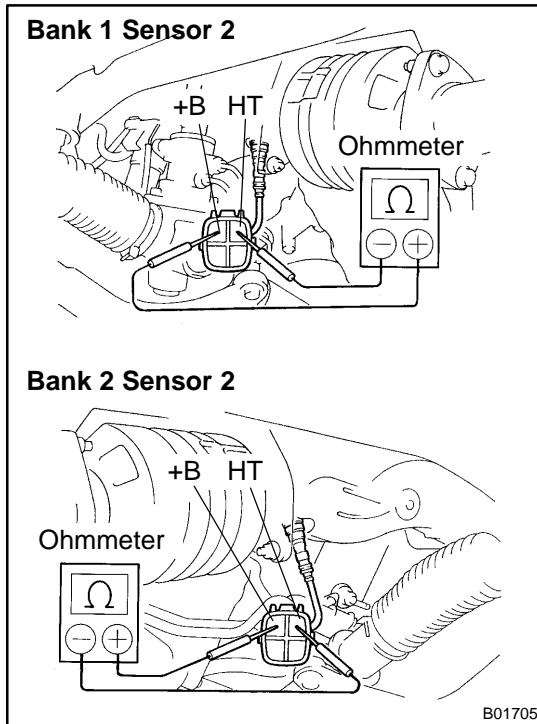

INSPECTION

1. INSPECT HEATER RESISTANCE OF HEATED OXYGEN SENSORS (BANK 1, 2 SENSOR 1)

- Disconnect the oxygen sensor connectors.
- Using an ohmmeter, measure the resistance between the terminals +B and HT.

Resistance:

20°C (68°F)	11 – 16 Ω
800°C (1,472°F)	23 – 32 Ω

If the resistance is not as specified, replace the sensor.

- Reconnect the oxygen sensor connectors.

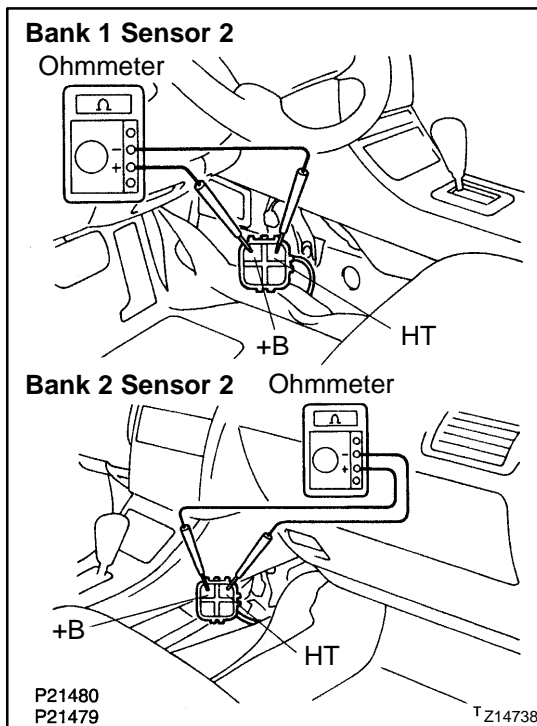

2. INSPECT HEATER RESISTANCE OF HEATED OXYGEN SENSORS (BANK 1, 2 SENSOR 2)

- Disconnect the oxygen sensor connectors.
- Using an ohmmeter, measure the resistance between the terminals +B and HT.

Resistance:

20°C (68°F)	11 – 16 Ω
800°C (1,472°F)	23 – 32 Ω

If the resistance is not as specified, replace the sensor.

- Reconnect the oxygen sensor connectors.

3. INSPECT OPERATION OF HEATED OXYGEN SENSORS (See page DI-51)