

The plug terminal numbering is based on looking at the plug face where it mates with the ECU. It starts at the top left corner, top is defined as the plug locking tab.

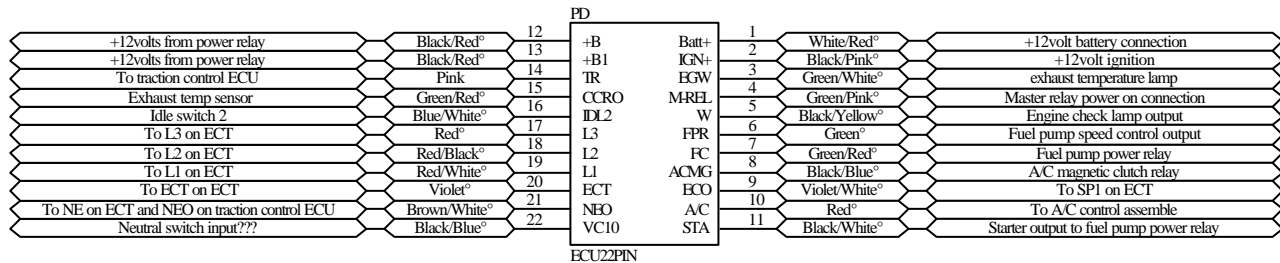
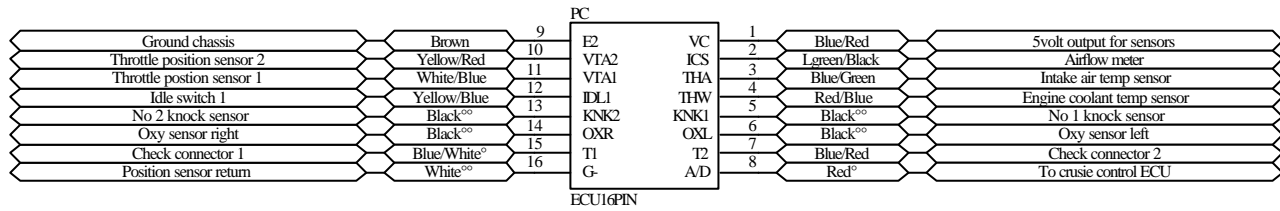
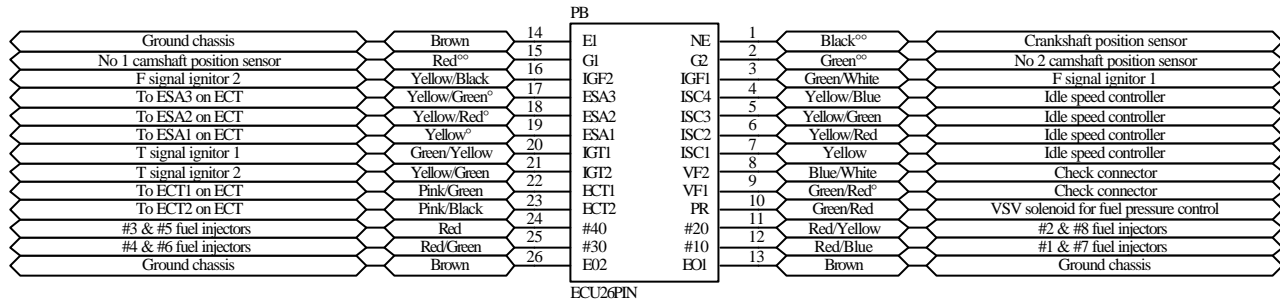
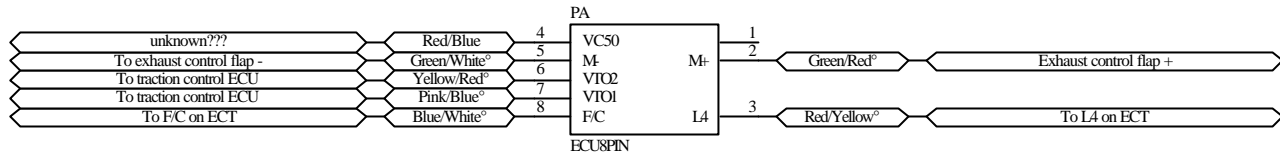
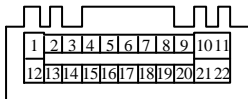
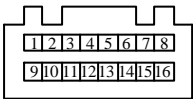
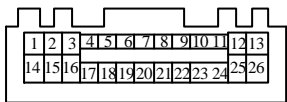
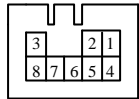

Colours are main colour followed by the stripe colour. eg Black/Red is a black wire with a red stripe

° - represents a pink band around the wire  
Wire has a PVC sheath which is thinner than normal sheath. Therefore wire is 16 gauge and is larger than the normal 20 gauge it would appear.

°° - represents a silver band around the wire  
This means wire normally has a shield around which is grounded.

Title			
Crown ECU wiring diagram			
Size	Number	Revision	
A4	1	1	
Date:	2-Mar-2004	Sheet of	1 of 2
File:	C:\Crown\CROWN\ECU.DDB	Drawn By:	Russell Koehne