

Idle Speed Control (ISC) System

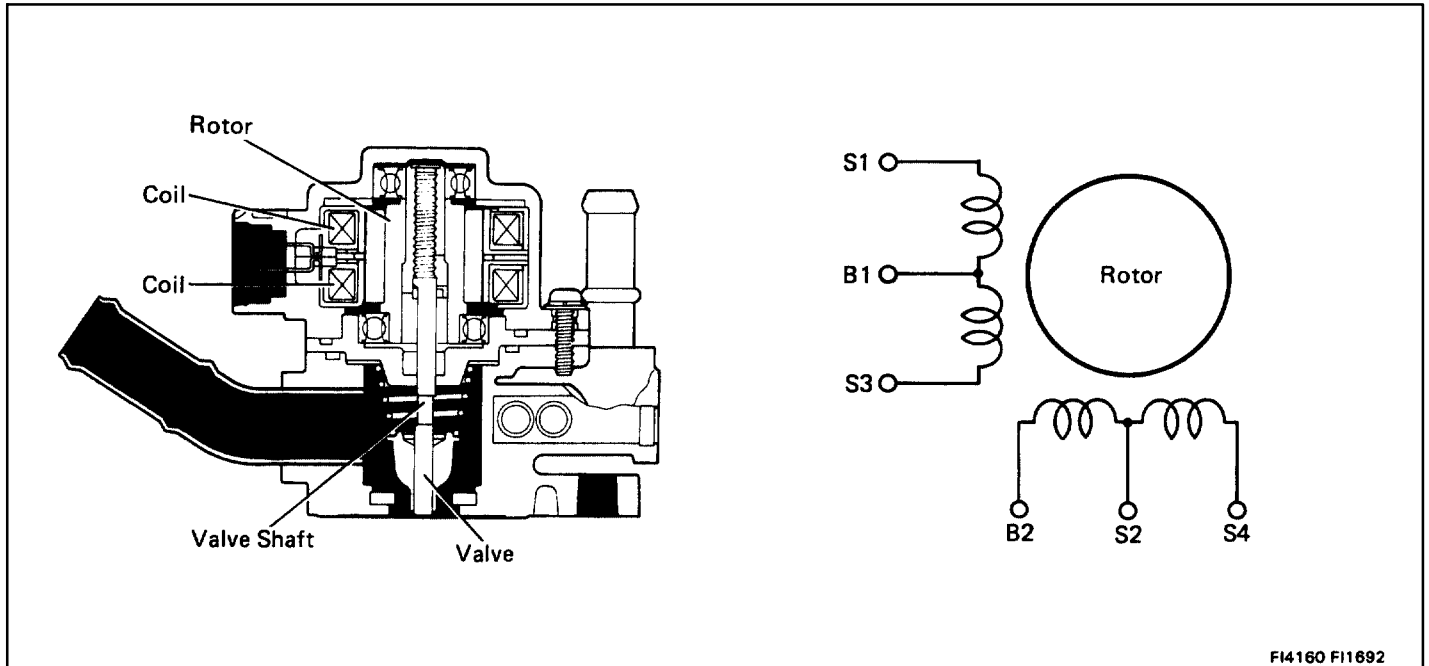

FI4160 FI1692

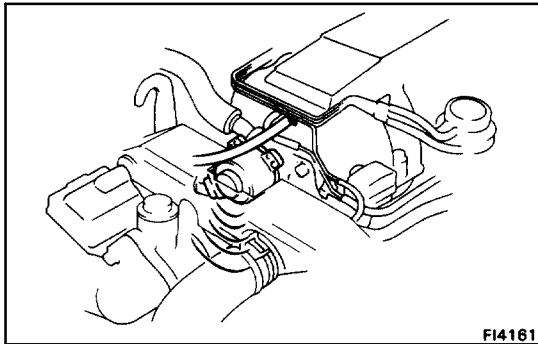

FI4161

ON-VEHICLE INSPECTION CHECK SOUND OF ISC VALVE OPERATION

Immediately after engine warmup, check that the valve makes a clicking sound.

REMOVAL OF ISC VALVE

1. DRAIN COOLANT
(See step 3 on pages CO-5, 6)
2. REMOVE UPPER HIGH-TENSION CORD COVER AND TWO ENGINE WIRE COVERS
3. REMOVE TWO NO.3 TIMING BELT COVERS AND LOWER HIGH-TENSION CORD COVER
4. DISCONNECT FOLLOWING HOSES FROM AIR INTAKE CHAMBER:
 - (a) PS idle-up hose
 - (b) VSV vacuum hose for FPU

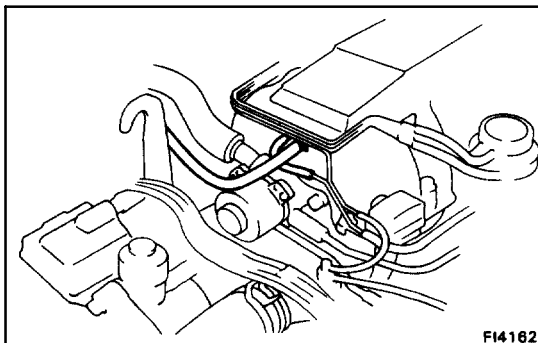

FI4162

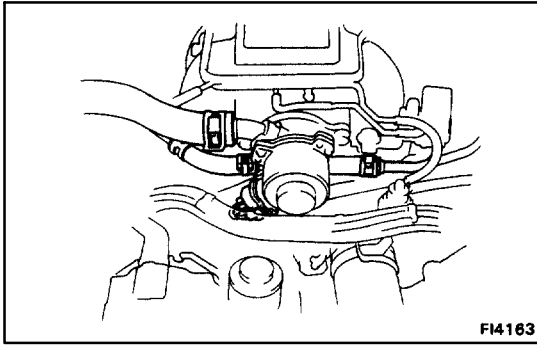

5. **REMOVE ISC AIR HOSE**
6. **DISCONNECT FOLLOWING HOSES FROM ISC VALVE:**
 - (a) No.4 water by-pass pipe
 - (b) No.5 water by-pass pipe
7. **DISCONNECT ISC VALVE CONNECTOR**

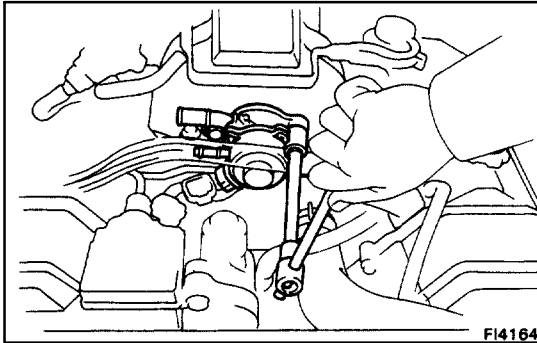

8. **REMOVE ISC VALVE**
 - (a) Remove the two nuts, and remove the ISC valve and gasket.
 - (b) Disconnect the water hose from the water inlet housing.

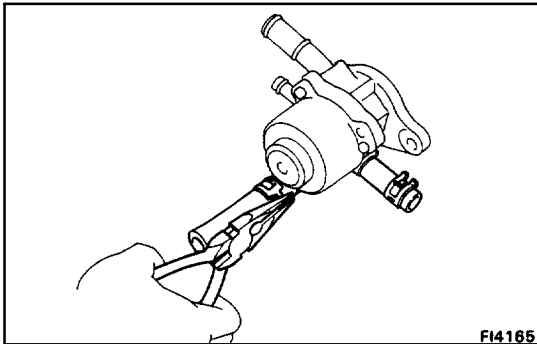

9. **DISCONNECT TWO WATER HOSES**
Disconnect the two water hoses from the ISC valve.

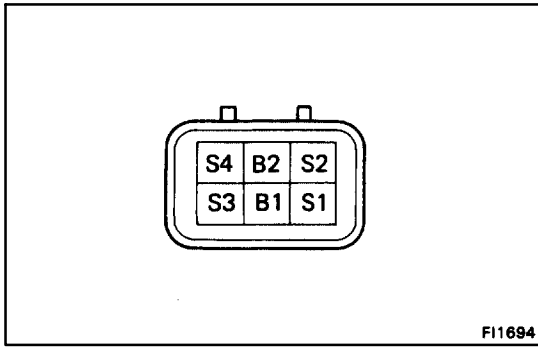

INSPECTION OF ISC VALVE

1. CHECK ISC VALVE OPERATION

Using an ohmmeter, measure the resistance between each pair of terminals.

Resistance: B1-S1 (S3) 10-30 Ω

B2-S2 (S4) 10-30 Ω

If the resistance is not as specified, replace the ISC valve.

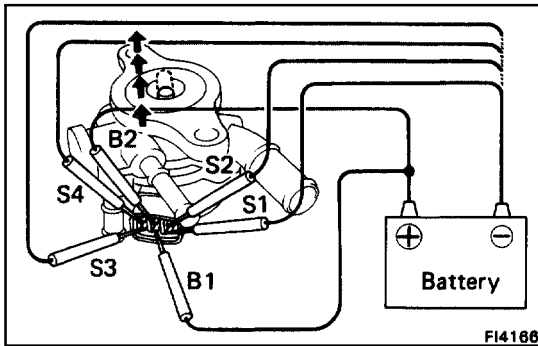

2. CHECK ISC VALVE OPERATION

(a) Connect the battery positive terminal to terminal B1 and B2, and connect the negative terminal to terminals S1 S2 S3 S4 in that order, and check that the valve moves in the closed direction.

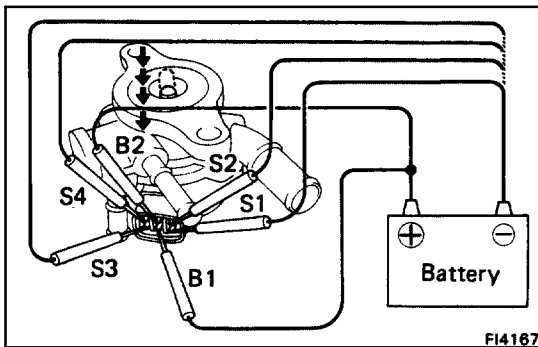

(b) Connect the battery positive terminal to terminals B1 and B2, and connect the negative terminal to terminals S4 S3 S2 S1 in that order, and check that the valve moves in the open direction.

If the ISC valve does not operate as specified, replace ISC valve.

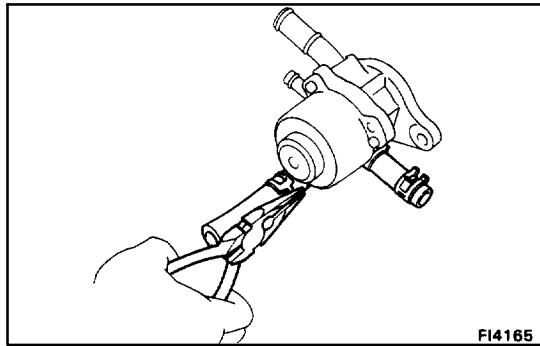

FI4165

INSTALLATION OF ISC VALVE

1. INSTALL TWO WATER HOSES

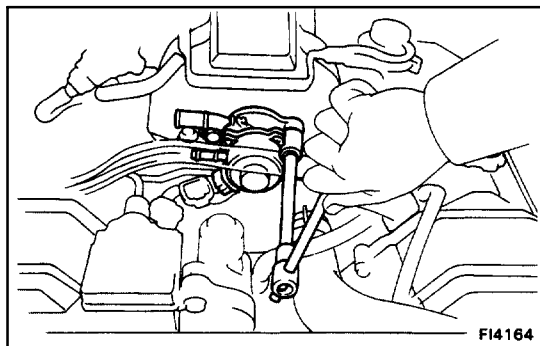

FI4164

2. INSTALL ISC VALVE

- (a) Install a new gasket to the air intake chamber.
- (b) Connect the water hose to the water inlet housing.
- (c) Install the ISC valve with two nuts.

Torque: 185 kg-cm (13 ft-lb, 18 N·m)

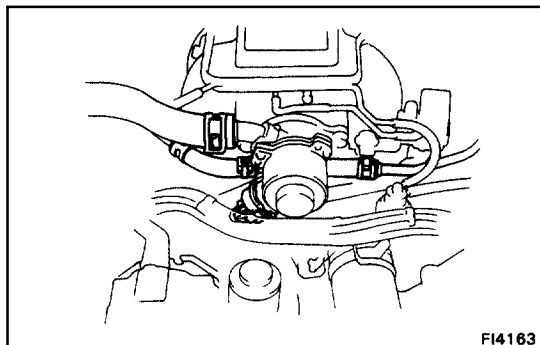

FI4163

3. CONNECT ISC VALVE CONNECTOR

4. CONNECT FOLLOWING HOSES TO ISC VALVE:

- (a) No.5 water by-pass pipe
- (b) No.4 water by-pass pipe

5. CONNECT ISC AIR HOSE

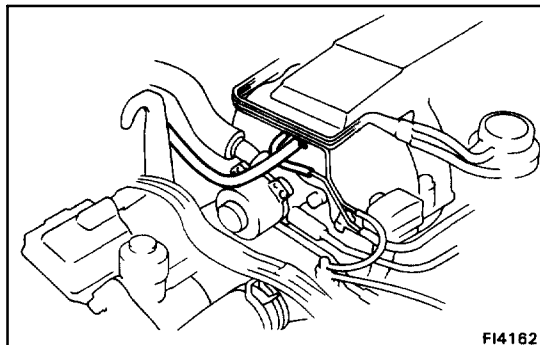

FI4162

6. CONNECT FOLLOWING HOSES TO AIR INTAKE CHAMBER:

- (a) VSV vacuum hose for FPU
- (b) PS idle-up hose

7. INSTALL LOWER HIGH-TENSION CORD COVER AND TWO NO.3 TIMING BELT COVERS

8. INSTALL TWO ENGINE WIRE COVERS AND UPPER HIGHTENSION CORD COVER

9. FILL WITH COOLANT

(See step 3 on pages [CO-5](#), [6](#))

10. CHECK FOR COOLANT LEAKAGE

Start the engine and check for coolant leakage.

11. CHECK COOLANT LEVEL

(See step 1 on page [CO-5](#))