

DTC	P1349	VVT System Malfunction (Bank 1)
------------	--------------	--

DTC	P1354	VVT System Malfunction (Bank 2)
------------	--------------	--

CIRCUIT DESCRIPTION

VVT system controls the intake valve timing to proper timing in response to driving condition. ECM controls OCV (Oil Control Valve) to make the intake valve timing properly, and, oil pressure controlled with OCV is supplied to the VVT controller, and then, VVT controller changes relative position between the camshaft and the crankshaft.

DTC No.	DTC Detecting Condition	Trouble Area
P1349 P1354	Condition (a) or (b) continues for after the engine is warmed up and engine speed at 400 ~ 4,000 rpm : (a) Valve timing does not change from of current valve timing (b) Current valve timing is fixed.	<ul style="list-style-type: none"> • Valve timing • Oil control valve • VVT controller assembly • ECM

WIRING DIAGRAM

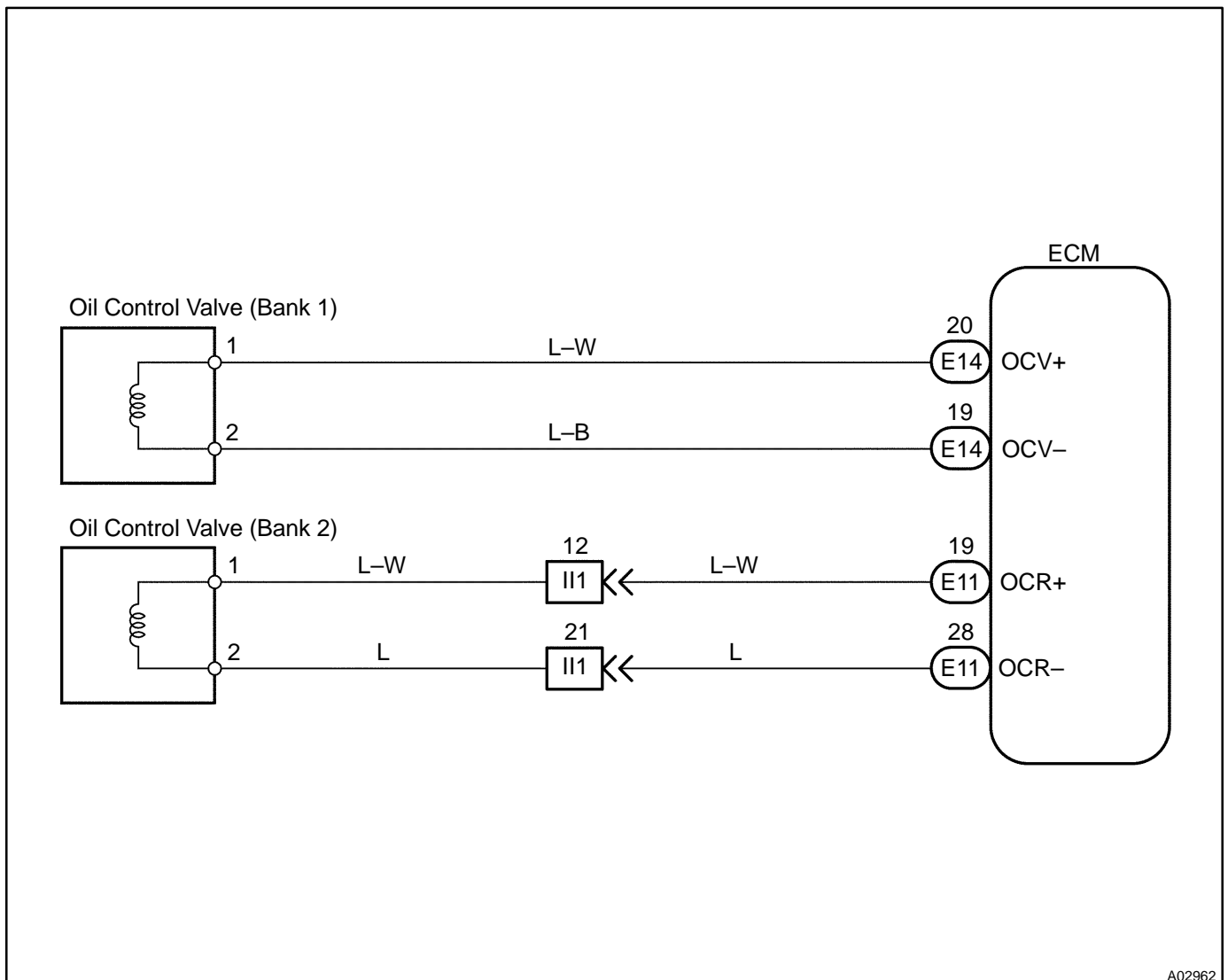

INSPECTION PROCEDURE

HINT:

- If DTC P1349 is displayed, check left bank VVT system circuit.
- If DTC P1354 is displayed, check right bank VVT system circuit.
- Read freeze frame data using LEXUS hand-held tester or OBD II scan tool. Because freeze frame records the engine conditions when the malfunction is detected, when troubleshooting it is useful for determining whether the vehicle was running or stopped, the engine warmed up or not, the air-fuel ratio lean or rich, etc. at the time of the malfunction.

LEXUS hand-held tester

1	Check valve timing (See page EM-15).
----------	---

NG	Repair valve timing.
-----------	-----------------------------

OK

2	Check operation of OCV.
----------	--------------------------------

PREPARATION:

- (a) Start the engine and warmed it up.
- (b) Connect the LEXUS hand-held tester and select VVT from ACTIVE TEST menu.

CHECK:

Check the engine speed when operate the OCV by the LEXUS hand-held tester.

OK:

- OCV is OFF:**
- Normal engine speed**
- OCV is ON:**
- Rough idle or engine stall**

OK	VVT system is OK.*
-----------	---------------------------

*: DTC P1349 and P1354 are also output after the foreign object is caught in some part of the system in the engine oil and the system returns to normal in a short time. As ECM controls so that foreign objects are ejected, there is no problem about VVT. There is also no problem since the oil filter should get the foreign object in the engine oil.

NG

3 Check voltage between terminals OCV+ and OCV- of ECM connector.

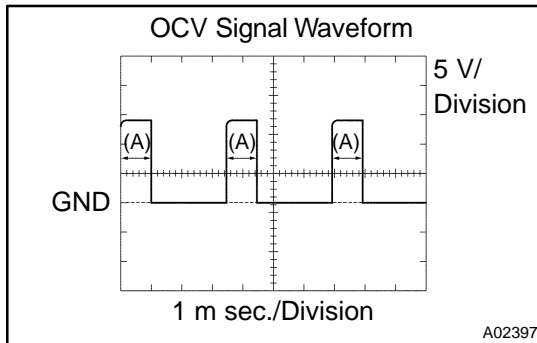

Reference: INSPECTION USING OSCILLOSCOPE

Turn the ignition switch ON, check waveform between terminals OCV+ and OCV- of the ECM connector.

HINT:

- The correct waveform is as shown.
- The waveform frequency (A) is lengthened as the engine speed becomes higher.

NG

Check and replace ECM (See page [IN-30](#)).

OK

4 Check VVT controller assembly.

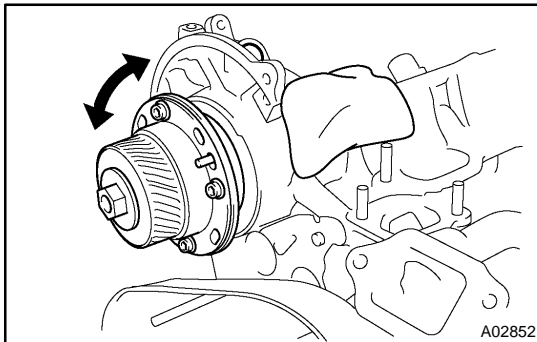

PREPARATION:

- Remove the timing belt (See page [EM-15](#)).
- Remove the cylinder head cover.
- Remove the oil control valve (See page [EM-33](#)).
- Drain oil into the VVT controller assembly (See page [EM-33](#)).

CHECK:

Check whether the oil into VVT controller assembly is drained or not.

OK:

The oil into VVT controller assembly is drained.

NG

Replace VVT controller assembly, and then go to step 5.

OK

5 Check oil control valve (See page [SF-51](#)).

NG

Replace oil control valve, and then go to step 6.

OK

6 Check blockage of oil control valve, oil check valve and oil pipe No.1.

NG Repair or replace.

OK

7 Check whether or not DTC P1349/P1354 is stored.

PREPARATION:

- (a) Clear the DTC (See page DI-3).
- (b) Perform simulation test.

CHECK:

Check whether or not DTC P1349/P1354 is stored (See page DI-3).

OK:

DTC P1349/P1354 is not stored

OK VVT system is OK.*

*: DTC P1349 and P1354 are also output after the foreign object is caught in some part of the system in the engine oil and the system returns to normal in a short time. As ECM controls so that foreign objects are ejected, there is no problem about VVT. There is also no problem since the oil filter should get the foreign object in the engine oil.

NG

Replace ECM

OBD II scan tool (excluding LEXUS hand-held tester)

1 Check valve timing (See page EM-15).

NG Repair valve timing.

OK

2	Check operation of OCV.
----------	--------------------------------

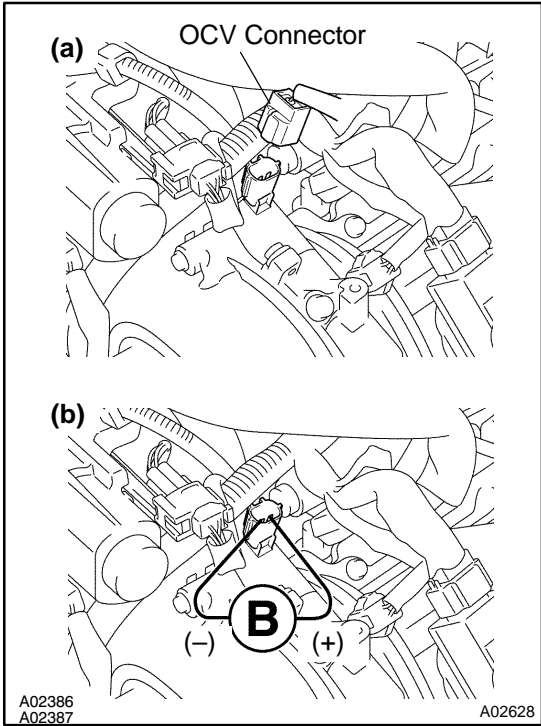

PREPARATION:

Start the engine.

CHECK:

- (a) Check the engine speed when disconnect the OCV connector.
- (b) Check the engine speed when apply battery positive voltage between terminals of OCV.

RESULT:

Result	Check (a)	Check (b)
1	Normal engine speed	Rough idle or engine stall
2	Except 1	

1

2
Go to step 4.

3 Check voltage between terminals OCV+ and OCV- of ECM connector.

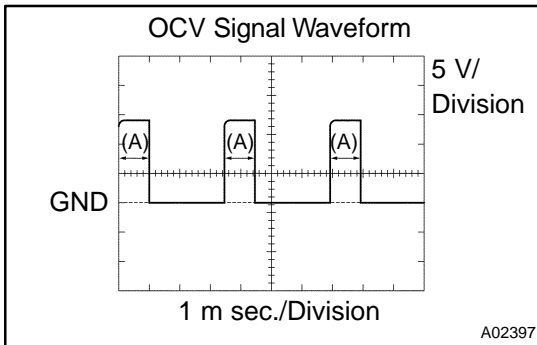

Reference: INSPECTION USING OSCILLOSCOPE

Turn the ignition switch ON, check waveform between terminals OCV+ and OCV- of the ECM connector.

HINT:

- The correct waveform is as shown.
- The waveform frequency (A) is lengthened as the engine speed becomes higher.

OK

VVT system is OK.*

*: DTC P1349 and P1354 are also output after the foreign object is caught in some part of the system in the engine oil and the system returns to normal in a short time. As ECM controls so that foreign objects are ejected, there is no problem about VVT. There is also no problem since the oil filter should get the foreign object in the engine oil.

NG

Check and replace ECM (See page [IN-30](#)).

4 Check VVT controller assembly.

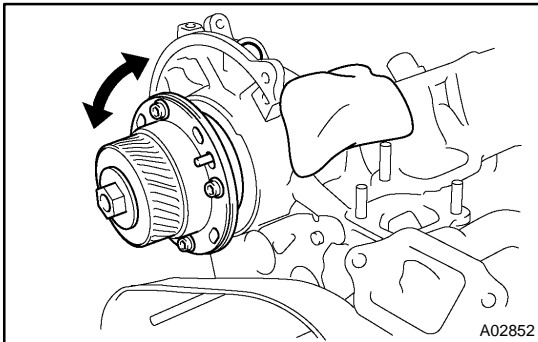

PREPARATION:

- Remove the timing belt (See page [EM-15](#)).
- Remove the cylinder head cover.
- Remove the oil control valve (See page [EM-33](#)).
- Drain oil into the VVT controller assembly (See page [EM-33](#)).

CHECK:

Check whether the oil into VVT controller assembly is drained or not.

OK:

The oil into VVT controller assembly is drained.

NG

Replace VVT controller assembly, and then go to step 5.

OK

5	Check oil control valve (See page SF-51).
----------	--

NG	Replace oil control valve, and then go to step 6.
-----------	--

OK

6	Check blockage of oil control valve, oil check valve and oil pipe No.1.
----------	--

NG	Repair or replace.
-----------	---------------------------

OK

7	Check whether or not DTC P1349/P1354 is stored.
----------	--

PREPARATION:

- (a) Clear the DTC (See page [DI-3](#)).
- (b) Perform simulation test.

CHECK:

Check whether or not DTC P1349/P1354 is stored (See page [DI-3](#)).

OK:

DTC P1349/P1354 is not stored

OK	VVT system is OK.*
-----------	---------------------------

*: DTC P1349 and P1354 are also output after the foreign object is caught in some part of the system in the engine oil and the system returns to normal in a short time. As ECM controls so that foreign objects are ejected, there is no problem about VVT. There is also no problem since the oil filter should get the foreign object in the engine oil.

NG

Replace ECM
