

INSPECTION

1. INSPECT TIMING BELT

NOTICE:

- Do not bend, twist or turn the timing belt inside out.
- Do not allow the timing belt to come into contact with oil, water or steam.
- Do not utilize timing belt tension when installing or removing the mount bolt of the camshaft timing pulley.

If there are any defects, as shown in the illustrations, check these points:

- (a) Premature parting
 - Check for proper installation.
 - Check the timing cover gasket for damage and proper installation.
- (b) If the belt teeth are cracked or damaged, check to see if either camshaft is locked.
- (c) If there is noticeable wear or cracks on the belt face, check to see if there are nicks on the side of the idler pulley lock and water pump.
- (d) If there is wear or damage on only one side of the belt, check the belt guide and the alignment of each pulley.
- (e) If there is noticeable wear on the belt teeth, check timing cover for damage and check gasket has been installed correctly and for foreign material on the pulley teeth.

If necessary, replace the timing belt.

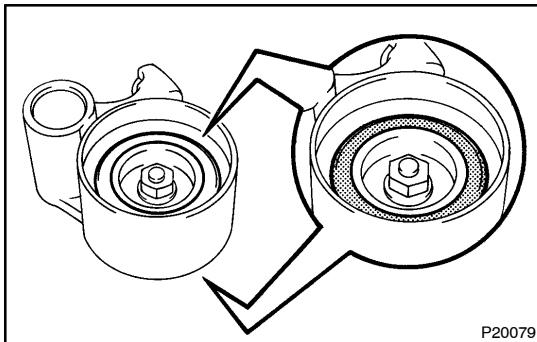

2. INSPECT IDLER PULLEYS

- (a) Visually check the seal portion of the idler pulley for oil leakage.

If leakage is found, replace the idler pulley.

- (b) Check that the idler pulley turns smoothly.

If necessary, replace the idler pulley.

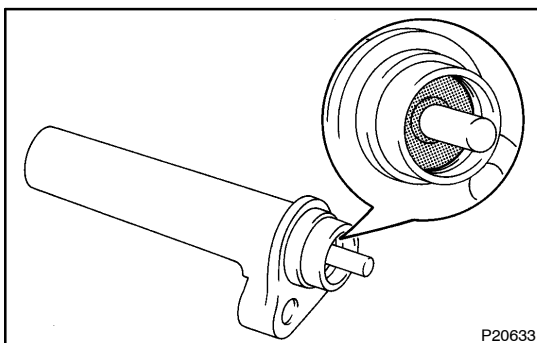

3. INSPECT TIMING BELT TENSIONER

- (a) Visually check the seal portion of the tensioner for oil leakage.

HINT:

If there is only the faintest trace of oil on the seal on the push rod side, the tensioner is all right.

If leakage is found, replace the tensioner.

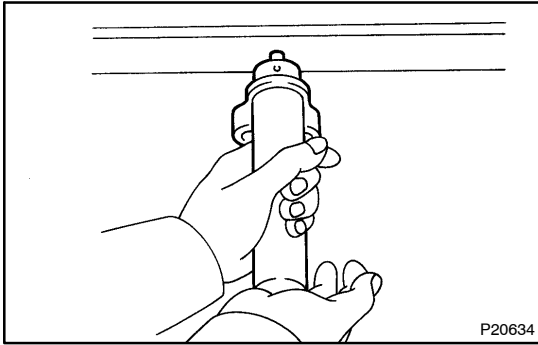

- (b) Hold the tensioner with both hands and push the push rod strongly as shown to check that it doesn't move. If the push rod moves, replace the tensioner.

NOTICE:

Never hold the tensioner push rod facing downward.

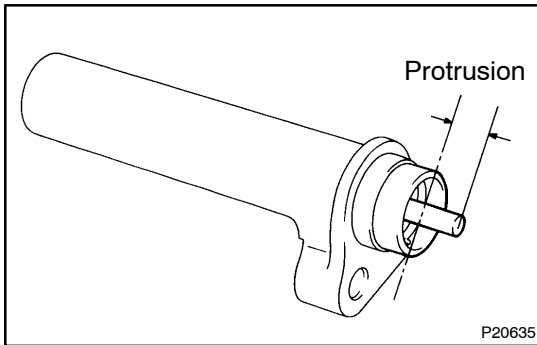

- (c) Measure the protrusion of the push rod from the housing end.

Protrusion:

10.5 – 11.5 mm (0.413 – 0.453 in.)

If the protrusion is not as specified, replace the tensioner.

4. INSPECT WATER PUMP

(See page [CO-10](#))