

DESCRIPTION

This engine utilizes a pressurized, forced circulation cooling system which includes a thermostat equipped with a bypass valve mounted on the inlet side.

The cooling system is composed of the water jacket (inside the cylinder block and cylinder head), radiator, water pump, thermostat, cooling fan, hoses and other components.

OPERATION

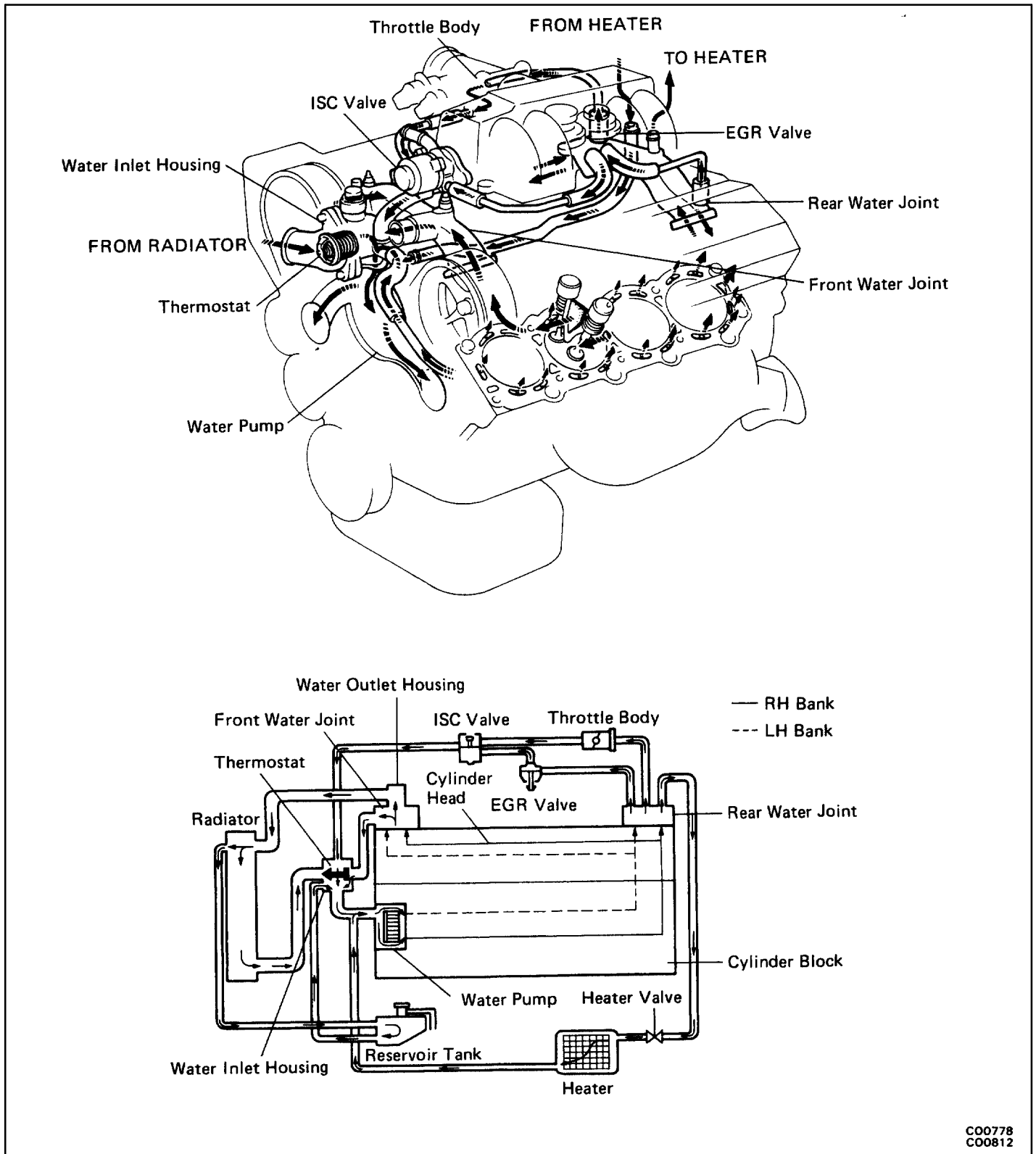

Coolant which is heated in the water jacket is pumped to the radiator, through which a cooling fan blows air to cool the coolant as it passes through. Coolant which has been cooled is then sent back to the engine by the water pump, where it cools the engine.

The water jacket is a network of channels in the shell of the cylinder block and cylinder head through which coolant passes. It is designed to provide adequate cooling of the cylinders and combustion chambers which become hottest during engine operation.

RADIATOR

The radiator performs the function of cooling the coolant which has passed through the water jacket and become hot, and is mounted in the front of the vehicle. The radiator consists of an upper tank and lower tank, and a core which connects the two tanks.

The upper tank contains the inlet for coolant from the water jacket and the filler inlet. It also has a hose attached through which excess coolant or steam can flow. The lower tank contains the outlet for coolant and the drain cock.

The core contains many tubes through which coolant flows from the upper tank to the lower tank as well as cooling fins which radiate heat away from the coolant in the tubes. The air pulled through the radiator by the cooling fan, as well as the wind generated by the vehicle's travel, passes through the radiator, cooling it. Models with automatic transmission include an automatic transmission fluid cooler built into the lower tank of the radiator. A cooling fan is mounted behind radiator to assist the flow of air through the radiator. When the coolant temperature is low, the fan operates slowly to help the engine warm up, and when the coolant temperature becomes high, the fan speed is increased to provide the air flow required for cooling.

RESERVOIR TANK CAP

The radiator cap is a pressure type cap which seals the radiator, resulting in pressurization of the radiator as the coolant expands. The pressurization prevents the coolant from boiling even when the coolant temperature exceeds 100°C.

A relief valve (pressurization valve) and a vacuum valve (negative pressure valve) are built into the radiator cap. The relief valve opens and lets steam es-

cape through the overflow pipe when the pressure generated inside the cooling system exceeds the limit (coolant temperature: 110–120°C, 230–248°F, pressure; 0.3–1.0 kg/cm², 4.3–14.2 psi, 29.4–98.1 kPa).

The vacuum valve opens to alleviate the vacuum which develops in the cooling system after the engine is stopped and the coolant temperature drops.

RESERVOIR TANK

The purpose of the reservoir tank is to catch coolant overflow created by volumetric expansion when the coolant temperature increases. The cap of the reservoir tank is a pressure type cap which prevents deterioration of the LLC (Long Life Coolant) caused by contact with atmospheric air, increases vaporization performance and reduces loss of coolant volume.

WATER PUMP

The water pump is mounted on the front of the cylinder block and driven by the reverse side of the timing belt.

THERMOSTAT

The thermostat has a wax type bypass valve and is mounted in the water inlet housing.

The thermostat begins to open at the temperature of 82°C (180°F).

When the coolant temperature is low, the valve closes to prevent coolant flow to the radiator, thus permitting the engine to warm up rapidly. When the bypass valve opens the bypass circuit, the engine coolant continues to circulate inside the engine, quickly and uniformly warming up to the appropriate temperature.

When the coolant temperature is high, the valve opens and coolant flows to the radiator where it is cooled. When the wax inside the thermostat is heated, it expands and thus creates pressure which overpowers the force of the spring which keeps the valve closed. When the wax cools, its contraction causes the force of the spring to take effect once more, closing the valve.

ELECTRIC COOLING FAN

This vehicle is equipped with two electric cooling fans to help cool the radiator. When the air conditioner compressor is operating the fans operate slowly, and when the radiator temperature increases the fans operate rapidly to help cool the engine.