

OVERHAUL

HINT:

- The installation procedures are the removal procedures in reverse order. However, only installation procedures requiring additional information are included.
- Use the same procedures for the RH side and LH side.
- The procedures listed below are for the LH side.
- A bolt without a torque specification is shown in the standard bolt chart (see page 03-2).

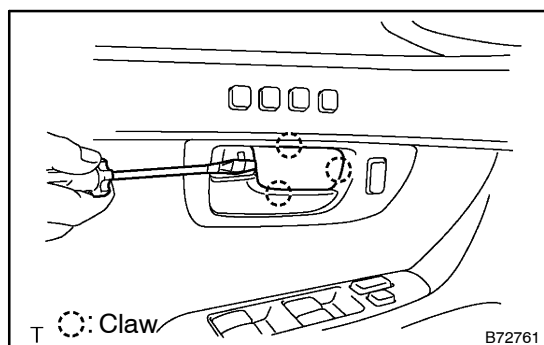

1. REMOVE DOOR INSIDE HANDLE BEZEL NO.2 LH

- Using a screwdriver, disengage the 3 claws and remove the bezel.

HINT:

Tape the screwdriver tip before use.

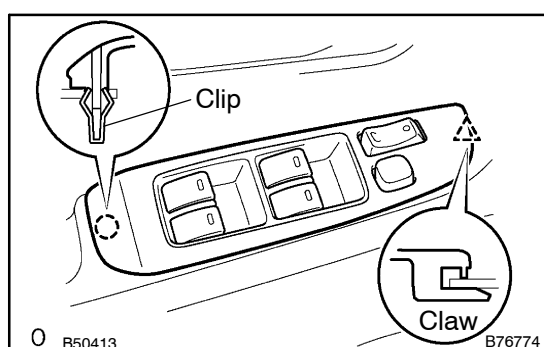

2. Driver side

REMOVE FRONT DOOR ARMREST BASE PANEL UPPER

- Using a screwdriver, pry the armrest panel assembly.

HINT:

Tape the screwdriver tip before use.

- Remove the 3 screws and power window regulator master switch.
- Remove the 2 screws and armrest base panel lower from the armrest base panel upper.

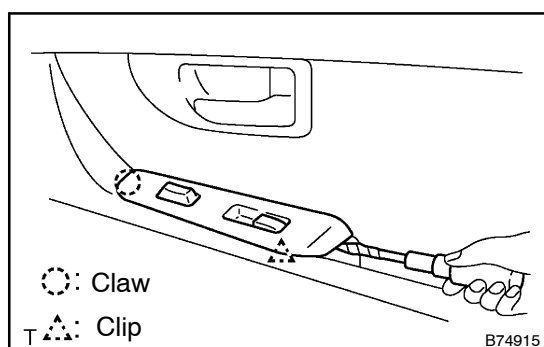

3. Passenger side

REMOVE FRONT DOOR ARMREST BASE PANEL UPPER

- Using a screwdriver, pry the armrest panel assembly.

HINT:

Tape the screwdriver tip before use.

- Using a screwdriver, disengage the 2 claws and remove the lock control switch from the armrest panel assembly.

HINT:

Tape the screwdriver tip before use.

- Using a screwdriver, disengage the 2 claws and remove the power window switch from the armrest assembly.

HINT:

Tape the screwdriver tip before use.

- Remove the 2 screws and armrest base panel lower from the armrest base panel upper.

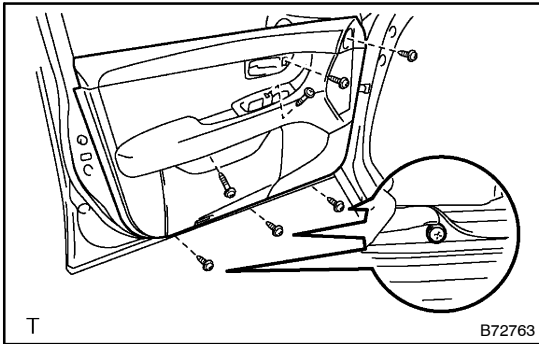

4. REMOVE FRONT DOOR TRIM BOARD SUB-ASSY LH

- (a) Remove the 7 screws as shown in the illustration.

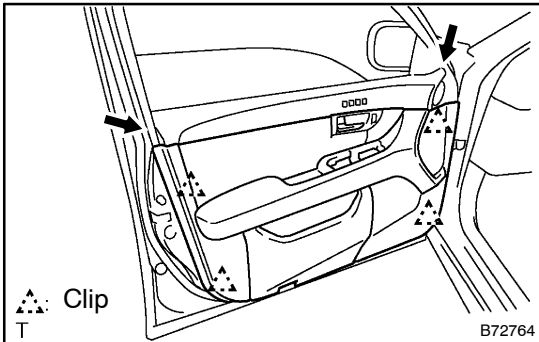

- (b) Using a screwdriver, disengage the 4 clips.

- (c) Remove the trim board upward.

HINT:

- In order to prevent the door panel from being damaged, use protective tape to cover the areas indicated by the arrow marks in the illustration.
- Tape the screwdriver tip before use.

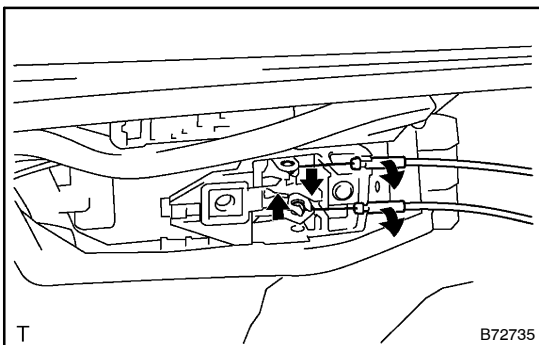

- (d) Disconnect the 2 cables from the inside handle.

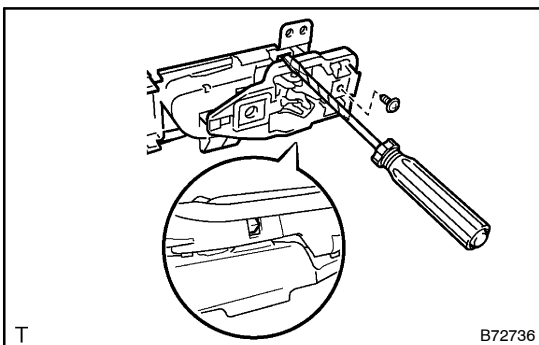

- (e) Remove the screw.

- (f) Using a screwdriver, disengage the 2 claws.

HINT:

Tape the screwdriver tip before use.

- (g) Remove the inside handle.

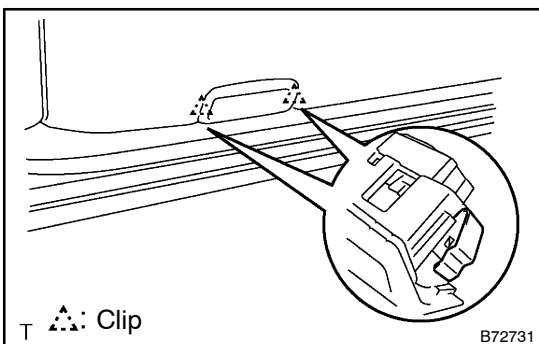

- (h) Using a screwdriver, disengage the 2 clips and remove the courtesy light.

- (i) Remove the 2 screws and seat memory switch.

- (j) Remove the 3 screws and vent seal.

- (k) Remove the 2 screws and door pocket.

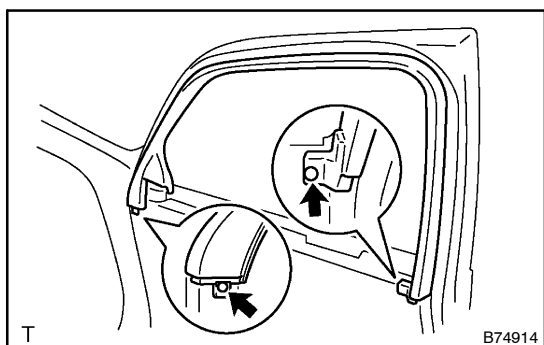
**5. REMOVE DOOR FRAME GARNISH LH**

- (a) Using a clip remover, disengage the 2 clips and remove the garnish.

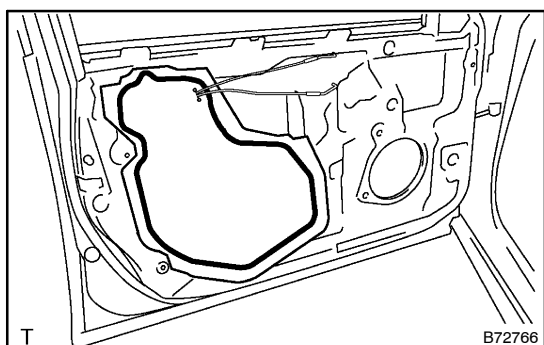
**6. REMOVE FRONT DOOR SERVICE HOLE COVER LH**

- (a) Remove the 2 screws and door electrical key oscillator.
 (b) Remove the service hole cover.

NOTICE:

Remove the remaining tape on the door side.

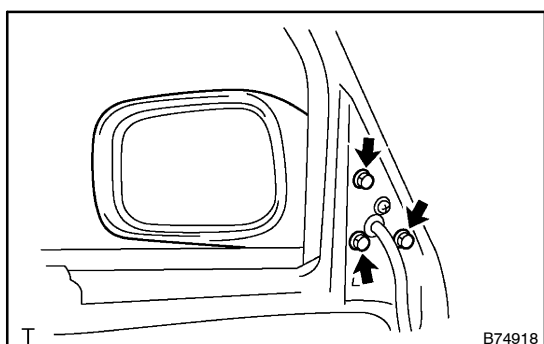
**7. REMOVE OUTER REAR VIEW MIRROR ASSY LH**

- (a) Disconnect the connector.
 (b) Remove the 3 bolts and mirror.

NOTICE:

Be careful when removing the bolts as the mirror may fall and become damaged.

8. REMOVE FRONT DOOR ECU

- (a) Disconnect the connector.
 (b) Remove the 2 screws and ECU.

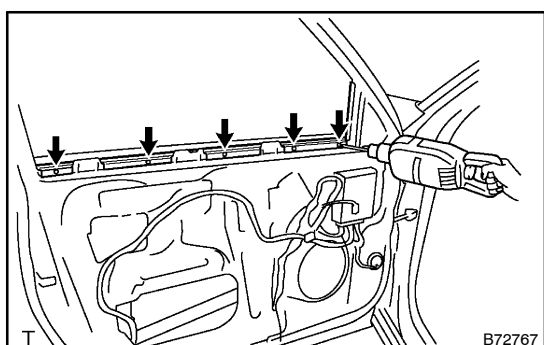
9. REMOVE FRONT NO.1 SPEAKER ASSY (See page 67-18)**10. REMOVE FRONT DOOR BELT MOULDING ASSY LH (See page 76-25)****11. REMOVE FRONT DOOR WINDOW FRAME MOULDING REAR LH (See page 76-27)****12. REMOVE FRONT DOOR WINDOW FRAME MOULDING FRONT LH (See page 76-27)****13. REMOVE FRONT DOOR GLASS RUN LH**

- (a) Using a drill of less than \varnothing 4 mm (0.16 in.), drill out the heads of the 5 rivets and remove the glass run.

NOTICE:

- Be sure to gently place the drill perpendicular to the rivet to prevent the rivet hole and the drill itself from being damaged.
 - Be careful as the cut rivet will become very hot.
- (b) Even if the flange is taken off, continue drilling and push out the remaining fragments using the drill.

- (c) Using a vacuum cleaner, remove the drilled rivets and dust from the inside of the door.

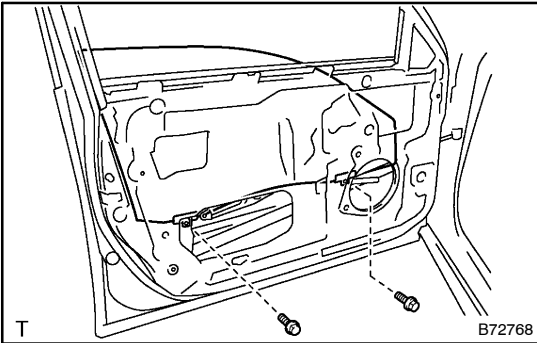

14. REMOVE FRONT DOOR GLASS SUB-ASSY LH

HINT:

Insert a shop rag inside the door panel to prevent the glass from being scratched.

- (a) Move the door glass until the bolts appear in the service holes.
 (b) Remove the 2 bolts holding the door glass to the window regulator.

NOTICE:

Be careful when removing the bolts as the glass may fall and become damaged.

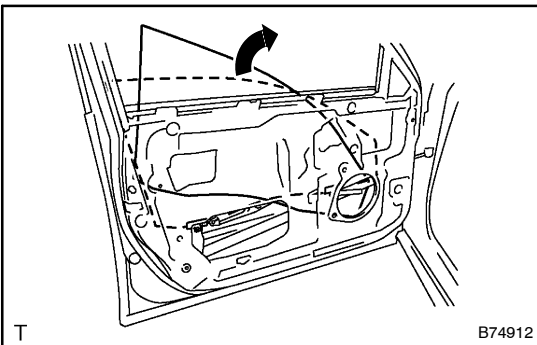

- (c) Move the glass as shown in the illustration to remove it.

NOTICE:

Be careful not to damage the glass.

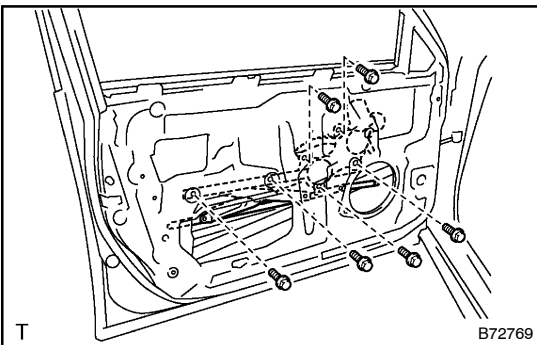

15. REMOVE FRONT DOOR WINDOW REGULATOR SUB-ASSY LH

- (a) Disconnect the window regulator connector.
 (b) Remove the 6 bolts and window regulator.

NOTICE:

Be careful when removing the bolts as the window regulator may fall and become damaged.

HINT:

Remove the window regulator through the service hole.

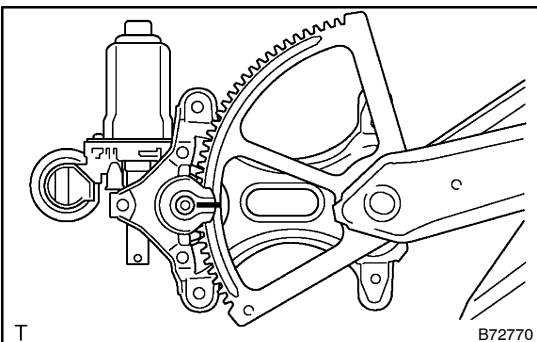

16. REMOVE POWER WINDOW REGULATOR MOTOR ASSY LH FRONT

- (a) Place matchmarks on the window regulator motor bracket and regulator gear.

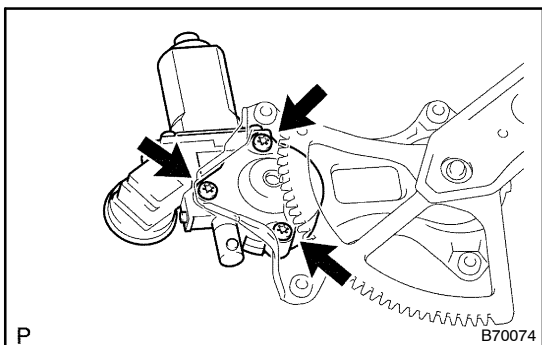

- (b) Using a torx driver (T25), remove the 3 screws and motor.

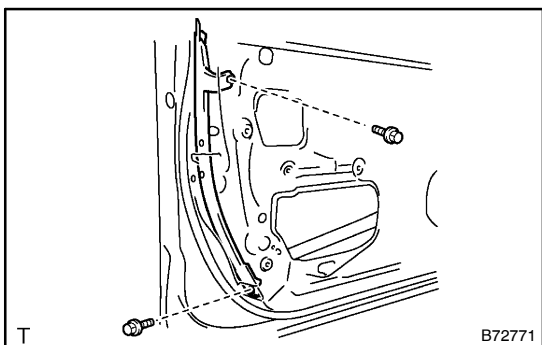

17. REMOVE FRONT DOOR FRAME SUB-ASSY REAR LOWER LH

- (a) Remove the 2 bolts and frame.

NOTICE:

Be careful when removing the bolts as the frame may fall and become damaged.

HINT:

Remove the frame through the service hole.

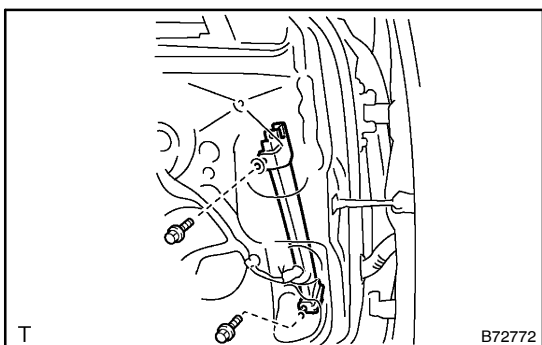

18. REMOVE FRONT DOOR FRAME SUB-ASSY FRONT LOWER LH

- (a) Remove the 2 bolts and frame.

NOTICE:

Be careful when removing the bolts as the frame may fall and become damaged.

HINT:

Remove the frame through the service hole.

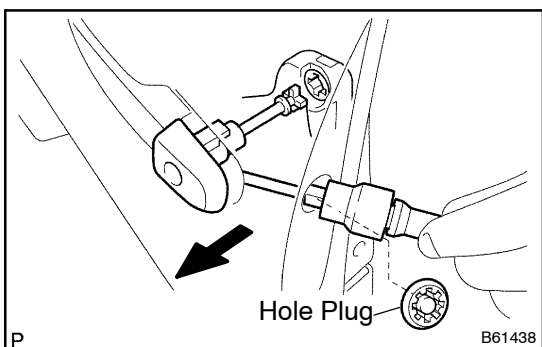

19. REMOVE DOOR OUTSIDE HANDLE COVER ASSY

- (a) Remove the hole plug.
 (b) Using a torx socket wrench (T30), loosen the screw and remove the cover with the door lock key cylinder installed.

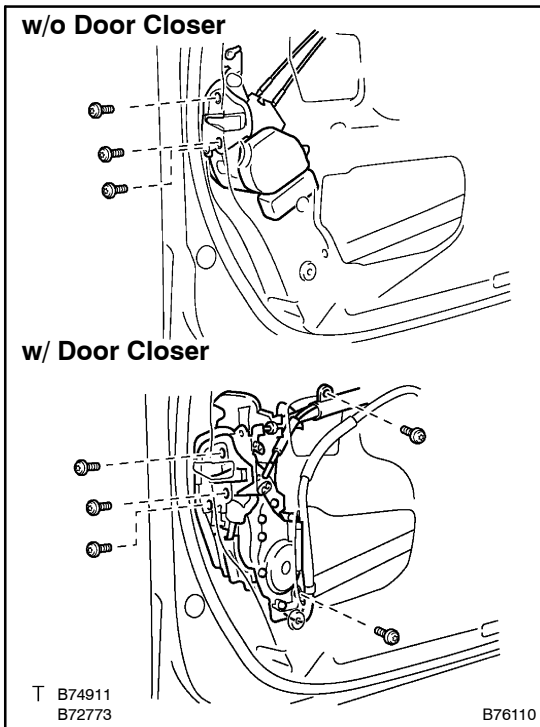
**20. REMOVE FRONT DOOR LOCK ASSY LH**

- (a) Disconnect the door lock connector.
- (b) w/o Door closer:
Using a torx socket wrench (T30), remove the 3 screws and door lock.
- (c) w/ Door closer:
Using a torx socket wrench (T30), remove the 5 screws and door lock.

NOTICE:

Be careful when removing the bolts as the door lock may fall and become damaged.

HINT:

Remove the door lock through the service hole.

- (d) Remove the door remote control cable and door inside locking cable.

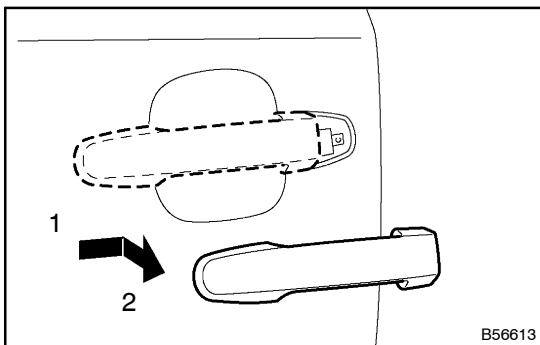
**21. REMOVE FRONT DOOR HANDLE ASSY OUTSIDE LH**

- (a) Disconnect the connector.
- (b) Remove the handle by sliding and pulling it in the direction indicated by the arrow mark in the illustration.
- (c) Remove the outside handle pad front and rear.

NOTICE:

If the release plate is not pulled and held when removing the handle, the release plate will interfere with the handle and become damaged.

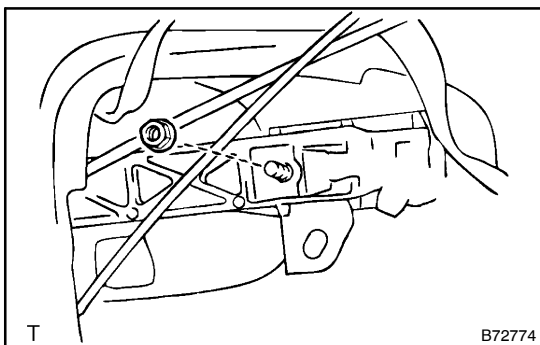
**22. REMOVE FRONT DOOR OUTSIDE HANDLE FRAME SUB-ASSY LH**

- (a) Remove the nut and outside handle frame.

NOTICE:

Be careful when removing the bolts as the frame may fall and become damaged.

HINT:

Remove the frame through the service hole.

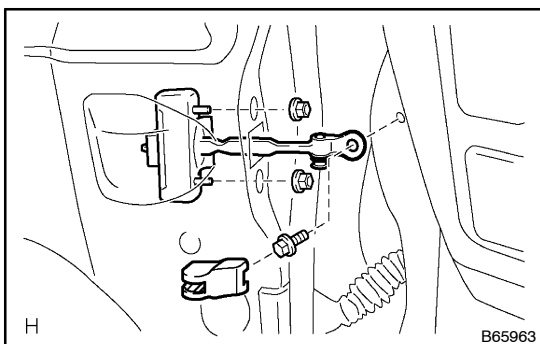
**23. REMOVE FRONT DOOR CHECK ASSY LH**

- (a) Remove the cover.
- (b) Remove the bolt, 2 nuts and door check.

NOTICE:

Be careful when removing the bolts as the door check may fall and become damaged.

HINT:

Remove the door check through the service hole.

24. REMOVE FRONT DOOR WEATHERSTRIP LH

- (a) Using a clip remover, disengage the clips and remove the weatherstrip.

HINT:

If clips are damaged during removal, replace them.

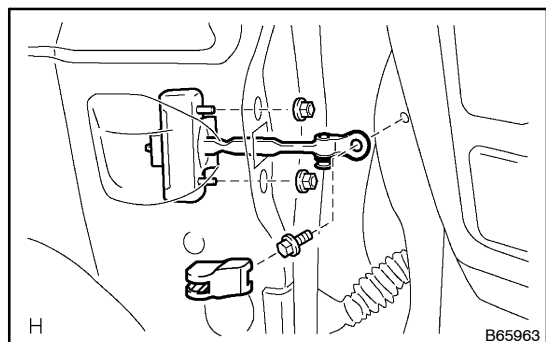
**25. INSTALL FRONT DOOR CHECK ASSY LH**

- (a) Apply MP grease to the sliding areas of the door check.
 (b) Install the door check to the door panel with the 2 nuts.
Torque: 8.0 N·m (82 kgf·cm, 71 in·lbf)
 (c) Apply adhesive to the threads of the bolt.
Adhesive:
Part No. 08833-00070, THREE BOND 1324 or equivalent
 (d) Install the door check to the body panel with the bolt.
Torque: 27 N·m (275 kgf·cm, 20 ft·lbf)
 (e) Install the cover.

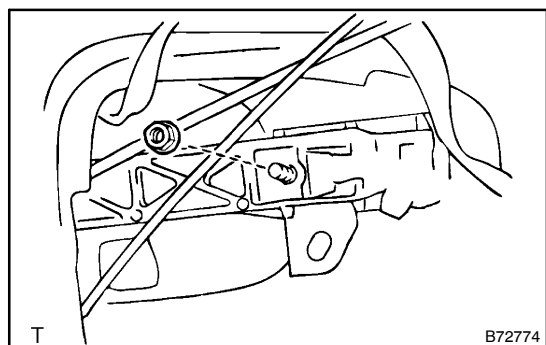
**26. INSTALL FRONT DOOR OUTSIDE HANDLE FRAME SUB-ASSY LH**

- (a) Apply MP grease to the sliding areas of the frame.
 (b) Install the frame with the nut.
Torque: 5.5 N·m (56 kgf·cm, 49 in·lbf)

NOTICE:

A cover should be inserted between the nut and the door panel.

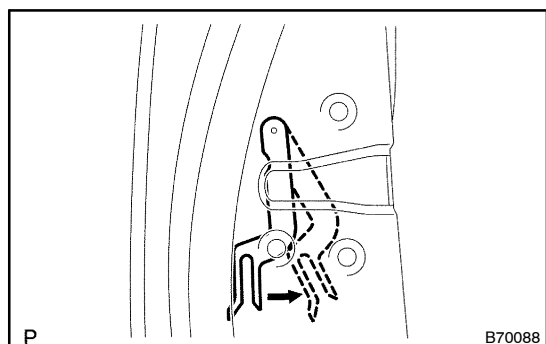
**27. INSTALL FRONT DOOR HANDLE ASSY OUTSIDE LH**

- (a) Install the outside handle pad front and rear.
 (b) Pull and hold the release plate of the frame as shown in the illustration.

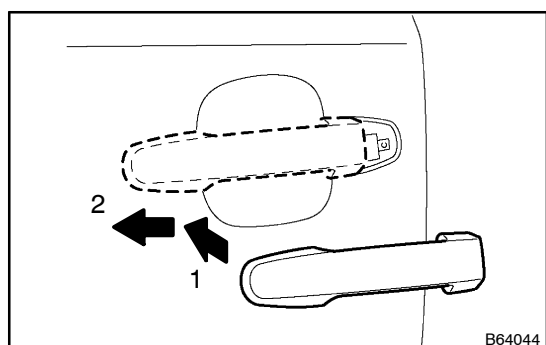

- (c) Install the handle by pushing it in the direction indicated by the arrow marks in the illustration.

NOTICE:

If the release plate is not pulled and held when installing the handle, the release plate will interfere with the handle and become damaged.

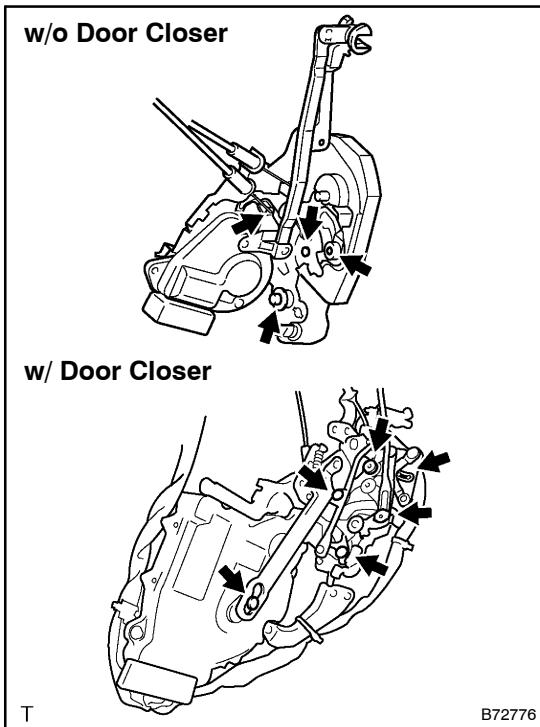
**28. INSTALL FRONT DOOR LOCK ASSY LH**

- (a) Apply MP grease to the sliding and rotating areas of the door lock.

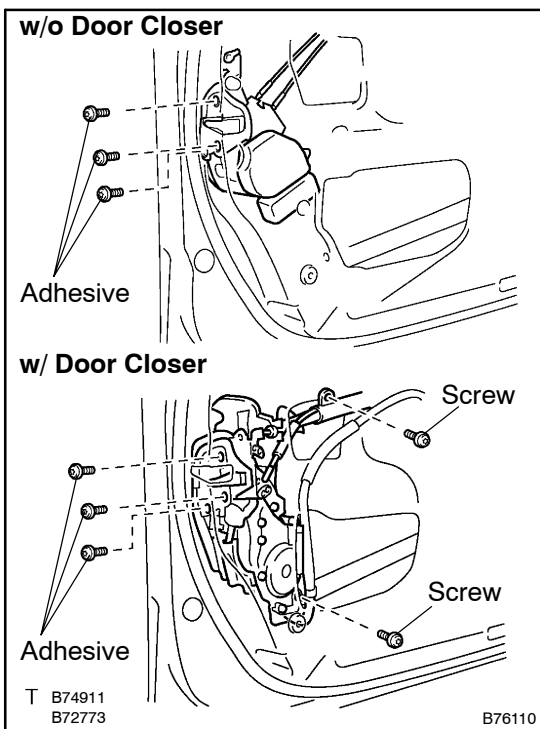

- (b) Apply adhesive to the threads of the 3 screws.

Adhesive:

Part No. 08833-00070, THREE BOND 1324 or equivalent

- (c) Using a torx socket wrench (T30), install the door lock with the 3 screws.

Torque: 5.5 N·m (56 kgf·cm, 49 in·lbf)

- (d) w/ Door closer:

Using a torx socket wrench (T30), install the 2 screws.

Torque: 5.5 N·m (56 kgf·cm, 49 in·lbf)

- (e) Connect the door lock connector.

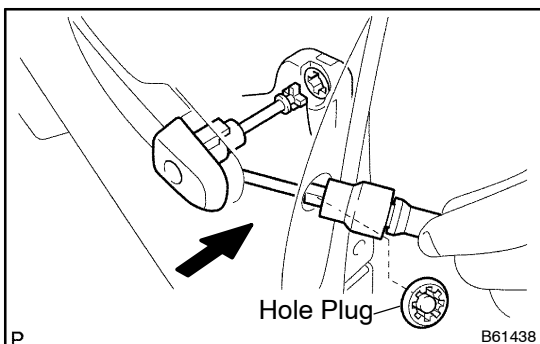
**29. INSTALL DOOR OUTSIDE HANDLE COVER ASSY**

- (a) Using a torx socket wrench (T30), install the outside handle cover with the screw.

Torque: 5.5 N·m (56 kgf·cm, 49 in·lbf)

- (b) Install the hole plug.

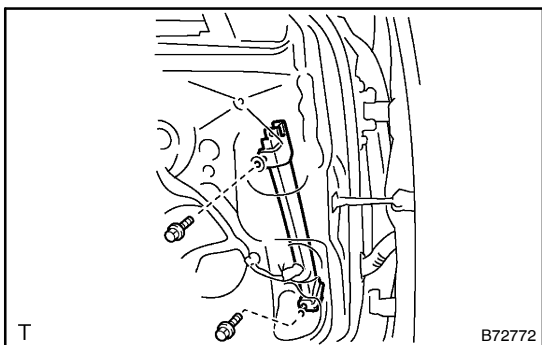

30. INSTALL FRONT DOOR FRAME SUB-ASSY FRONT LOWER LH

- (a) Install the frame with the 2 bolts.
Torque: 8.0 N·m (82 kgf·cm, 71 in·lbf)

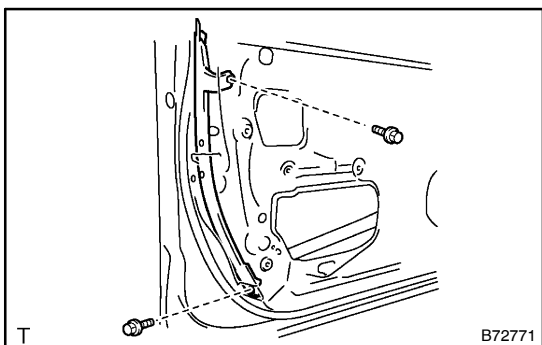

31. INSTALL FRONT DOOR FRAME SUB-ASSY REAR LOWER LH

- (a) Install the frame with the 2 bolts.
Torque: 8.0 N·m (82 kgf·cm, 71 in·lbf)

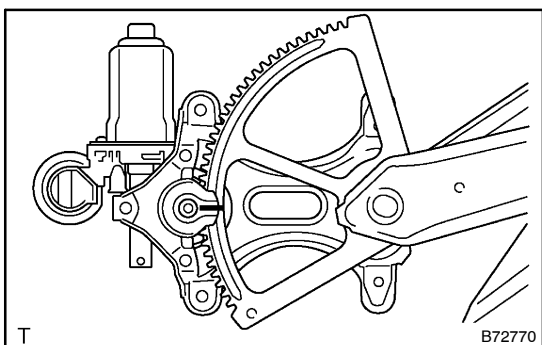

32. INSTALL POWER WINDOW REGULATOR MOTOR ASSY LH FRONT

- (a) Align the matchmarks. Keep them aligned until the window glass installation is complete.

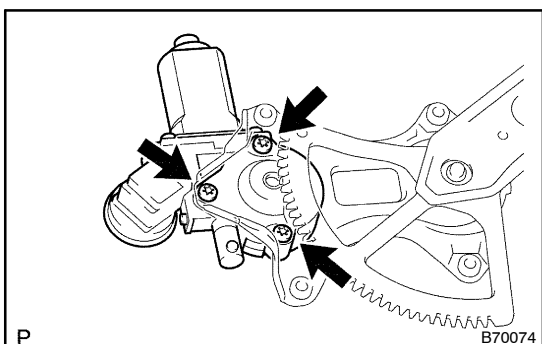

- (b) Using a torx driver (T25), install the motor with the 3 screws.

Torque: 5.5 N·m (56 kgf·cm, 49 in·lbf)

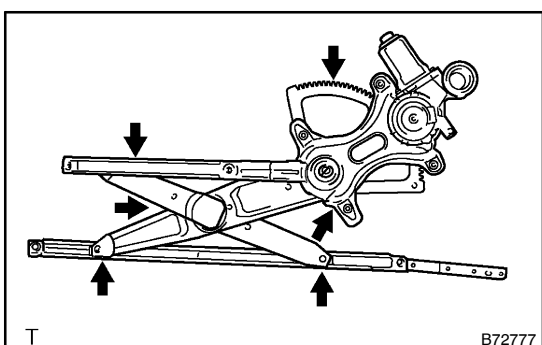

33. INSTALL FRONT DOOR WINDOW REGULATOR SUB-ASSY LH

- (a) Apply MP grease to the sliding and rotating areas of the window regulator.

NOTICE:

Do not apply grease to the spring of the window regulator.

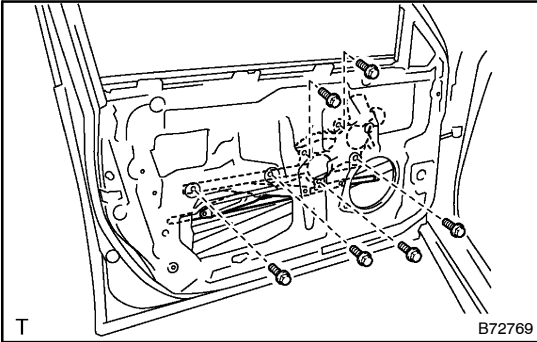

- (b) Install the window regulator with the 6 bolts.
Torque: 11 N·m (115 kgf·cm, 8 ft·lbf)

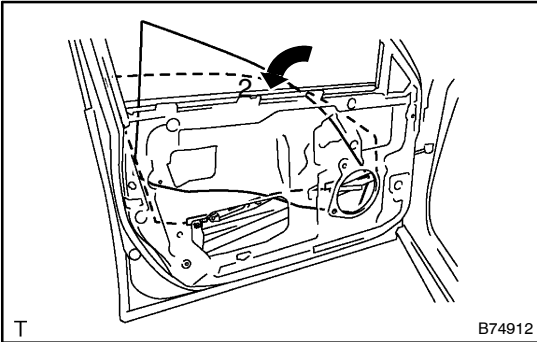

34. INSTALL FRONT DOOR GLASS SUB-ASSY LH

- (a) Insert the door glass into the door panel along the glass run as indicated by the arrow mark in the illustration.

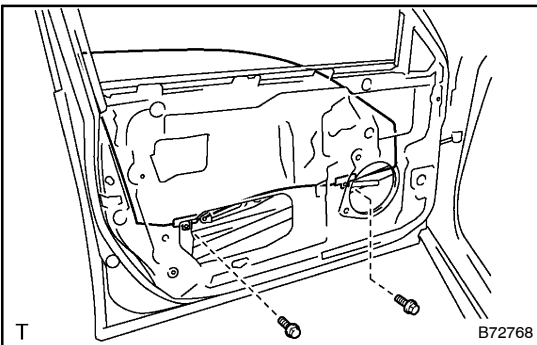

- (b) Install the door glass to the window regulator with the 2 bolts.

Torque: 5.5 N·m (56 kgf·cm, 49 in·lbf)

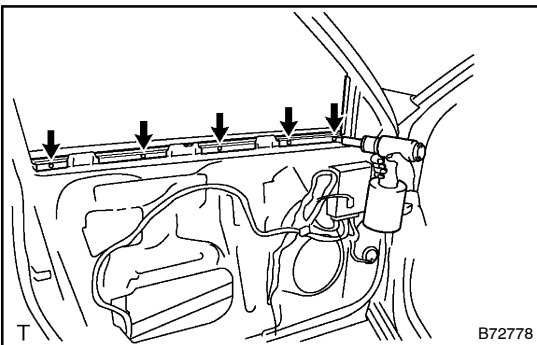

35. INSTALL FRONT DOOR GLASS RUN LH

- (a) Using a hand riveter or an air riveter, install the glass run to the door with the 5 rivets.

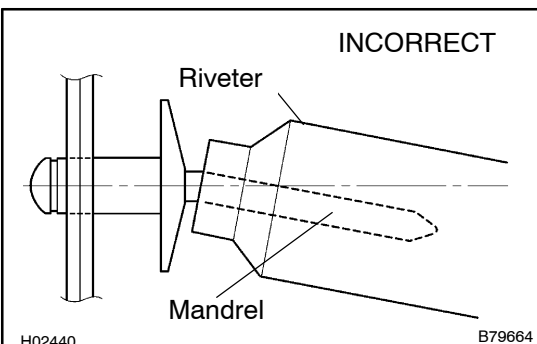

NOTICE:

- Do not prize the riveter. The riveter will be damaged and the mandrel will bend.

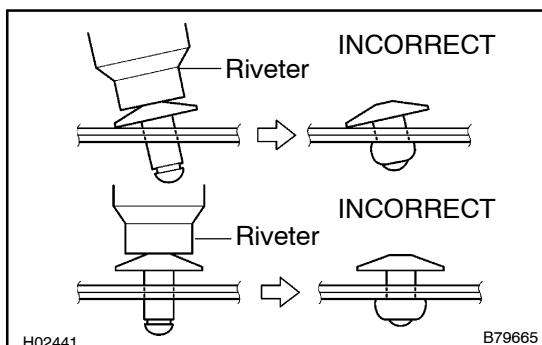

- Do not tilt the riveter when fastening the rivet to the glass run as this will cause the rivet to be loose.
- Do not have any space between the rivet head and the glass run. The rivet head must be completely flat against the glass run.

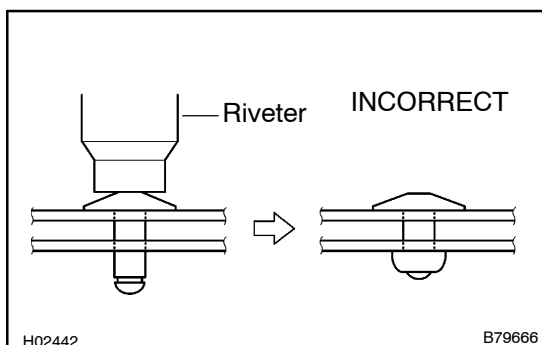

- Do not have any space between the glass runs. Firmly hold together the two items while installing the rivet.
- (b) Connect the speaker connector.

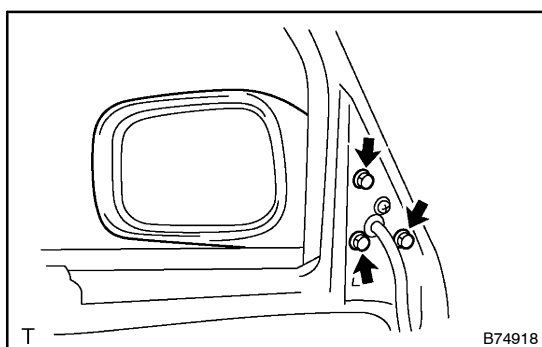

36. INSTALL OUTER REAR VIEW MIRROR ASSY LH

- (a) Install the mirror with the 3 bolts.
Torque: 5.5 N·m (56 kgf·cm, 49 in.·lb)
- (b) Connect the mirror connector.

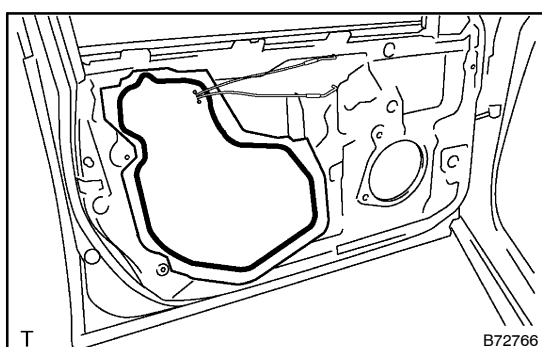

37. INSTALL FRONT DOOR SERVICE HOLE COVER LH

- (a) Apply butyl tape to the door as shown in the illustration.
- (b) Install a new service hole cover.

HINT:

- When installing the service hole cover, pull out the links and connectors through the service hole cover.
- There should be no wrinkles or folds after attaching the service hole cover.
- After attaching the service hole cover, check the sealing quality.

- (c) Connect the 2 connectors and install the wire.
- (d) Install the door electrical key oscillator with 2 screws.

38. INITIALIZE POWER WINDOW SYSTEM (See page 05-1984)