

<b>Last Modified:</b> 5-25-2010	6.4 R	<b>From:</b> 200907
<b>Model Year:</b> 2010	<b>Model:</b> HS250H	<b>Doc ID:</b> RM000001WLL00CX
<b>Title:</b> DOOR / HATCH: LUGGAGE COMPARTMENT DOOR OPENER SYSTEM: PARTS LOCATION (2010 HS250H)		

## **PARTS LOCATION**

## **ILLUSTRATION**

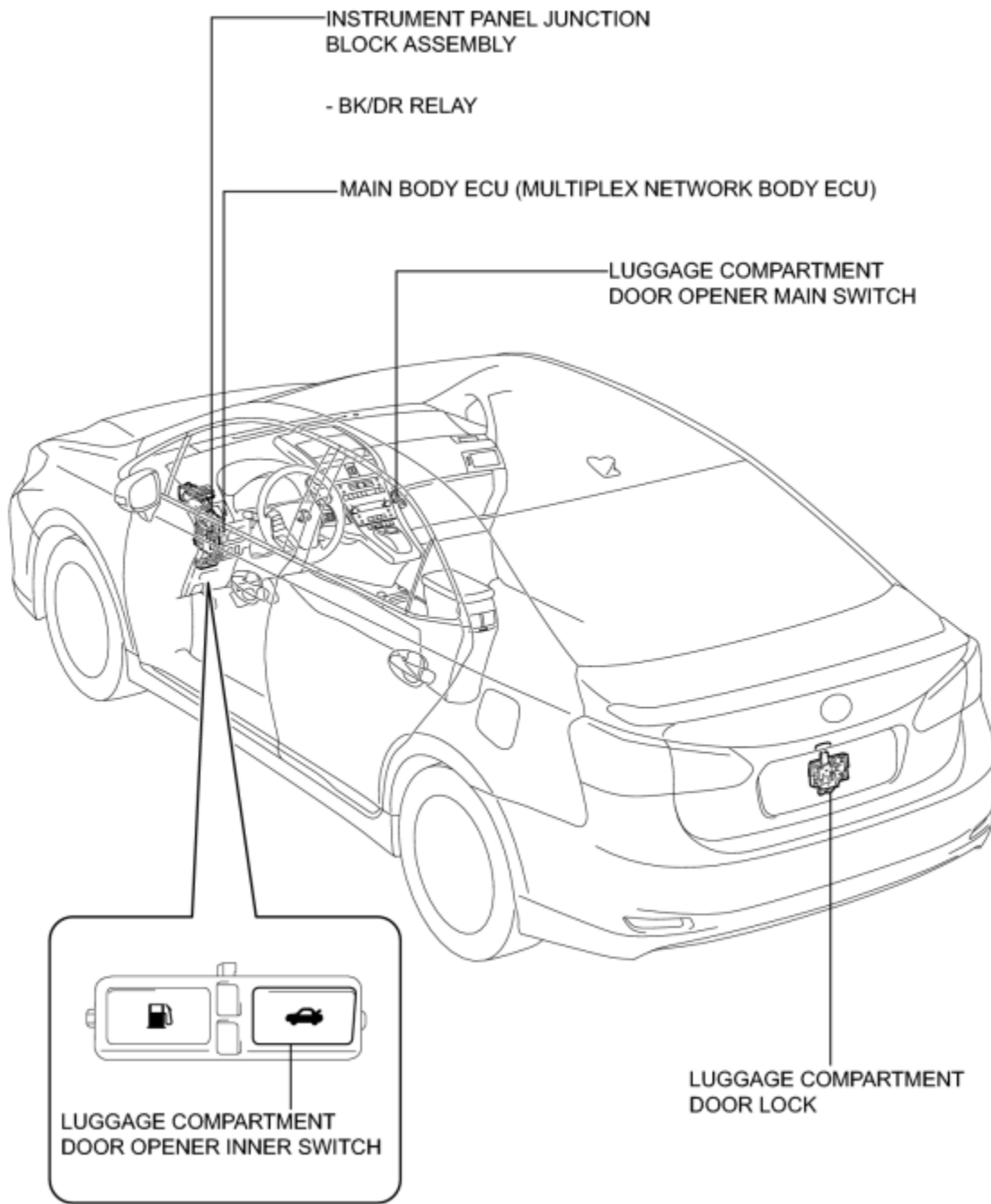

Last Modified: 5-25-2010

6.4 U

From: 200907

<b>Model Year:</b> 2010	<b>Model:</b> HS250H	<b>Doc ID:</b> RM00000418F002X
<b>Title:</b> DOOR / HATCH: LUGGAGE COMPARTMENT DOOR OPENER SYSTEM: SYSTEM DIAGRAM (2010 HS250H)		

## SYSTEM DIAGRAM

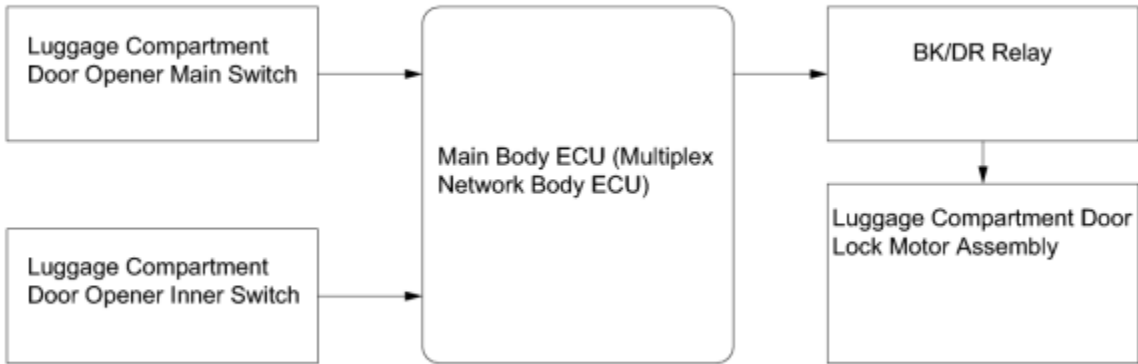

### Communication Table

Sender	Receiver	Signal	Line
Luggage Compartment Door Opener Inner Switch	Main body ECU (multiplex network body ECU)	Luggage compartment door opener inner switch signal	Local communication
Luggage Compartment Door Opener Main Switch	Main body ECU (multiplex network body ECU)	Luggage compartment door opener main switch signal	Local communication

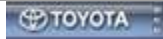

<b>Last Modified:</b> 5-25-2010	6.4 D	<b>From:</b> 200907
<b>Model Year:</b> 2010	<b>Model:</b> HS250H	<b>Doc ID:</b> RM000001SHG00IX
<b>Title:</b> DOOR / HATCH: LUGGAGE COMPARTMENT DOOR OPENER SYSTEM: SYSTEM DESCRIPTION (2010 HS250H)		

## SYSTEM DESCRIPTION

## 1. LUGGAGE COMPARTMENT DOOR OPENER SYSTEM DESCRIPTION

(a) The luggage compartment door opener is an electric type.

(b) The main body ECU (multiplex network body ECU) activates the luggage compartment door lock motor when the ON signal from the luggage compartment door opener inner switch is received.

(c) The luggage compartment door opener system operates as follows:

Opener Main Switch Condition	Opener Inner Switch Condition	Door Lock Condition	Luggage Compartment Door Opener System Condition
ON (Pushed)	Pushed (ON)	Locked	Does not operate
ON (Pushed)	Not pushed (OFF)	Locked	Does not operate
ON (Pushed)	Pushed (ON)	Unlocked	Operates
OFF (Not pushed)	Pushed (ON)	Unlocked	Does not operate

## 2. FUNCTION OF MAIN COMPONENTS

Component	Function
Luggage Compartment Door Lock Motor Assembly	Controlled by main body ECU (multiplex network body ECU) and unlatches luggage compartment door lock.
Luggage Compartment Door Opener Inner Switch	When luggage compartment door opener inner switch is pushed, opener inner switch ON signal is sent to main body ECU (multiplex network body ECU).
Luggage Compartment Door Opener Main Switch	When luggage compartment door opener main switch is pushed, opener main switch ON signal is sent to main body ECU (multiplex network body ECU).
Main Body ECU (multiplex network body ECU)	When luggage compartment door opener inner switch is pushed, main body ECU (multiplex network body ECU) receives opener inner switch ON signal.  When luggage door opener main switch is pushed, main body ECU (multiplex network body ECU) receives opener main switch ON signal.



<b>Last Modified:</b> 5-25-2010	6.4 D	<b>From:</b> 200907
<b>Model Year:</b> 2010	<b>Model:</b> HS250H	<b>Doc ID:</b> RM0000025VO00VX
<b>Title:</b> DOOR / HATCH: LUGGAGE COMPARTMENT DOOR OPENER SYSTEM: OPERATION CHECK (2010 HS250H)		

# OPERATION CHECK

## 1. CHECK LUGGAGE COMPARTMENT DOOR OPENER OPERATION

### NOTICE:

- To prevent inadvertent operation of the luggage compartment door, the opener does not operate while driving.
- When the theft deterrent system is in the armed state or alarm sounding state, the luggage compartment door opener does not operate.

(a) When the luggage compartment door opener main switch is on, push the luggage compartment door opener inner switch and check that the luggage compartment door opens.

(b) When the luggage compartment door opener main switch is off, push the luggage compartment door opener inner switch and check that the luggage compartment door does not open.

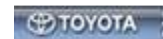

<b>Last Modified:</b> 5-25-2010	6.4 T	<b>From:</b> 200907
<b>Model Year:</b> 2010	<b>Model:</b> HS250H	<b>Doc ID:</b> RM000001SHF00IX
<b>Title:</b> DOOR / HATCH: LUGGAGE COMPARTMENT DOOR OPENER SYSTEM: PROBLEM SYMPTOMS TABLE (2010 HS250H)		

## PROBLEM SYMPTOMS TABLE

### HINT:

- Use the table below to help determine the cause of problem symptoms. If multiple suspected areas are listed, the potential causes of the symptoms are listed in order of probability in the "Suspected Area" column of the table. Check each symptom by checking the suspected areas in the order they are listed. Replace parts as necessary.
- Inspect the fuses and relays related to this system before inspecting the suspected areas below.

### *Luggage Compartment Door Opener System*

Symptom	Suspected Area	See page
Luggage compartment door opener does not operate	Luggage compartment door lock assembly	<a href="#">INFO</a>

	Luggage compartment door opener inner switch	-
	Luggage compartment door opener main switch	-
	Main body ECU (multiplex network body ECU)	-
	Wire harness or connector	-

<b>Last Modified:</b> 5-25-2010	6.4 U	<b>From:</b> 200907
<b>Model Year:</b> 2010	<b>Model:</b> HS250H	<b>Doc ID:</b> RM000001TFW00IX
<b>Title:</b> DOOR / HATCH: LUGGAGE COMPARTMENT DOOR OPENER SYSTEM: TERMINALS OF ECU (2010 HS250H)		

## TERMINALS OF ECU

### 1. CHECK MAIN BODY ECU (Multiplex NETWORK BODY ECU)

(a) Disconnect the 2B, 2C and F7 connectors.

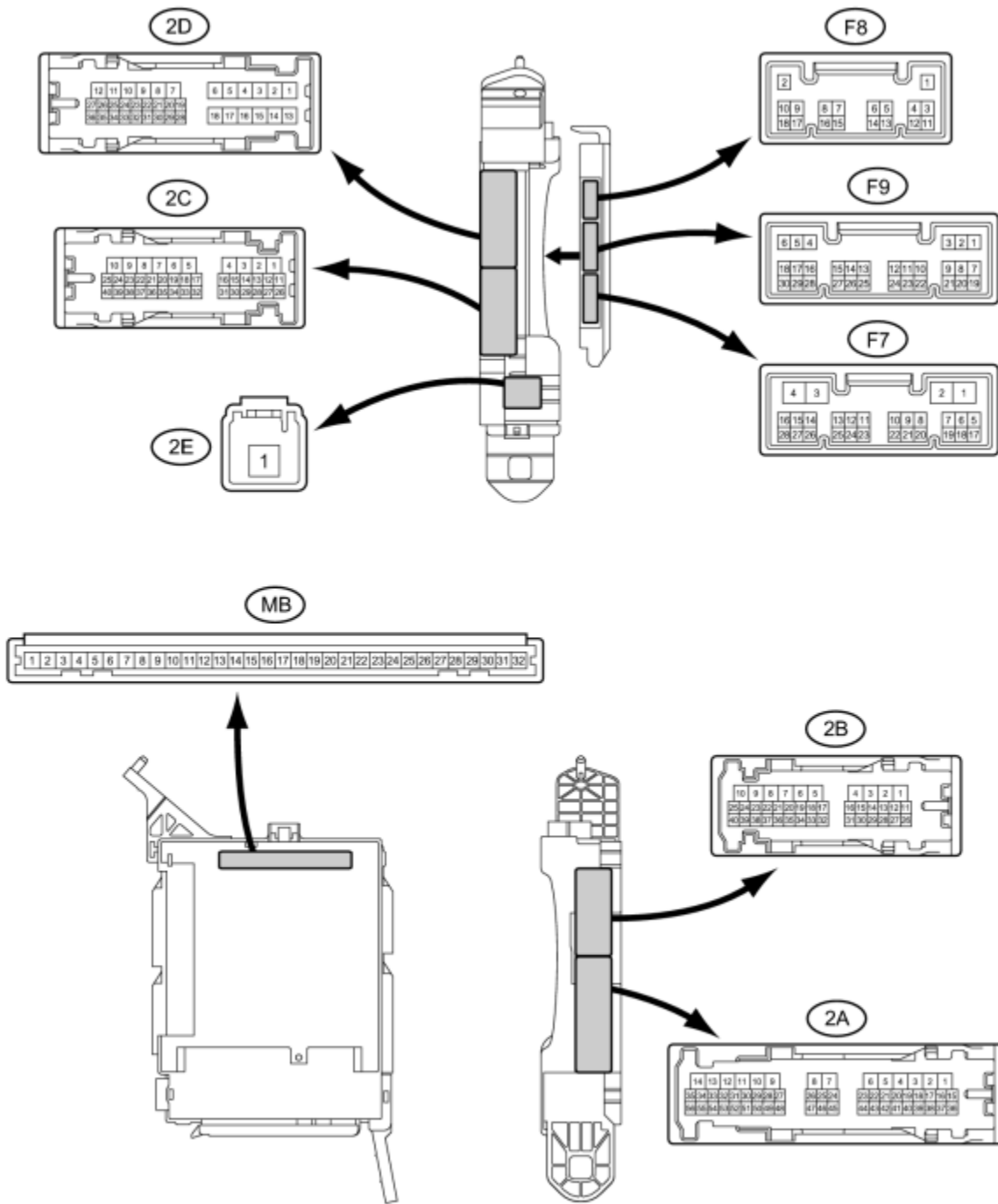

(b) Measure the resistance and voltage according to the value(s) in the table below.

<b>Tester Connection</b>	<b>Wiring Color</b>	<b>Terminal Description</b>	<b>Condition</b>	<b>Specified Condition</b>
2C-18 (BECU) - Body ground	R - Body ground	ECU power supply	Power switch off	11 to 14 V
2B-6 (GND1) - Body ground	W-B - Body ground	Ground	Always	Below 1 $\Omega$
F7-3 (GND2) - Body ground	W-B - Body ground	Ground	Always	Below 1 $\Omega$
F7-11 (TMSW) - Body ground	R - Body ground	Luggage compartment door opener main switch signal input	Luggage compartment door opener main switch off	10 k $\Omega$ or higher
F7-11 (TMSW) - Body ground	R - Body ground	Luggage compartment door opener main switch signal input	Luggage compartment door opener main switch on	Below 1 $\Omega$
F7-5 (TSW) - Body ground	W - Body ground	Luggage compartment door opener inner switch signal input	Luggage compartment door opener inner switch off	10 k $\Omega$ or higher
F7-5 (TSW) - Body ground	W - Body ground	Luggage compartment door opener inner switch signal input	Luggage compartment door opener inner switch on	Below 1 $\Omega$

If the result is not as specified, there may be a malfunction on the wire harness side.

(c) Reconnect the 2B, 2C and F7 connectors.

(d) Measure the voltage according to the value(s) in the table below.

<b>Tester Connection</b>	<b>Wiring Color</b>	<b>Terminal Description</b>	<b>Condition</b>	<b>Specified Condition</b>
2D-9 - Body ground	B - Body ground	Luggage compartment door lock motor drive output	Power switch on (IG) Luggage compartment door opener inner switch off	Below 1 V
2D-9 - Body ground	B - Body ground	Luggage compartment door lock motor drive output	Power switch on (IG) Luggage compartment door opener inner switch on	11 to 14 V



If the result is not as specified, the main body ECU (multiplex network body ECU) or instrument panel junction block assembly may have a malfunction.



<b>Last Modified:</b> 5-25-2010	6.4 D	<b>From:</b> 200907
<b>Model Year:</b> 2010	<b>Model:</b> HS250H	<b>Doc ID:</b> RM000000VPI00SX
<b>Title:</b> DOOR / HATCH: LUGGAGE COMPARTMENT DOOR OPENER SYSTEM: DIAGNOSIS SYSTEM (2010 HS250H)		

## DIAGNOSIS SYSTEM

### 1. CHECK DLC3

(a) Check the DLC3 .

### 2. INSPECT AUXILIARY BATTERY VOLTAGE

(a) Measure the auxiliary battery voltage with the power switch off.

Standard Voltage:

11 to 14 V

If voltage is below 11 V, recharge or replace the auxiliary battery.

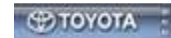

<b>Last Modified:</b> 5-25-2010	6.4 U	<b>From:</b> 200907
<b>Model Year:</b> 2010	<b>Model:</b> HS250H	<b>Doc ID:</b> RM000000VPK00ZX
<b>Title:</b> DOOR / HATCH: LUGGAGE COMPARTMENT DOOR OPENER SYSTEM: DATA LIST / ACTIVE TEST (2010 HS250H)		

## DATA LIST / ACTIVE TEST

### 1. DATA LIST

HINT:

Using the Techstream to read the Data List allows the values or states of switches, sensors,

actuators and other items to be read without removing any parts. This non-intrusive inspection can be very useful because intermittent conditions or signals may be discovered before parts or wiring is disturbed. Reading the Data List information early in troubleshooting is one way to save diagnostic time.

**NOTICE:**

In the table below, the values listed under "Normal Condition" are reference values. Do not depend solely on these reference values when deciding whether a part is faulty or not.

- (a) Connect the Techstream to the DLC3.
- (b) Turn the power switch on (IG).
- (c) Turn the Techstream on.
- (d) Enter the following menus: Body Electrical / Main Body / Data List.
- (e) Read the Data List according to the display on the Techstream.

**Main Body**

Tester Display	Measurement Item/Range	Normal Condition	Diagnostic Note
Trunk/BDoor Open SW	Luggage door opener inner switch signal/ON or OFF	ON: Luggage compartment door opener inner switch pushed OFF: Luggage compartment door opener inner switch not pushed	-
Trunk Main SW	Luggage door opener main switch signal/ON or OFF	ON: Luggage compartment door opener main switch pushed OFF: Luggage compartment door opener main switch not pushed	-

**2. ACTIVE TEST**

**HINT:**

Using the Techstream to perform Active Tests allows relays, VSVs, actuators and other items to be operated without removing any parts. This non-intrusive functional inspection can be very useful because intermittent operation may be discovered before parts or wiring is disturbed. Performing Active Tests early in troubleshooting is one way to save diagnostic time. Data List

information can be displayed while performing Active Tests.

- (a) Connect the Techstream to the DLC3.
- (b) Turn the power switch on (IG).
- (c) Turn the Techstream on.
- (d) Enter the following menus: Body Electrical / Main Body / Active Test.
- (e) Perform the Active Test according to the display on the Techstream.

**Main Body**

Tester Display	Test Part	Control Range	Diagnostic Note
Trunk and Back-Door Open	Operate luggage compartment door lock motor	ON/OFF	This test will open the trunk



<b>Last Modified:</b> 5-25-2010	6.4 J	<b>From:</b> 200907
<b>Model Year:</b> 2010	<b>Model:</b> HS250H	<b>Doc ID:</b> RM000001SHK00LX

**Title:** DOOR / HATCH: LUGGAGE COMPARTMENT DOOR OPENER SYSTEM: Luggage Compartment Door Opener does not Operate (2010 HS250H)

Luggage Compartment Door Opener does not Operate

## DESCRIPTION

When the main body ECU (multiplex network body ECU) has received the ON signal from the luggage compartment opener main switch and the ON signal from the luggage compartment door opener inner switch, the main body ECU (multiplex network body ECU) activates the luggage compartment door lock motor.

## WIRING DIAGRAM

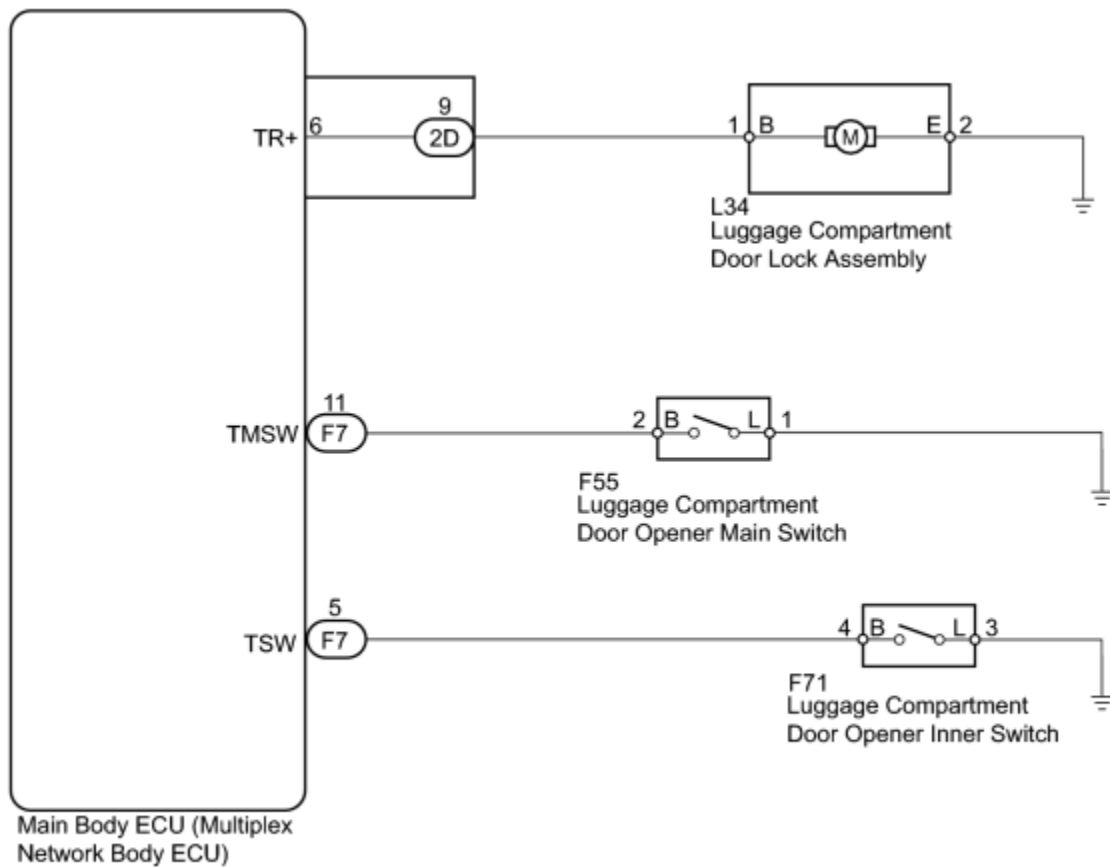

## INSPECTION PROCEDURE

NOTICE:

Inspect the fuses for circuits related to this system before performing the following inspection procedure.

## PROCEDURE

1.

CHECK LUGGAGE COMPARTMENT DOOR OPENER SYSTEM (LUGGAGE COMPARTMENT DOOR OPENER MAIN SWITCH)

(a) When the luggage compartment door opener main switch is on, push the luggage compartment door opener inner switch and check that the luggage compartment door

\*1

opens.

OK:

Luggage compartment door opener system operates normally.

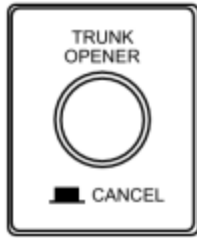

(b) When the luggage compartment door opener main switch is off, push the luggage compartment door opener inner switch and check that the luggage compartment door does not open.

OK:

Luggage compartment door opener system does not operate.

*Text in Illustration*

*1	Luggage Compartment Door Opener Main Switch
NG	<a href="#">▶ PERFORM ACTIVE TEST USING TECHSTREAM</a>
OK	<a href="#">▶ END</a>
2.	PERFORM ACTIVE TEST USING TECHSTREAM

(a) Connect the Techstream to the DLC3.

(b) Turn the power switch on (IG).

(c) Turn the Techstream on.

(d) Enter the following menus: Body Electrical / Main Body / Active Test.

(e) Perform the Active Test according to the display on the Techstream.

*Main Body*

Tester Display	Test Part	Control Range	Diagnostic Note
----------------	-----------	---------------	-----------------

Trunk and Back-Door Open	Operate luggage compartment door lock motor	ON/OFF	This test will open the trunk
--------------------------	---	--------	-------------------------------

OK:

Luggage compartment door lock motor operates.

NG  [INSPECT LUGGAGE COMPARTMENT DOOR LOCK ASSEMBLY](#)

OK



3.	READ VALUE USING TECHSTREAM
----	-----------------------------

- (a) Connect the Techstream to the DLC3.
- (b) Turn the power switch on (IG).
- (c) Turn the Techstream on.
- (d) Enter the following menus: Body Electrical / Main Body / Data List.
- (e) Read the Data List according to the display on the Techstream.

**Main Body**

Tester Display	Measurement Item/Range	Normal Condition	Diagnostic Note
Trunk/BDoor Open SW	Luggage door opener inner switch signal/ON or OFF	ON: Luggage compartment door opener inner switch is pushed OFF: Luggage compartment door opener inner switch is not pushed	-
Trunk Main SW	Luggage door opener main switch signal/ON or OFF	ON: Luggage compartment door opener main switch is pushed OFF: Luggage compartment door opener main switch is not pushed	-

OK:

On the Techstream screen, each item changes between ON and OFF according to the above.

Result:

Result	Proceed to
NG (Luggage compartment door opener inner switch is abnormal)	A
NG (Luggage compartment door opener main switch is abnormal)	B
OK (Luggage compartment door opener main switch and luggage compartment door opener inner switch are normal)	C

C ▶ [REPLACE MAIN BODY ECU \(MULTIPLEX NETWORK BODY ECU\)](#)

B ▶ [INSPECT LUGGAGE COMPARTMENT DOOR OPENER MAIN SWITCH](#)

A



4.	INSPECT LUGGAGE COMPARTMENT DOOR OPENER INNER SWITCH
----	--

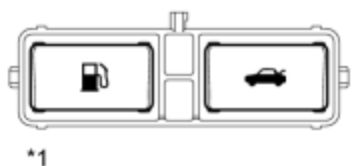

(a) Remove the luggage compartment door opener inner switch INFO.

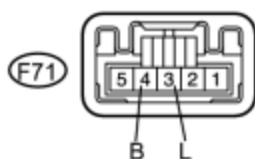

P

(b) Measure the resistance according to the value(s) in the table below.

Standard Resistance:

Tester Connection	Switch Condition	Specified Condition
F71-4 (B) - F71-3 (L)	Pushed (ON)	Below 1 $\Omega$
F71-4 (B) - F71-3 (L)	Not pushed (OFF)	10 k $\Omega$ or higher

*Text in Illustration*

*1	Component without harness connected (Luggage Compartment Door Opener Inner Switch)
----	---

NG ► [REPLACE LUGGAGE COMPARTMENT DOOR OPENER INNER SWITCH](#)

OK



5.	CHECK HARNESS AND CONNECTOR (LUGGAGE COMPARTMENT DOOR OPENER INNER SWITCH - MAIN BODY ECU)
----	--

(a) Disconnect the F7 main body ECU (multiplex network body ECU) connector.

(b) Measure the resistance according to the value(s) in the table below.

Standard Resistance:

Tester Connection	Condition	Specified Condition
F7-5 (TSW) - F71-4 (B)	Always	Below 1 $\Omega$
F7-5 (TSW) - Body ground	Always	10 k $\Omega$ or higher
F71-3 (L) - Body ground	Always	Below 1 $\Omega$

NG ► REPAIR OR REPLACE HARNESS OR CONNECTOR (LUGGAGE COMPARTMENT DOOR OPENER INNER SWITCH - MAIN BODY ECU)

OK ► [REPLACE MAIN BODY ECU \(MULTIPLEX NETWORK BODY ECU\)](#)

6.	INSPECT LUGGAGE COMPARTMENT DOOR OPENER MAIN SWITCH
----	---

\*1

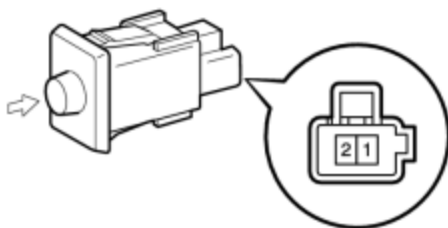

(a) Remove the luggage compartment door opener main switch INFO.



(b) Measure the resistance according to the value(s) in the table below.

Standard Resistance:

Tester Connection	Switch Condition	Specified Condition
F55-1 (L) - F55-2 (B)	Not pushed (OFF)	10 kΩ or higher
F55-1 (L) - F55-2 (B)	Pushed (ON)	Below 1 Ω

*Text in Illustration*

*1	Component without harness connected (Luggage Compartment Door Opener Main Switch)
----	--

NG  [REPLACE LUGGAGE COMPARTMENT DOOR OPENER MAIN SWITCH](#)

OK



7.	CHECK HARNESS AND CONNECTOR (LUGGAGE COMPARTMENT DOOR OPENER MAIN SWITCH - MAIN BODY ECU)
----	---

(a) Disconnect the F7 main body ECU (multiplex network body ECU) connector.

(b) Measure the resistance according to the value(s) in the table below.

Standard Resistance:

Tester Connection	Condition	Specified Condition
F7-11 (TMSW) - F55-2 (B)	Always	Below 1 Ω
F55-1 (L) - Body ground	Always	Below 1 Ω
F7-11 (TMSW) - Body ground	Always	10 kΩ or higher

NG  REPAIR OR REPLACE HARNESS OR CONNECTOR (LUGGAGE COMPARTMENT DOOR OPENER MAIN SWITCH - MAIN BODY ECU)

OK  [REPLACE MAIN BODY ECU \(MULTIPLEX NETWORK BODY ECU\)](#)

8.	INSPECT LUGGAGE COMPARTMENT DOOR LOCK ASSEMBLY
----	--

(a) Remove the luggage compartment door lock assembly



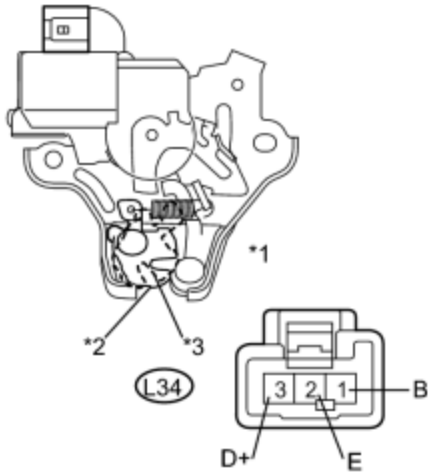

(b) Move the door lock to the closed (locked) position.

(c) Apply auxiliary battery voltage to the door lock motor and check the operation of the door lock motor.

OK:

Connection	Result
Auxiliary battery positive (+) → Terminal 1 (B) Auxiliary battery negative (-) → Terminal 2 (E)	Luggage compartment door lock motor opens door lock

(d) Measure the resistance according to the value(s) in the table below.

Standard Resistance:

Tester Connection	Condition	Specified Condition
L34-3 (D+) - L34-2 (E)	Open (Unlocked)	Below 1 $\Omega$
L34-3 (D+) - L34-2 (E)	Closed (Locked)	10 k $\Omega$ or higher

*Text in Illustration*

*1	Component without harness connected (Luggage Compartment Door Lock Assembly)
*2	Closed (Locked)
*3	Open (Unlocked)

NG  [REPLACE LUGGAGE COMPARTMENT DOOR LOCK ASSEMBLY](#)

OK



9.	CHECK HARNESS AND CONNECTOR (LUGGAGE COMPARTMENT DOOR LOCK ASSEMBLY - MAIN BODY ECU)
----	--

(a) Disconnect the 2D instrument panel junction block assembly connector.

(b) Measure the resistance according to the value(s) in the table below.

Standard Resistance:

Tester Connection	Condition	Specified Condition
L34-1 (B) - 2D-9 (TR+)	Always	Below 1 $\Omega$
L34-1 (B) - Body ground	Always	10 k $\Omega$ or higher
L34-2 (E) - Body ground	Always	Below 1 $\Omega$

NG  REPAIR OR REPLACE HARNESS OR CONNECTOR (LUGGAGE COMPARTMENT DOOR LOCK ASSEMBLY - MAIN BODY ECU)

OK



10.	INSPECT INSTRUMENT PANEL JUNCTION BLOCK
-----	---

(a) Remove the instrument panel junction block assembly

 .

\*1

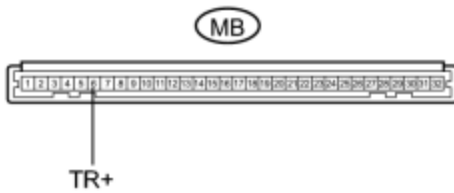
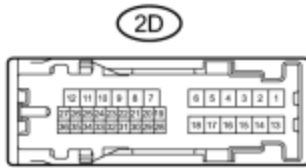

(b) Measure the resistance according to the value(s) in the table below.

Standard Resistance:

Tester Connection	Condition	Specified Condition
MB-6 (TR+) - 2D-9	Always	Below 1 $\Omega$
MB-6 (TR+) - Body ground	Always	10 k $\Omega$ or higher

*Text in Illustration*

*1	Component without harness connected (Instrument Panel Junction Block assembly)
----	---

NG ► [REPLACE INSTRUMENT PANEL JUNCTION BLOCK](#)

OK ► [REPLACE MAIN BODY ECU \(MULTIPLEX NETWORK BODY ECU\)](#)

