

THERMOSTAT > INSTALLATION

for Preparation [Click here](#)

1. INSTALL WATER INLET SUB-ASSEMBLY WITH THERMOSTAT

- a. Install a new gasket and the water inlet with thermostat with the 3 nuts.

Torque:

10 N*m{ 102 kgf*cm , 7 ft.*lbf }

2. CONNECT NO. 2 RADIATOR HOSE

- a. Install the No. 2 radiator hose to the radiator.

Text in Illustration

*1	Paint Mark
*a	Upper Side
*b	RH Side

HINT:

When connecting the hoses, make sure the paint marks and clips are as shown in the illustration.

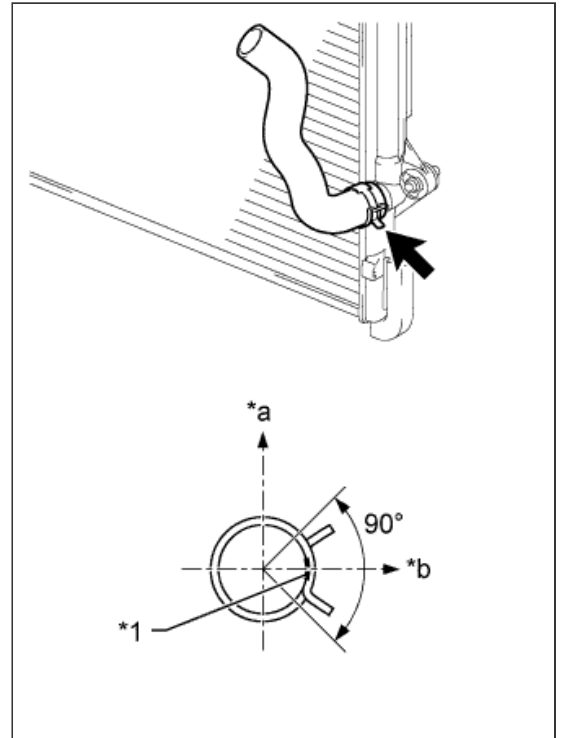

3. INSTALL AIR TUBE SUB-ASSEMBLY

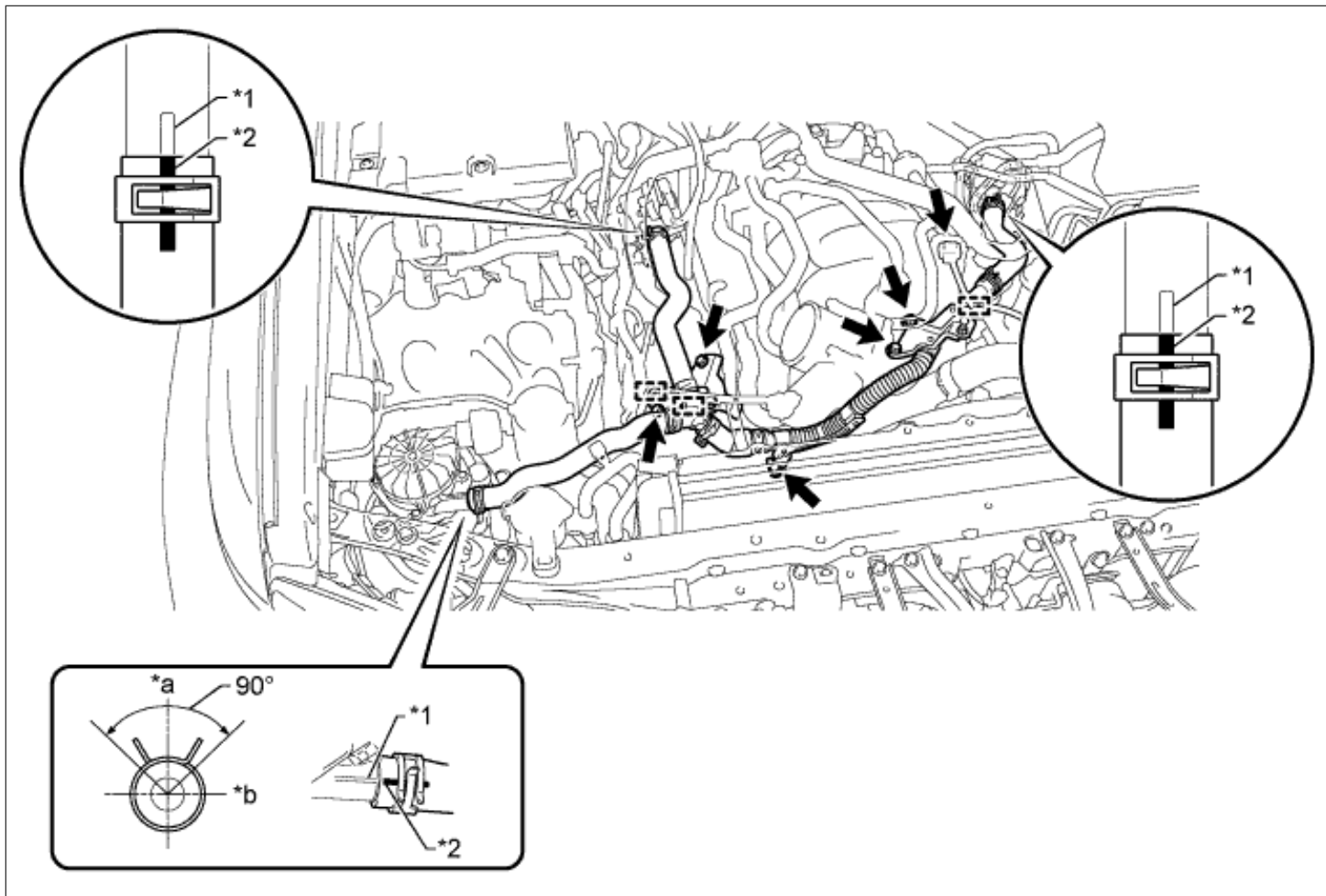

Text in Illustration

*1	Projection	*2	Paint Mark
*a	Top	*b	Front

- a. Temporarily install the air tube with the 5 bolts.
- b. Connect the No. 2 air injection system hose to the air switching valve LH as shown in the illustration.
- c. Connect the manifold absolute pressure sensor connector and clamp.
- d. Attach the 2 wire harness clamps.
- e. Connect the No. 1 air injection system hose to the air switching valve RH as shown in the illustration.
- f. Connect the air hose to the air pump as shown in the illustration.
- g. Tighten the 5 bolts.

Torque:

10 N*m { 102 kgf*cm , 7 ft.*lbf }

4. INSTALL AIR CLEANER CASE SUB-ASSEMBLY

- a. Install the air cleaner case with the 3 bolts.

Torque:

12 N*m { 122 kgf*cm , 9 ft.*lbf }

5. INSTALL AIR CLEANER FILTER ELEMENT SUB-ASSEMBLY

6. INSTALL AIR CLEANER CAP AND HOSE

- a. Attach the 4 clamps to install the air cleaner cap and hose.

Text in Illustration

*1	Air Cleaner Hose
*2	Throttle Body
*3	Groove
*4	Protrusion
*a	Upper Side
*b	Front

HINT:

When installing the air cleaner hose, align its groove with the protrusion of the throttle body as shown in the illustration.

- b. Tighten the hose clamp.

Torque:

5.0 N*m { 51 kgf*cm , 44 in.*lbf }

HINT:

Make sure the direction of the hose clamp is as shown in the illustration.

- c. Connect the mass air flow meter connector, No. 1 air hose and No. 2 ventilation hose and attach the wire harness clamp.

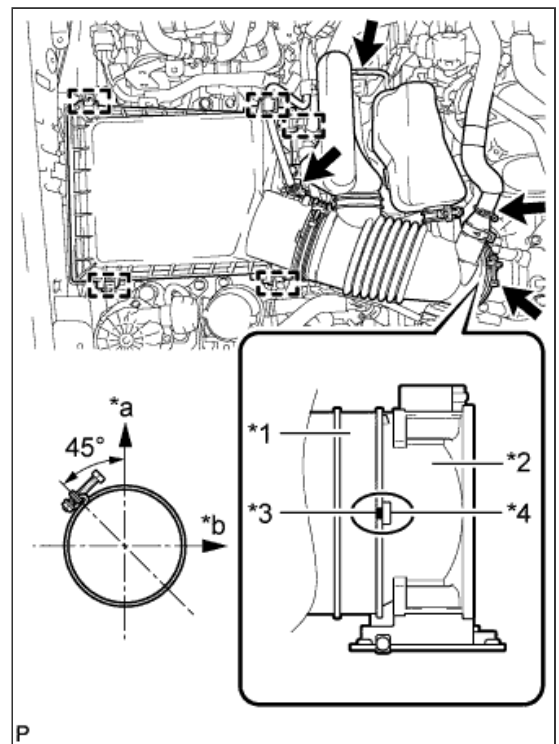

7. ADD ENGINE COOLANT

- a. Add engine coolant.

Standard Capacity:

15.4 liters (16.3 US qts, 13.6 Imp. qts)

NOTICE:

Do not substitute plain water for engine coolant.

HINT:

- **TOYOTA vehicles are filled with TOYOTA SLLC at the factory. In order to avoid damage to the engine cooling system and other technical problems, only use TOYOTA SLLC or similar high quality ethylene glycol based non-silicate, non-amine, non-nitrite, non-borate coolant with long-life hybrid organic acid technology (coolant with long-life hybrid organic acid technology consists of a combination of low phosphates and organic acids).**
 - **Press the No. 1 and No. 2 radiator hoses several times by hand, and then check the coolant level. If the coolant level is low, add coolant.**
- b. Slowly pour coolant into the radiator reservoir until it reaches the F line.
- c. Install the reservoir cap.
- d. Install the radiator cap.*1
- e. Start the engine and stop it immediately.*2
- f. Allow approximately 10 seconds to pass. Then remove the radiator cap and check the coolant level. If the coolant level has decreased, add coolant.*3
- g. Repeat steps *1, *2 and *3 until the coolant level does not decrease.

HINT:

Be sure to perform this step while the engine is cold, as air in the No. 1 radiator hose will flow into the radiator if the engine is warmed up and the thermostat opens.

- h. Install the radiator cap.*4
- i. Set the air conditioning as follows.*5

Item	Condition
Fan speed	Any setting except off
Temperature	Toward WARM
Air conditioning switch	Off

- j. Start the engine, warm it up until the thermostat opens, and then continue to run the engine for several minutes to circulate the coolant.*6

CAUTION:

- **Wear protective gloves. Hot areas on the parts may injure your hands.**
- **Be careful of the fan.**
- **Be careful as the engine, radiator and radiator hoses are hot and can cause burns.**

NOTICE:

- **Immediately after starting the engine, if the radiator reservoir does not have any coolant, perform the following: 1) stop the engine, 2) wait until the coolant has cooled down, and 3) add coolant until the coolant is filled to the F line.**
- **Do not start the engine when there is no coolant in the radiator reservoir.**
- **Pay attention to the needle of the engine coolant temperature receiver gauge. Make sure that the needle does not show an abnormally high temperature.**
- **If there is not enough coolant, the engine may burn out or overheat.**

HINT:

- Press the No. 1 and No. 2 radiator hoses several times by hand to bleed air while warming up the engine.
- The thermostat opening timing can be confirmed by pressing the No. 2 radiator hose by hand and checking when the engine coolant starts to flow inside the hose.

k. Stop the engine and wait until the engine coolant cools down to ambient temperature. Then remove the radiator cap and check the coolant level.*7

CAUTION:

Do not remove the radiator cap while the engine and radiator are still hot. Pressurized, hot engine coolant and steam may be released and cause serious burns.

l. If the coolant level has decreased, add coolant and warm up the engine until the thermostat opens.*8

m. If the coolant level has not decreased, check that the coolant level in the radiator reservoir is at the F line.

If the coolant level is below the F line, repeat steps *4 through *8.

If the coolant level is above the F line, drain coolant until the coolant level reaches the F line.

8. INSPECT FOR COOLANT LEAK

CAUTION:

Do not remove the radiator cap while the engine and radiator are still hot. Pressurized, hot engine coolant and steam may be released and cause serious burns.

a. Fill the radiator with coolant and attach a radiator cap tester.

b. Warm up the engine.

c. Using the radiator cap tester, increase the pressure inside the radiator to 118 kPa (1.2 kgf/cm², 17 psi), and check that the pressure does not drop.

If the pressure drops, check the hoses, radiator and water pump for leaks. If no external leaks are found, check the heater core, cylinder block and head.

9. INSTALL V-BANK COVER SUB-ASSEMBLY

a. Attach the 2 V-bank cover hooks to the No. 1 V-bank cover bracket. Then align the 2 V-bank cover grommets with the 2 pins and press down on the V-bank cover to attach the pins.

Text in Illustration

*1	Pin
*2	Grommet
*3	Hook
*4	No. 1 V-bank Cover Bracket

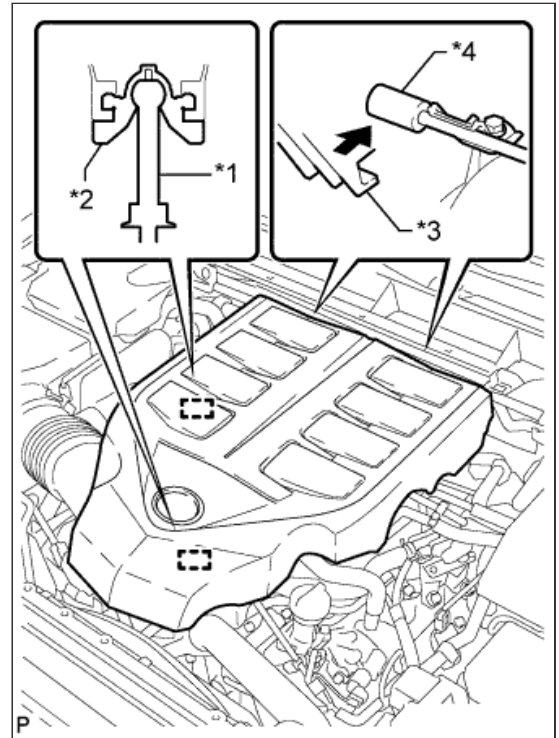

10. INSTALL NO. 1 ENGINE UNDER COVER SUB-ASSEMBLY

- a. Hook the No. 1 engine under cover to the vehicle body as shown in the illustration.
- b. Install the 4 bolts.

Torque:

29 N*m { 296 kgf*cm , 21 ft.*lbf }

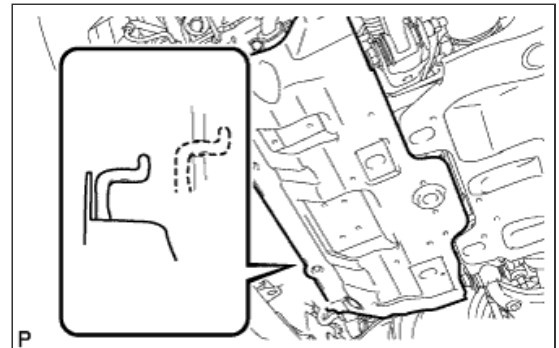

11. INSTALL LOWER FRONT BUMPER COVER

- a. Install the lower front bumper cover with the 5 bolts and clip.

Torque:

8.0 N*m { 82 kgf*cm , 71 in.*lbf }

12. INSTALL UPPER RADIATOR SUPPORT SEAL

- a. Install the upper radiator support seal with the 13 clips.

