

AIR SUSPENSION SYSTEM > DETAILS

FUNCTION OF MAIN COMPONENTS

Component		Function
Height Control Compressor Assembly	Height Control Compressor with Motor	Creates compressed air that is required for raising the vehicle height and supplies it to the rear pneumatic cylinder assembly.
	Height Control Dryer Assembly	Removes moisture in the compressed air.
	Exhaust Solenoid Valve	Discharges compressed air into the atmosphere from the rear pneumatic cylinder assembly to lower the vehicle height.
Height Control Filter		Removes dust and sand from the internal air.
Rear Pneumatic Cylinder Assembly		Supports the vehicle body and adjusts the vehicle height.
No. 2 Height Control Valve Assembly	Leveling Solenoid Valve	Opens and closes the compressed air path between the height control dryer assembly and the rear pneumatic cylinder assembly.
	Gate Solenoid Valve	Opens and closes the compressed air path between the right and left rear pneumatic cylinder assemblies.
Rear Height Control Sensor Sub-assembly		Detects the vehicle height.
Height Control Switch		Selects vehicle height (HI, Normal, or LO).
Height Control OFF Switch		Prohibits vehicle height control.
Suspension Control Relay		Supplies electricity to the height control compressor with motor.
Combination Meter Assembly	Height Control Indicator	Indicates the selected condition of the height control switch.
	Height Control Off Indicator	Indicates the selected condition of the height control OFF switch.
	Multi-information Display	Displays to inform the driver when the suspension control ECU has detected a malfunction in the rear air suspension system.
	Master Warning Light	Illuminates when the warning message is displayed in the multi-information display.
	Multi Buzzer	Sounds when the warning message is displayed in the multi-information display.
Suspension Control ECU		Estimates the condition of the vehicle in accordance with the signals provided by the sensors and switches, and outputs control signals to the height control compressor assembly and No. 2 height control valve assembly.
Skid Control ECU		<ul style="list-style-type: none"> Sends the vehicle speed signal to the suspension control ECU. Sends the brake pedal depressing signal to the suspension control ECU.
Main Body ECU (Driver Side Junction Block Assembly)		<ul style="list-style-type: none"> Sends the open or closed status of the doors. Sends the open or closed status of the back door.
AFS ECU (Headlight Swivel ECU Assembly)		Calculates changes in the vehicle posture based on the signal from the suspension control ECU.

SYSTEM CONTROL

a. The rear air suspension system effects the following controls:

Control		Outline
Vehicle Height Control	Vehicle Height Switching Control	The driver can operate the height control switch to change the normal vehicle height position to the HI or LO vehicle height position as needed.
	Automatic Vehicle Height Control	Provides a function to keep a constant rear vehicle height regardless of the number of occupants or cargo.
	Vehicle Speed Sensing Control	When a vehicle height position other than Normal is selected and certain conditions have been met, the system automatically adjusts the position to the normal vehicle height in order to attain optimal levels of driving stability and ride comfort.
	Key Off Operation Control	For the purpose of making corrections such as when the rear vehicle height rises as a result of an occupant exiting the vehicle after the engine switch has been turned off, this function effects control to lower the vehicle even after the engine switch has been turned off.
	Vehicle Height Control Off	Vehicle height control can be halted by operating the height control OFF switch.
Suspension Control	Normal Control	Shuts off the right and left rear pneumatic cylinder assemblies by closing the gate solenoid valve in order to ensure the proper rolling rigidity and stable driving.
	Off-road Control	Connects the right and left rear pneumatic cylinder assemblies by opening the gate solenoid valve in order to ensure the proper driving performance on very bumpy roads.

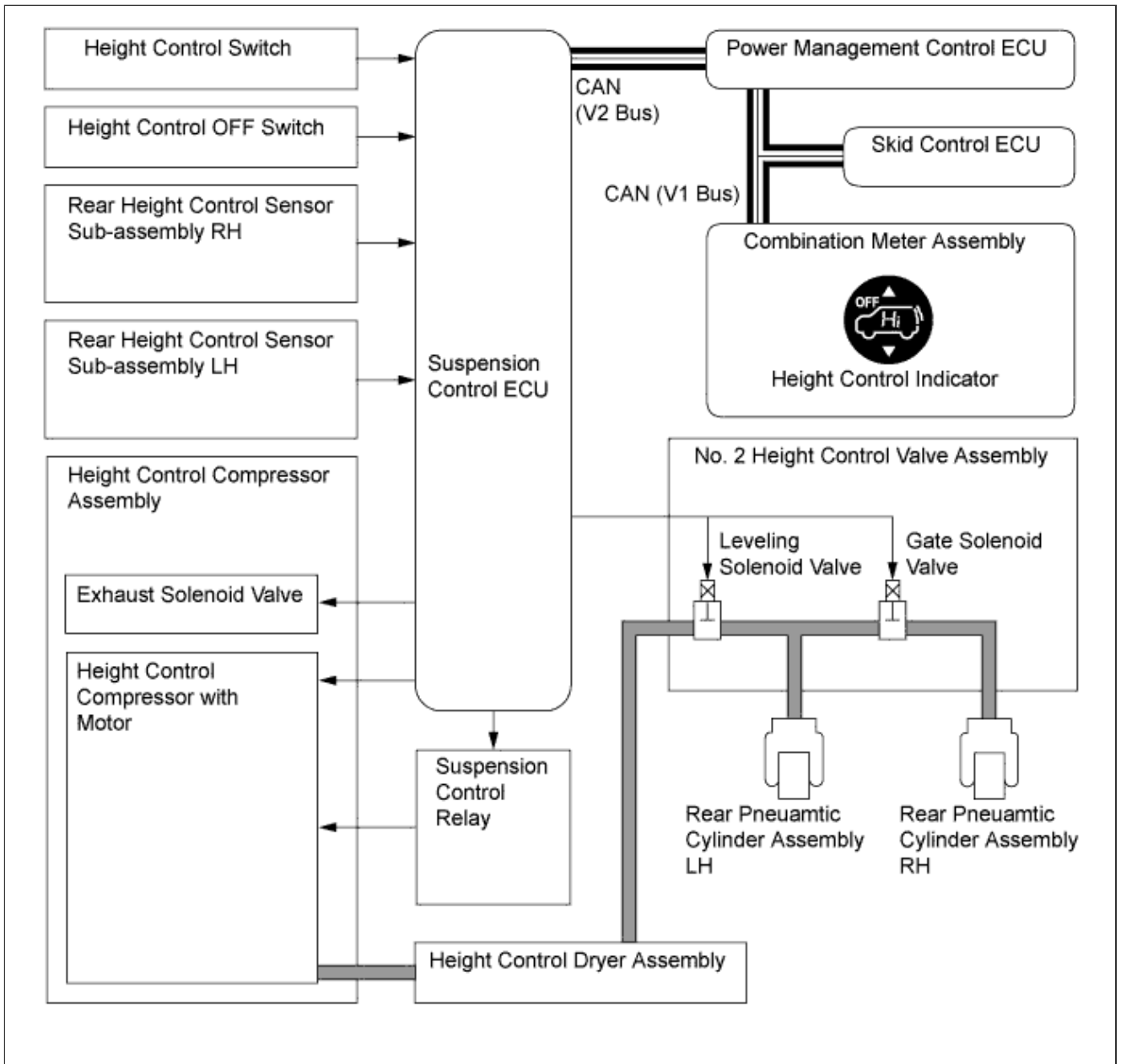

b. Vehicle Height Switching Control

- i. The driver can operate the height control switch to change the normal vehicle height to the HI or LO vehicle height as needed.
- ii. Upon detecting the changes in the vehicle height through the signals from the 2 rear height control sensor sub-assemblies, the suspension control ECU blinks the height control indicator in the combination meter assembly while the vehicle height is being adjusted, and illuminates it after the operation has been completed.

Vehicle Height Range

Vehicle Height Position	Difference in Height	
	Models for Europe	Except Models for Europe
HI	+ 30.0 mm (+ 1.2 in.)	+ 40.0 mm (+ 1.6 in.)
Normal	0	←

c. Automatic Vehicle Height Control

- i.** The suspension control ECU detects the changes in the rear vehicle height that result from changes in the number of occupants or the amount of load via the 2 rear height control sensor sub-assemblies. Then, the suspension control ECU controls the No. 2 height control valve assembly and the height control compressor assembly in order to automatically adjust the rear vehicle height to a constant (Normal) vehicle height.
- ii.** If the vehicle height is lower than Normal, the suspension control ECU raises the vehicle height by turning on (open) the exhaust solenoid valve, leveling solenoid valve, gate solenoid valve, and actuating the height control compressor with motor. The exhaust solenoid valve remains on (open) for a prescribed length of time (between 0 and 1 seconds) in order to ensure the initial operation of the height control compressor with motor and then turns off (closed). This length of the time is changed by power supply (+B) voltage.
- iii.** If the vehicle height is higher than Normal, the suspension control ECU lowers the vehicle height by turning on (open) the exhaust solenoid valve, leveling solenoid valve, and gate solenoid valve, and by stopping the height control compressor with motor.

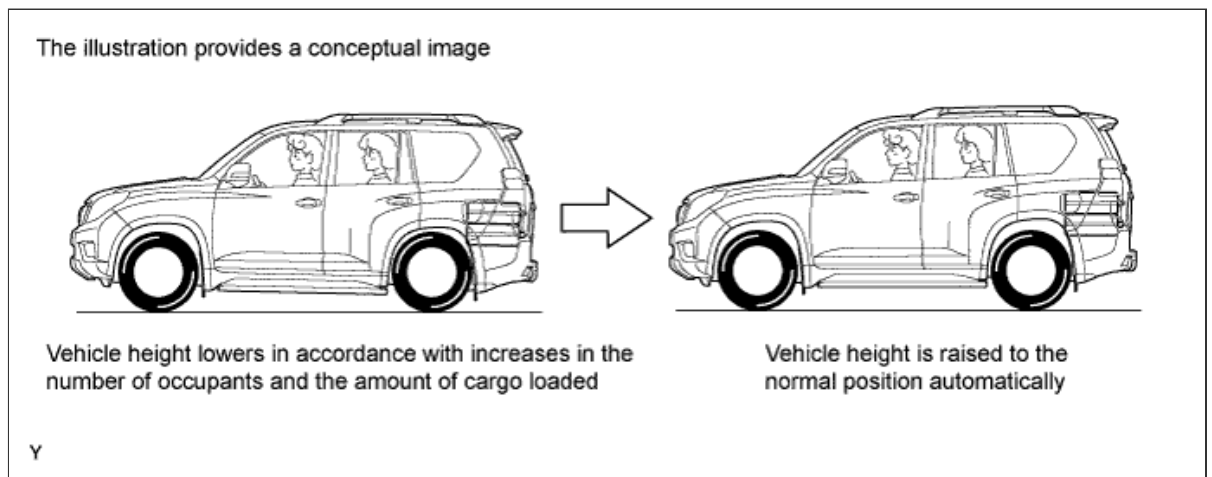
**d. Vehicle Speed Sensing Control**

- i.** The suspension control ECU detects the vehicle speed through the signals from the skid control ECU. When a vehicle height position other than Normal is selected and the conditions indicated in the table below have been met, the system automatically adjusts the position to the Normal vehicle height in order to attain optimal levels of driving stability and ride comfort. At this time, the suspension control ECU blinks the height control indicator and illuminates it after height control has been completed.
- ii.** Once the vehicle has been adjusted to the normal vehicle height through this control, it is not possible to select a vehicle height by operating the height control switch at a prescribed vehicle speed or below, unless the initial control is effected again.

Vehicle Speed Sensing Control

Vehicle Speed	Vehicle Height Position
More than 50 km/h (31 mph)	HI → Normal
More than 12 km/h (7 mph)	LO → Normal

e. Key Off Operation Control

- i. If the vehicle height increases after an occupant exits the vehicle or cargo is unloaded when the engine switch is off, this control causes the vehicle to resume the target vehicle height only for a prescribed length of time.
- ii. The suspension control ECU detects the off signal of the engine switch from the power management control ECU, the door open and closed signal from the main body ECU, and the vehicle height condition from the 2 rear height control sensor sub-assemblies, in order to effect the key off operation control as shown in the timing chart below.
- iii. There are 2 types of key off operation time depending on the vehicle height condition.

Key Off Operation Time

Vehicle Height Condition	Key Off Operation Time
No Change	Approx. 15 sec.
Change	Approx. 35 sec.

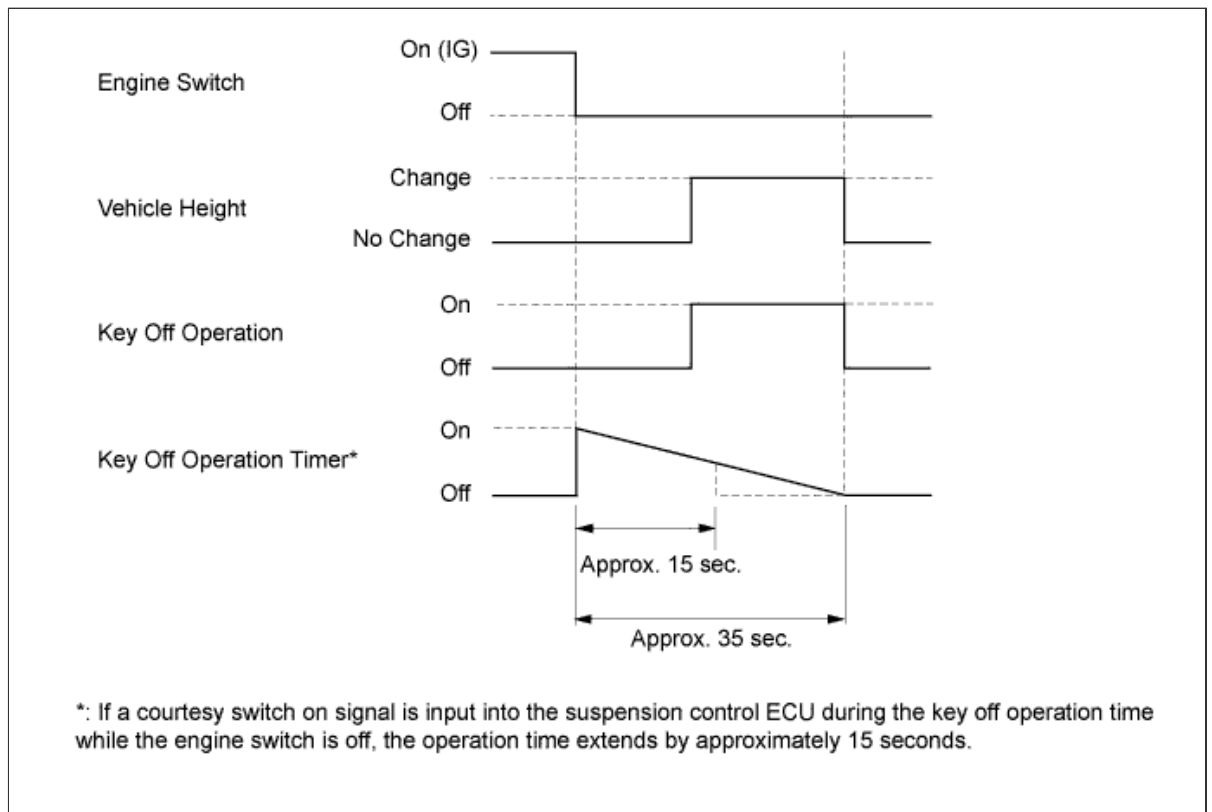

f. Vehicle Height Control Off

- i.** When the height control OFF switch is pressed, this control prohibits vehicle height control. This prevents unexpected changes in vehicle height or the inability of effecting normal control caused by raising the vehicle on a jack or hitching a trailer.
- ii.** The suspension control ECU illuminates the height control OFF indicator.
- iii.** When the vehicle is stopped, the vehicle height at the time the height control OFF switch was last pressed is preserved. However, vehicle speed sensing control is also implemented in order to maintain driving stability and ride comfort.

g. Suspension Control (Normal Control and Off-road Control)

- i.** The normal control turns off (closed) the gate solenoid valve during normal driving in order to increase the vehicle's rolling rigidity and ensure stability.
- ii.** Upon detecting the vehicle speed through the signals from the skid control ECU, and the vehicle height through the signals from the rear height control sensor sub-assemblies, the suspension control ECU turns off (closed) the gate solenoid valve in order to shut off the air path between the right and left rear pneumatic cylinder assemblies.

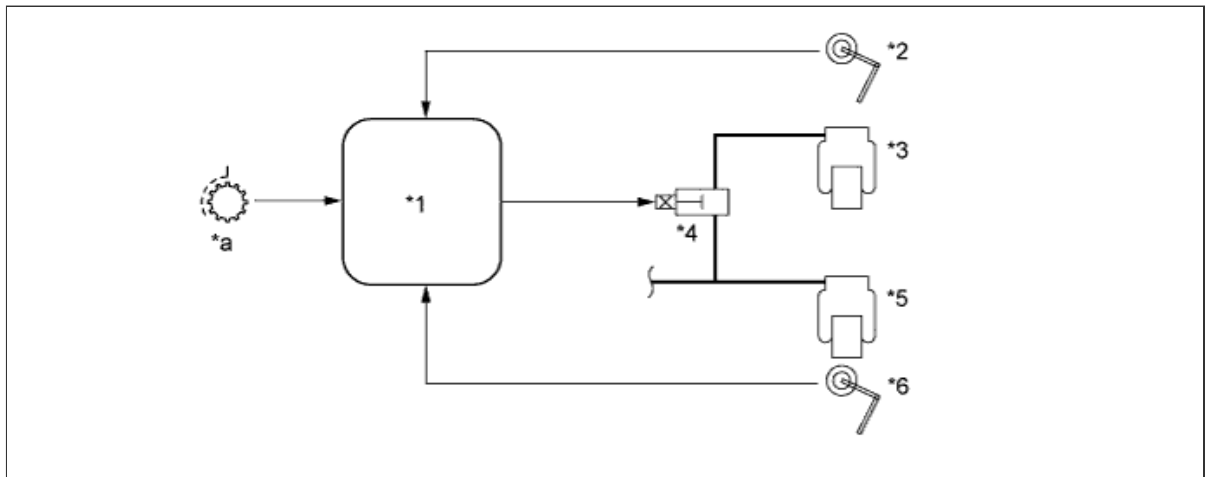

Text in Illustration

*1	Suspension Control ECU	*2	Rear Height Control Sensor Sub-assembly RH
*3	Rear Pneumatic Cylinder Assembly RH	*4	Gate Solenoid Valve (Closed)
*5	Rear Pneumatic Cylinder Assembly LH	*6	Rear Height Control Sensor Sub-assembly LH
*a	Vehicle Speed Signal	-	-

- iii.** The off-road control turns on (opens) the gate solenoid valve while the vehicle is being driven on bumpy roads at low speeds in order to ensure the proper driving performance.

- iv. The suspension control ECU determines when to start off-road control based on the height position signal and vehicle speed signal.
- v. The suspension control ECU starts off-road control when the vehicle speed is below 20 km/h (12 mph) and the vehicle height difference between the right and left sides is 100.0 mm (3.9 in.) or more.
- vi. When the off-road control starts, the gate solenoid valve opens, causing the rear roll rigidity to decrease. When the negative phase is input, the suspension stroke increases in order to enhance the grip of the tires, thus improving driving performance.
- vii. When the suspension control ECU detects a vehicle speed of 20 km/h (12 mph) or more, it closes the gate solenoid valve and cancels the off-road control.

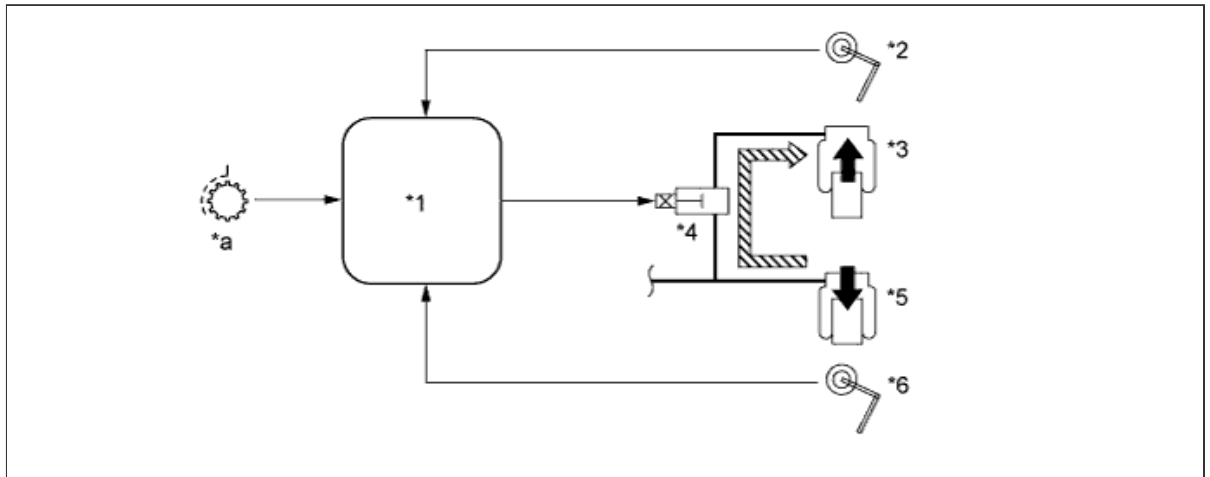

Text in Illustration

*1	Suspension Control ECU	*2	Rear Height Control Sensor Sub-assembly RH
*3	Rear Pneumatic Cylinder Assembly RH (Raise)	*4	Gate Solenoid Valve (Open)
*5	Rear Pneumatic Cylinder Assembly LH (Down)	*6	Rear Height Control Sensor Sub-assembly LH
*a	Vehicle Speed Signal	-	-
	Air Flow	-	-

CONSTRUCTION

a. Height Control Compressor Assembly

- i. The height control compressor assembly consists of a height control compressor with motor, a height control dryer assembly and an exhaust solenoid valve.
 - ii. The height control compressor with motor is used to make the compressed air necessary for raising the vehicle height.
 - iii. The height control dryer assembly is used to eliminate the moisture in the compressed air made by the height control compressor with motor.
 - iv. An exhaust solenoid valve is provided on the height control compressor with motor. The exhaust solenoid valve discharges compressed air from the rear pneumatic cylinder assemblies into the atmosphere in order to lower the vehicle height.
- v. To protect the battery, the height control compressor with motor operates only when the engine is running.

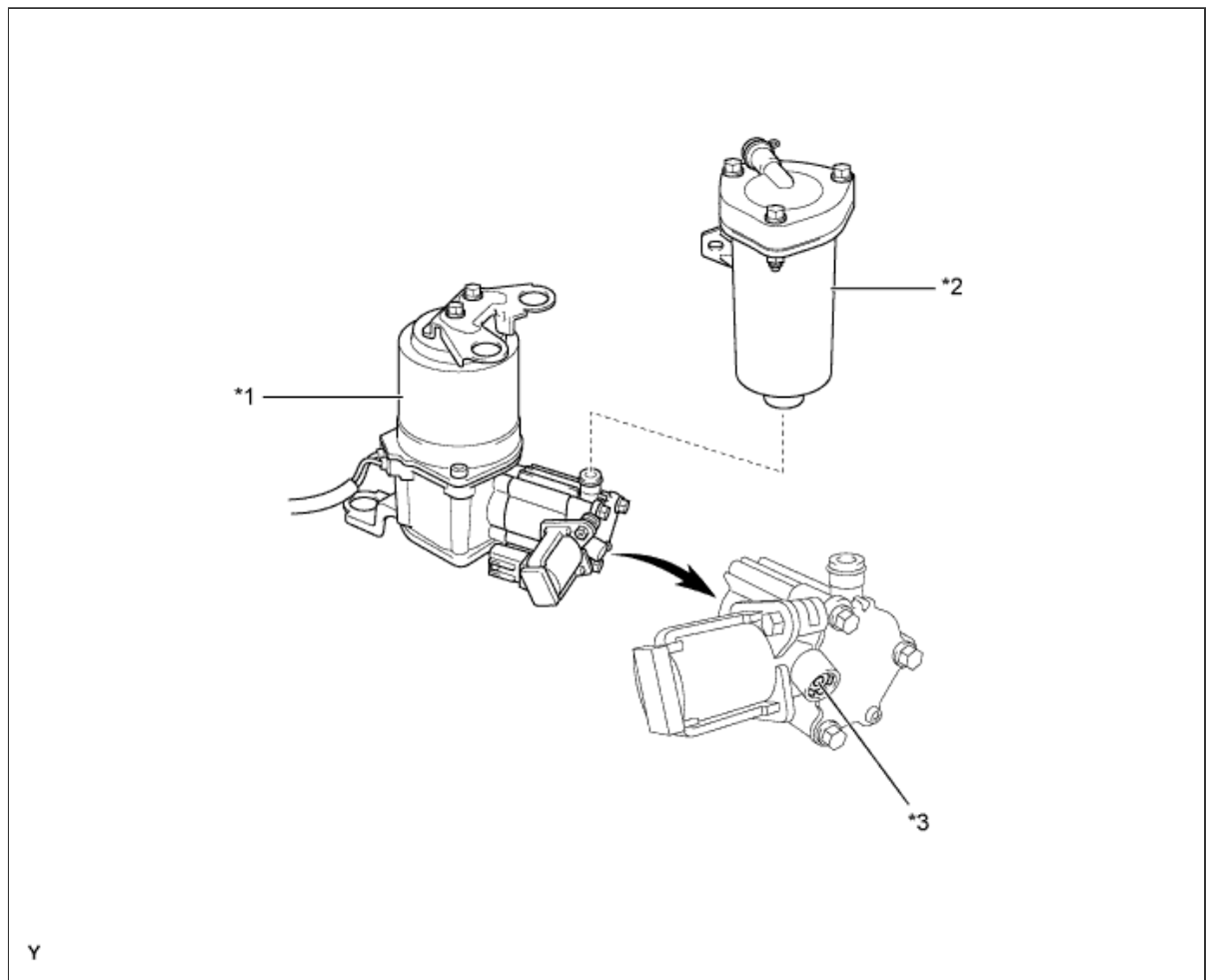

Text in Illustration

*1	Height Control Compressor with Motor	*2	Height Control Dryer Assembly
*3	Exhaust Solenoid Valve	-	-

b. Height Control Filter

- i.** The height control filter removes dust and debris, and has an expansion chamber to reduce the intake sound. In consideration of dusty areas, this filter draws air from the inside of the vehicle cabin.

- ii.** This cleaner cannot be disassembled. It is not possible to replace only the filter element.

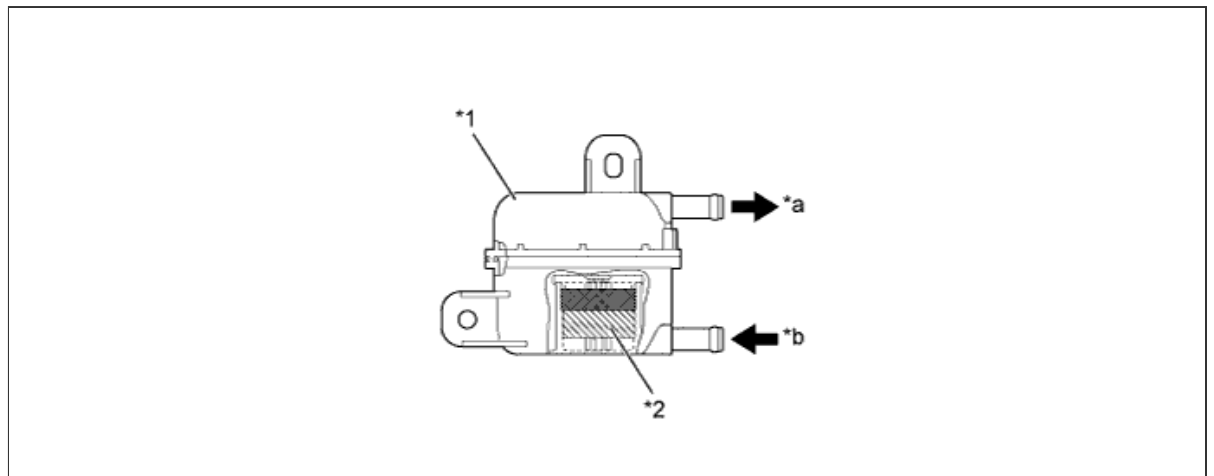

Text in Illustration

*1	Expansion Chamber	*2	Filter
*a	Out	*b	In

c. Rear Pneumatic Cylinder Assembly

- i.** The rear pneumatic cylinder assembly consists of a single type air chamber with a large compressed air capacity. Because of this, the assembly achieves excellent riding comfort.

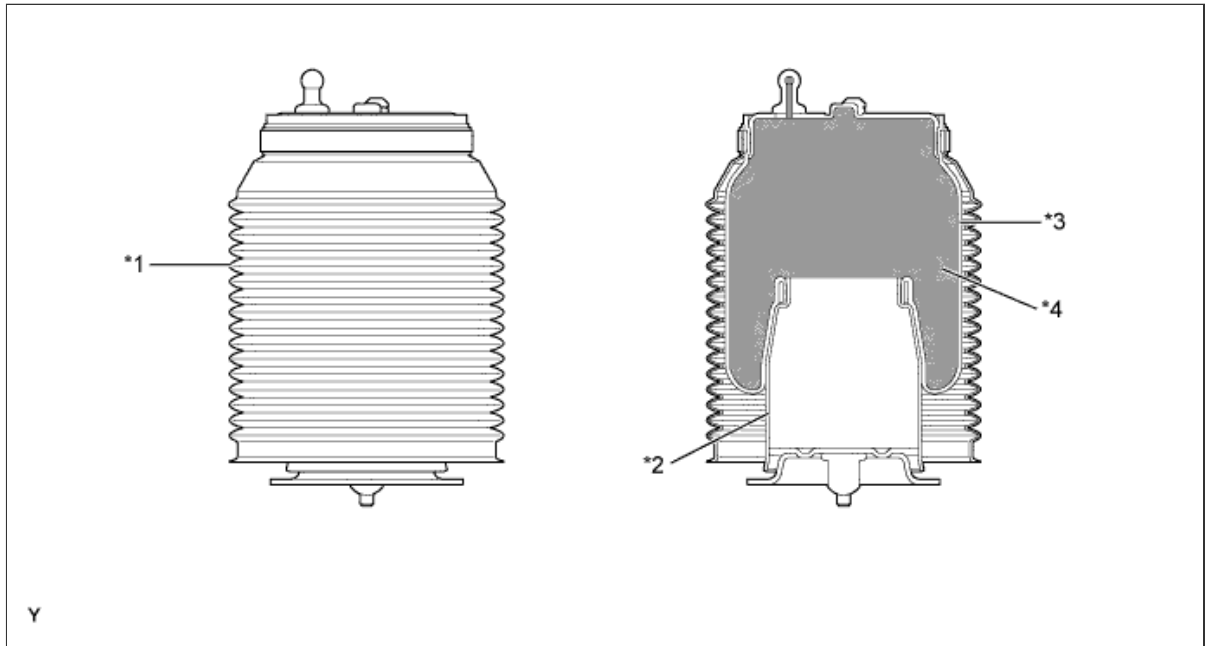

Text in Illustration

*1	Dust Cover	*2	Piston
*3	Diaphragm	*4	Chamber

d. No. 2 Height Control Valve Assembly

- i. The No. 2 height control valve assembly consists of a leveling solenoid valve and a gate solenoid valve.

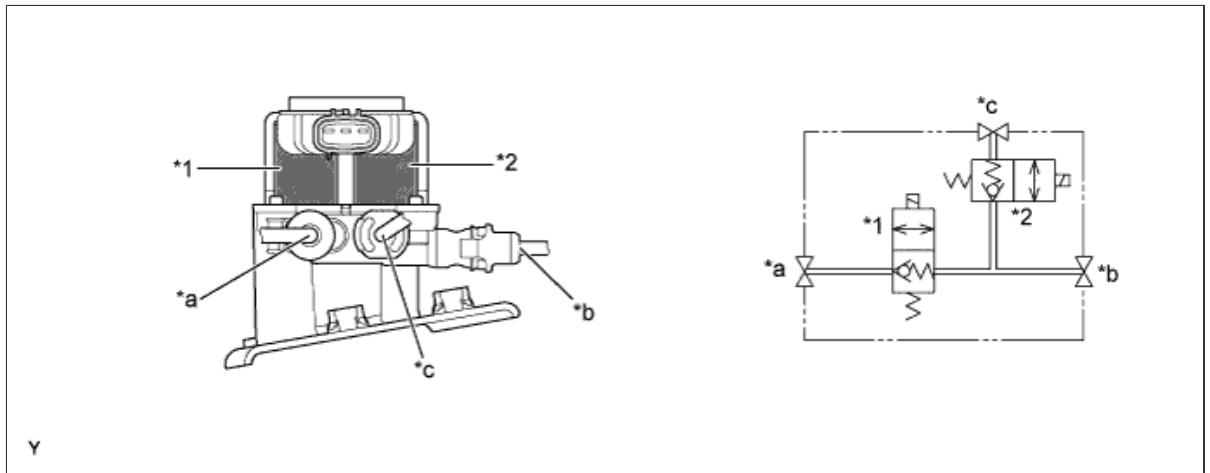

Text in Illustration

*1	Leveling Solenoid Valve	*2	Gate Solenoid Valve
*a	Port A (from Height Control Dryer Assembly)	*b	Port B (to Rear Pneumatic Cylinder Assembly RH)
*c	Port C (to Rear Pneumatic Cylinder Assembly LH)	-	-

e. Rear Height Control Sensor Sub-assembly

- i.** The rear height control sensor sub-assembly detects the vehicle height.
- ii.** The sensor has an arm that moves in accordance with changes in vehicle height, and the resultant change in voltage enables the suspension control ECU to detect the vehicle height.
- iii.** A semiconductor type of sensor is used to make the assembly compact and temperature-resistant.

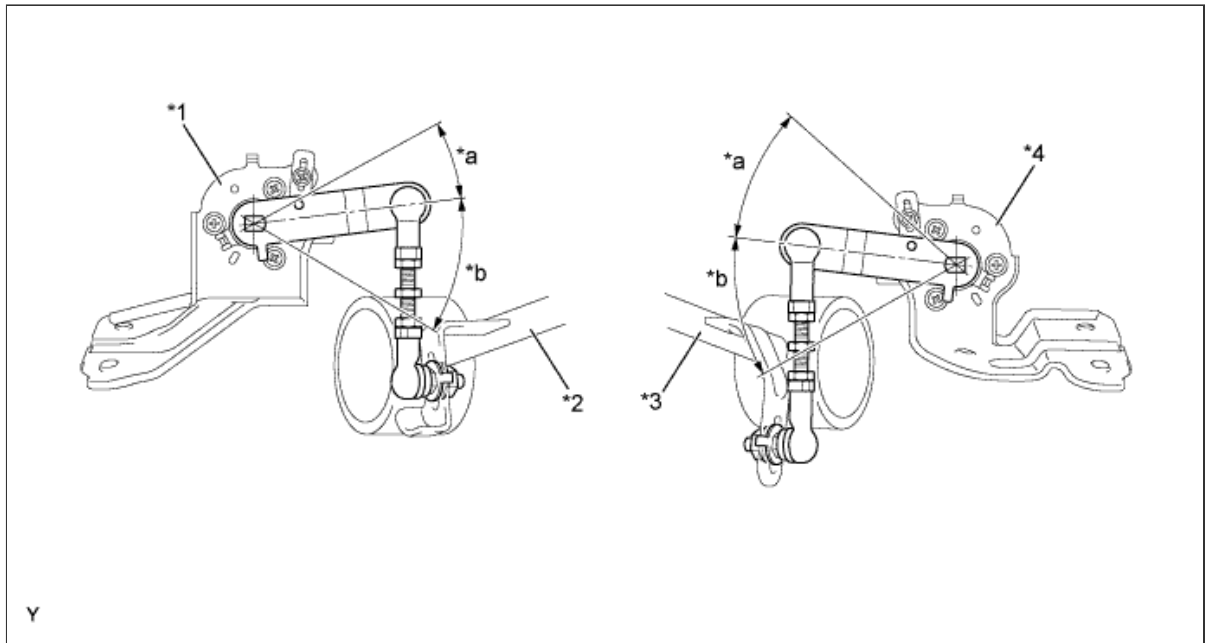

Text in Illustration

*1	Rear Height Control Sensor Sub-assembly LH	*2	Rear Upper Control Arm Assembly LH
*3	Rear Upper Control Arm Assembly RH	*4	Rear Height Control Sensor Sub-assembly RH
*a	Bound	*b	Rebound

- a. The suspension control ECU calculates the vehicle condition based on signals from each sensor and switch, and sets the appropriate vehicle height by controlling the height control compressor with motor and each solenoid valve.

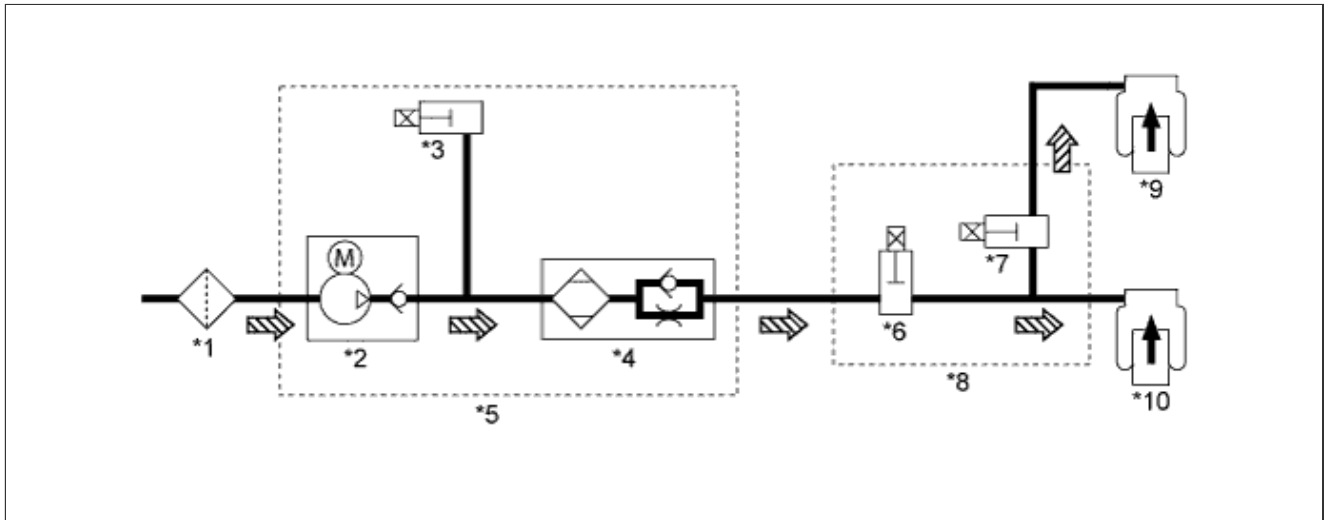

Text in Illustration (Raising Vehicle Height)

*1	Height Control Cleaner	*2	Compressor and Motor
*3	Exhaust Solenoid Valve (Open and Closed)	*4	Dryer
*5	Compressor and Motor with Dryer	*6	Leveling Solenoid Valve (Open)
*7	Gate Solenoid Valve (Open)	*8	No. 2 Height Control Valve Assembly
*9	Pneumatic Cylinder RH	*10	Pneumatic Cylinder LH
	Air Flow	-	-

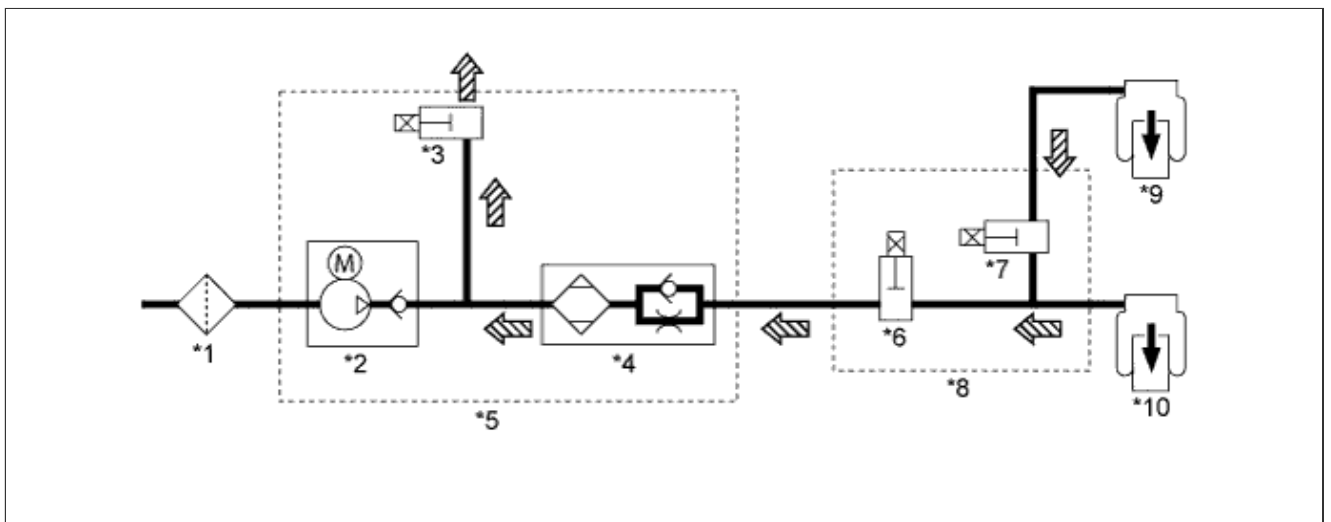

Text in Illustration (Lowering Vehicle Height)

*1	Height Control Cleaner	*2	Compressor and Motor
*3	Exhaust Solenoid Valve (Open and Closed)	*4	Dryer
*5	Compressor and Motor with Dryer	*6	Leveling Solenoid Valve (Open)
*7	Gate Solenoid Valve (Open)	*8	No. 2 Height Control Valve Assembly
*9	Pneumatic Cylinder RH	*10	Pneumatic Cylinder LH
	Air Flow	-	-

FAIL-SAFE

- a. If a malfunction occurs in the rear air suspension system, the suspension control ECU prohibits the vehicle height control.

DIAGNOSIS

- a. If the suspension control ECU detects a malfunction in the rear air suspension system, it displays a warning message on the multi-information display to alert the driver of the malfunction.
- b. The suspension control ECU will also store a Diagnostic Trouble Code (DTC). The DTC can be accessed through the use of an intelligent tester II. For details, refer to the corresponding Repair Manual for this model.

