

# POWER SOURCE LOCATION

6804F-02

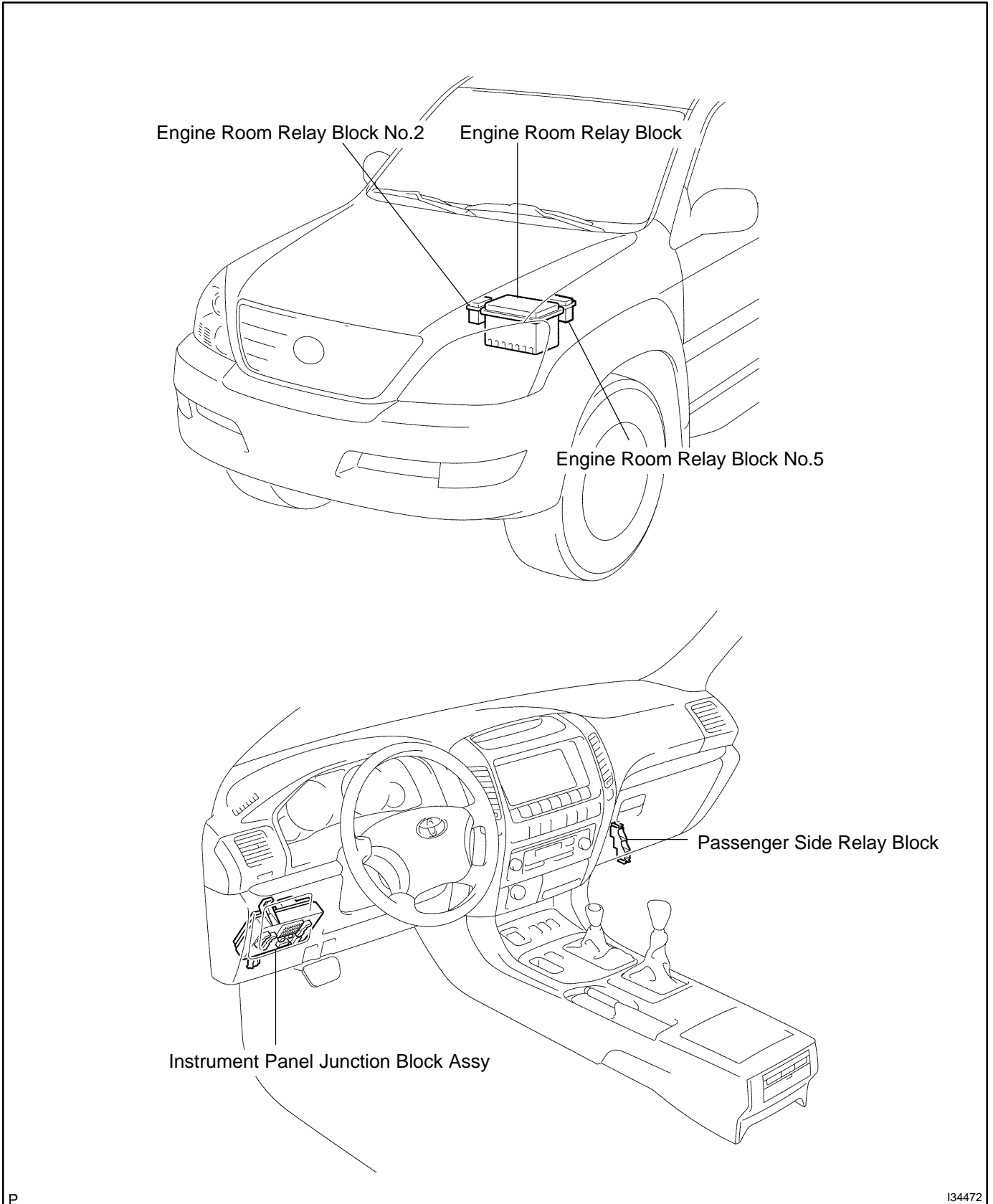

P

134472

## Engine Room Relay Block

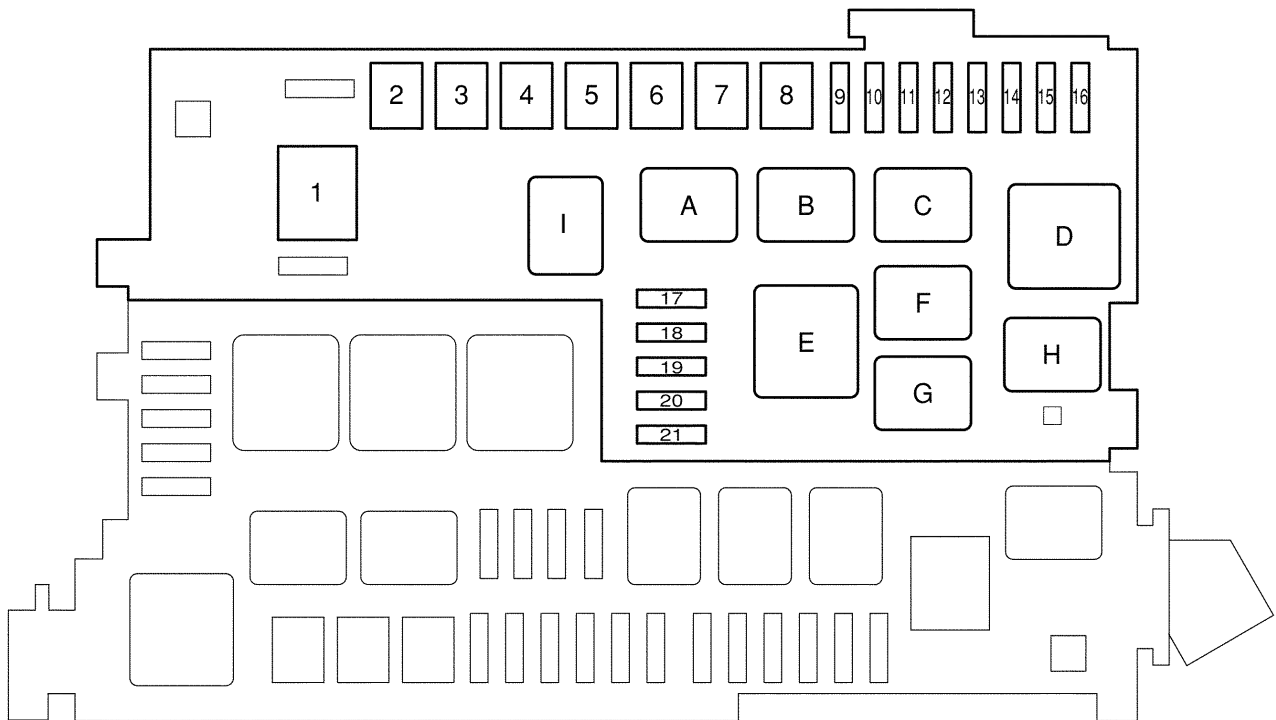
**RELAY****FUSE**

A. ACC CUT	1. ALT	140 A	12. STOP	10 A
B. FR FOG	2. HEATER	50 A	13. AC INV	15 A
C. STA	3. AIR SUS	50 A	14. FR FOG	15 A
D. IG	4. AM1	50 A	15. -	
E. HEATER	5. TOWING BRK	30 A	16. OBD	7.5 A
F. MG CLT	6. J/B	50 A	17. HEATER No.2	7.5 A
G. AC INV	7. BATT CHG	30 A	18. DEFOG	30 A
H. DEFOG	8. TOWING	40 A	19. AIR SUS No.2	10 A
I. CDS FAN	9. CDS FAN	20 A	20. -	
	10. RR A/C	30 A	21. SEAT HEATER	20 A
	11. MIR HEATER	10 A		

Engine Room Relay Block

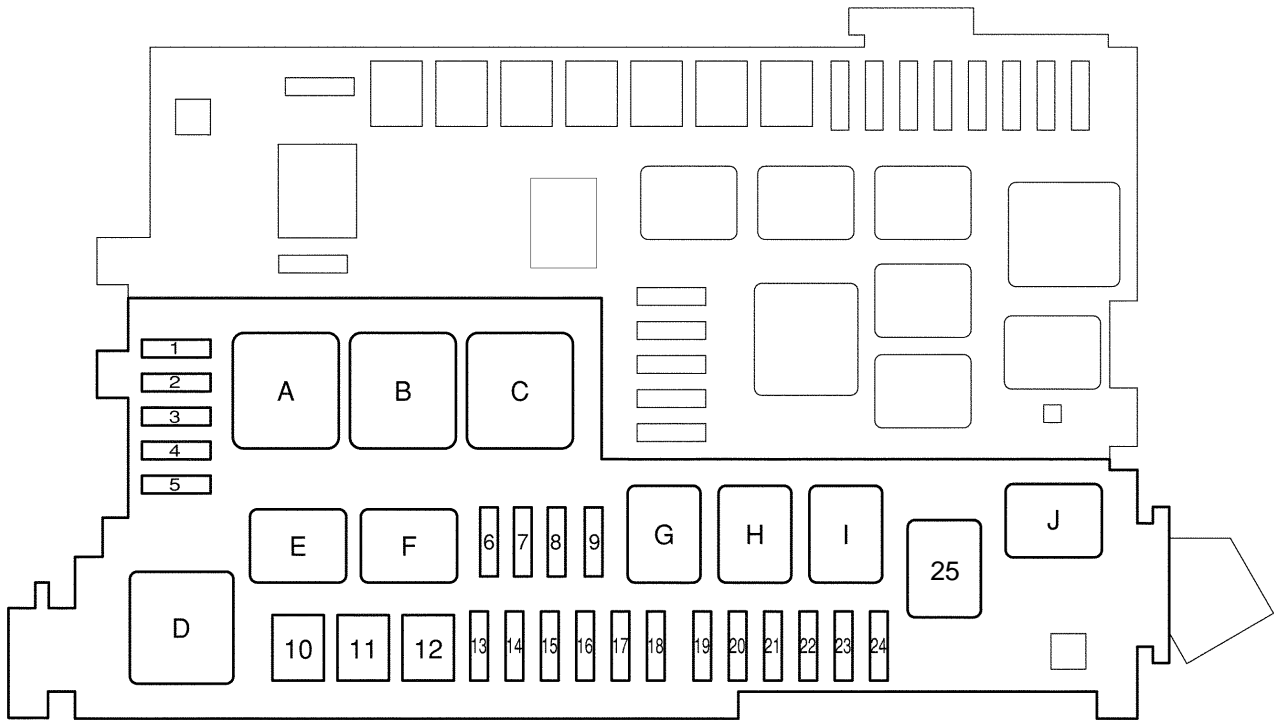

RELAY

FUSE

A. -	1. HEAD (LO RH) 10 A	13. SHORT PIN
B. -	2. HEAD (LO LH) 10 A	14. ALT-S 7.5 A
C. -	3. HEAD (HI RH) 10 A	15. MAYDAY 7.5 A
D. HEAD	4. HEAD (HI LH) 10 A	16. HORN 10 A
E. DAC	5. EFI No.2 10 A	17. A/F HEATER 15 A
F. C/OPN	6. DOME 10 A	18. TRN-HAZ 15 A
G. DOME	7. RADIO No.1 20 A	19. ETCS 10 A
H. EFI	8. ECU-B 10 A	20. EFI 20 A
I. A/F HEATER	9. ECU-B No.2 10 A	21. D FR P/W 20 A
J. FUEL PMP	10. ABS MTR 40 A	22. DR/LCK 25 A
	11. AM2 30 A	23. TOWING 30 A
	12. ABS SOL 30 A	24. RADIO No.2 30 A
		25. A/PUMP 50 A

## Instrument Panel Junction Block Assy

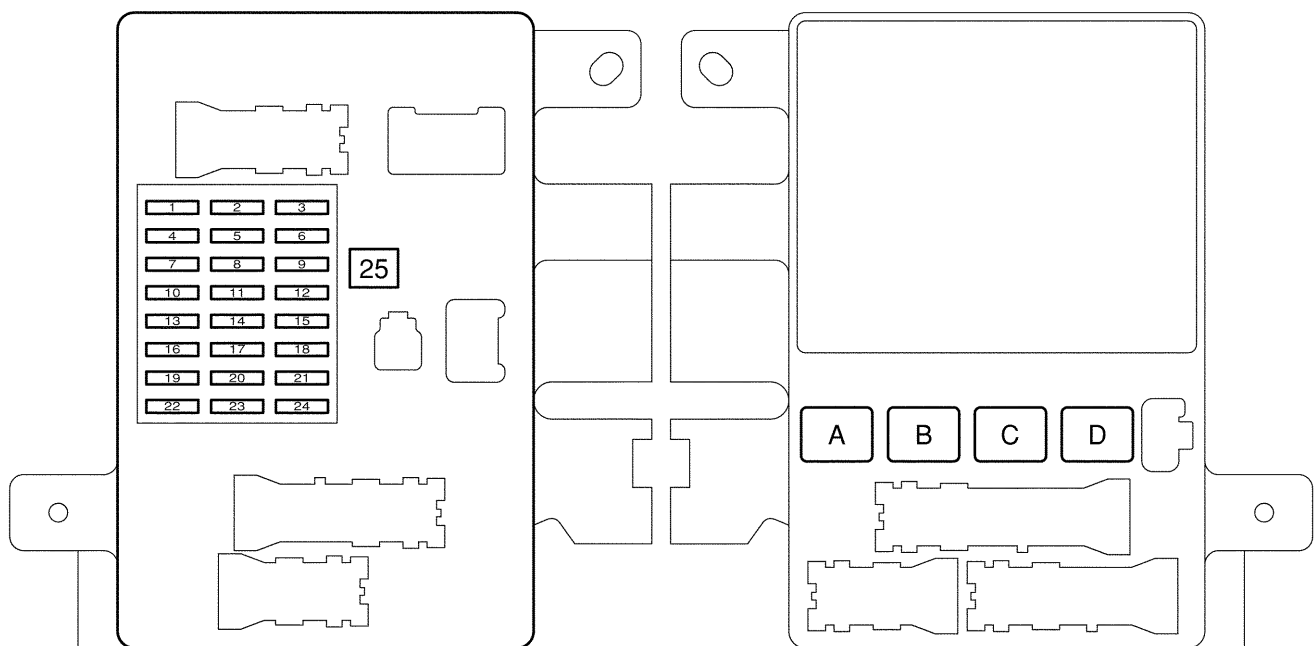
**RELAY**

- A. HORN
- B. TAIL
- C. POWER
- D. ACC SKT

**FUSE**

1. RR WIP	15 A	14. PWR OUTLET	15 A
2. IG 1	10 A	15. D RR P/W	20 A
3. CIG	10 A	16. GAUGE	7.5 A
4. DIFF	20 A	17. P P/SEAT	30 A
5. ECU-IG	10 A	18. P RR P/W	20 A
6. ACC	7.5 A	19. SRS	10 A
7. TEMS	20 A	20. D P/SEAT	30 A
8. RR WSH	15 A	21. P FR P/W	20 A
9. TAIL	10 A	22. IGN	10 A
10. FR WIP-WSH	30 A	23. -	
11. IG1 No.2	10 A	24. STA	7.5 A
12. PANEL	10 A	25. POWER or TI&TE	30 A
13. ST2	7.5 A		

**Engine Room Relay Block No.2**

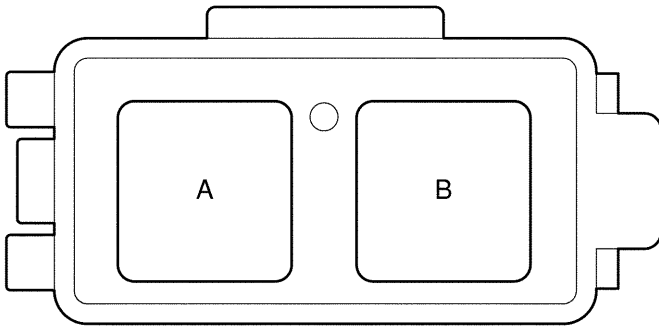

**RELAY**

- A. AIR SUS
- B. -

**Engine Room Relay Block No.5**

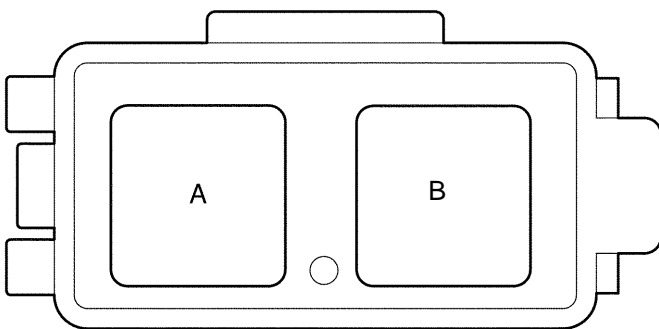

**RELAY**

- A. BATT CHG
- B. TOWING TAIL

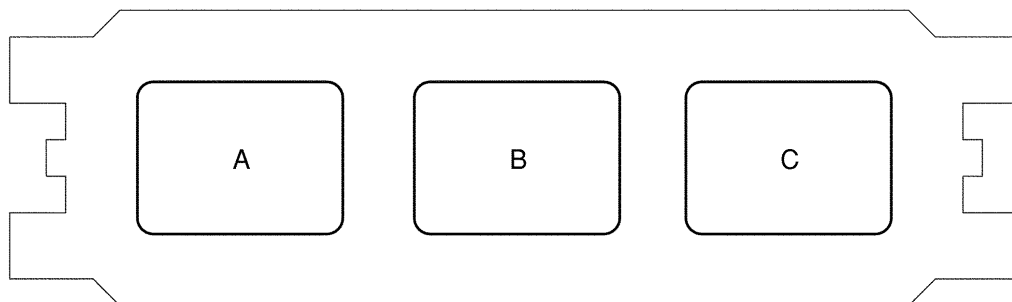
**Passenger Side Relay Block****RELAY**

- A. MIR HTR
- B. BK/UP LP
- C. -