

GENERAL MAINTENANCE

1. INSPECT STEERING LINKAGE & GEAR HOUSING

- (a) Check the steering wheel free play. **Appendix A**
- (b) Check the steering linkage for looseness or damage.
 - (1) Check that the tie rod ends do not have excessive play.
 - (2) Check that the dust seals and boots are not damaged.
 - (3) Check that the boot clamps are not loose.
 - (4) Check that the steering gear housing is not damaged.
 - (5) Check that the connectors are properly connected to the steering gear housing.

2. INSPECT STEERING GEAR HOUSING OIL

- (a) Check the steering gear housing oil leakage.
If leakage is found, check and repair the cause.

3. INSPECT BALL JOINT AND DUST COVER

- (a) Inspect the ball joints for excessive looseness.
 - (1) Jack up the front of the vehicle and place wooden blocks with a height of 180 to 200 mm (7.09 to 7.87 in.) under the front tires.
 - (2) Lower the vehicle until the front coil spring has about half its ordinary load. Place stands under the vehicle for safety.
 - (3) Check that the front wheels are pointing straight ahead. Use wheel chocks on all 4 wheels.
 - (4) Using a lever, pry up the end of the lower arm. Check the amount of play.

Maximum ball joint vertical play:
0 mm (0 in.)

If there is any play, replace the ball joint.

- (b) Check the dust cover for damage.

4. INSPECT DRIVE SHAFT BOOTS

- (a) Check the drive shaft boots for loose clamps, grease leakage, kinks or damage.

5. CHECK AUTOMATIC TRANSMISSION FLUID

- (a) Visually check the transmission for fluid leakage. If oil is leaking, find the cause and repair it.

Appendix B

6. INSPECT TRANSFER OIL

- (a) Visually check the transfer for oil leakage. If oil is leaking, find the cause and repair it. **Appendix C**

7. INSPECT FRONT DIFFERENTIAL OIL SEAL

8. INSPECT REAR DIFFERENTIAL OIL

Appendix D

9. REPACK FRONT WHEEL BEARINGS AND DRIVE SHAFT BUSHING GREASE

(a) Change the front wheel bearing grease.

(b) Repack the drive shaft bushing grease.

10. INSPECT FRONT AND REAR SUSPENSION

11. LUBRICATE PROPELLER SHAFT AND TIGHTEN BOLTS

(a) Lubricate propeller shaft, referring to the lubrication chart. Before pumping in grease, wipe off any mud and dust on the grease fitting.

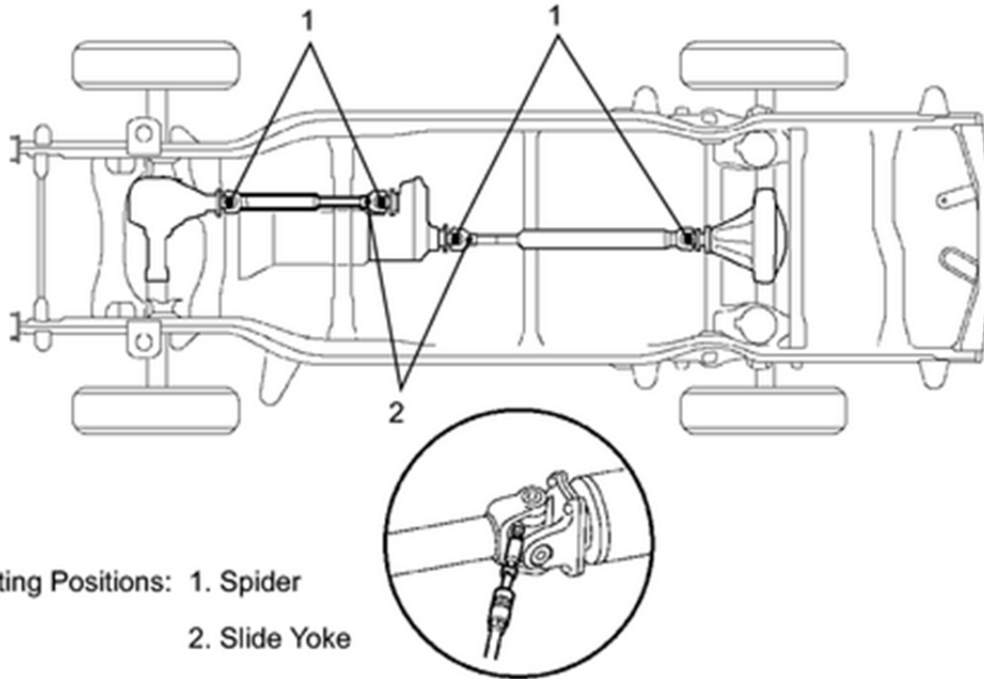

Lubricating Positions: 1. Spider
2. Slide Yoke

Y

Grease grade:

Lithium base chassis grease (NLGI No. 2)

(b) Tighten the bolts for propeller shaft.

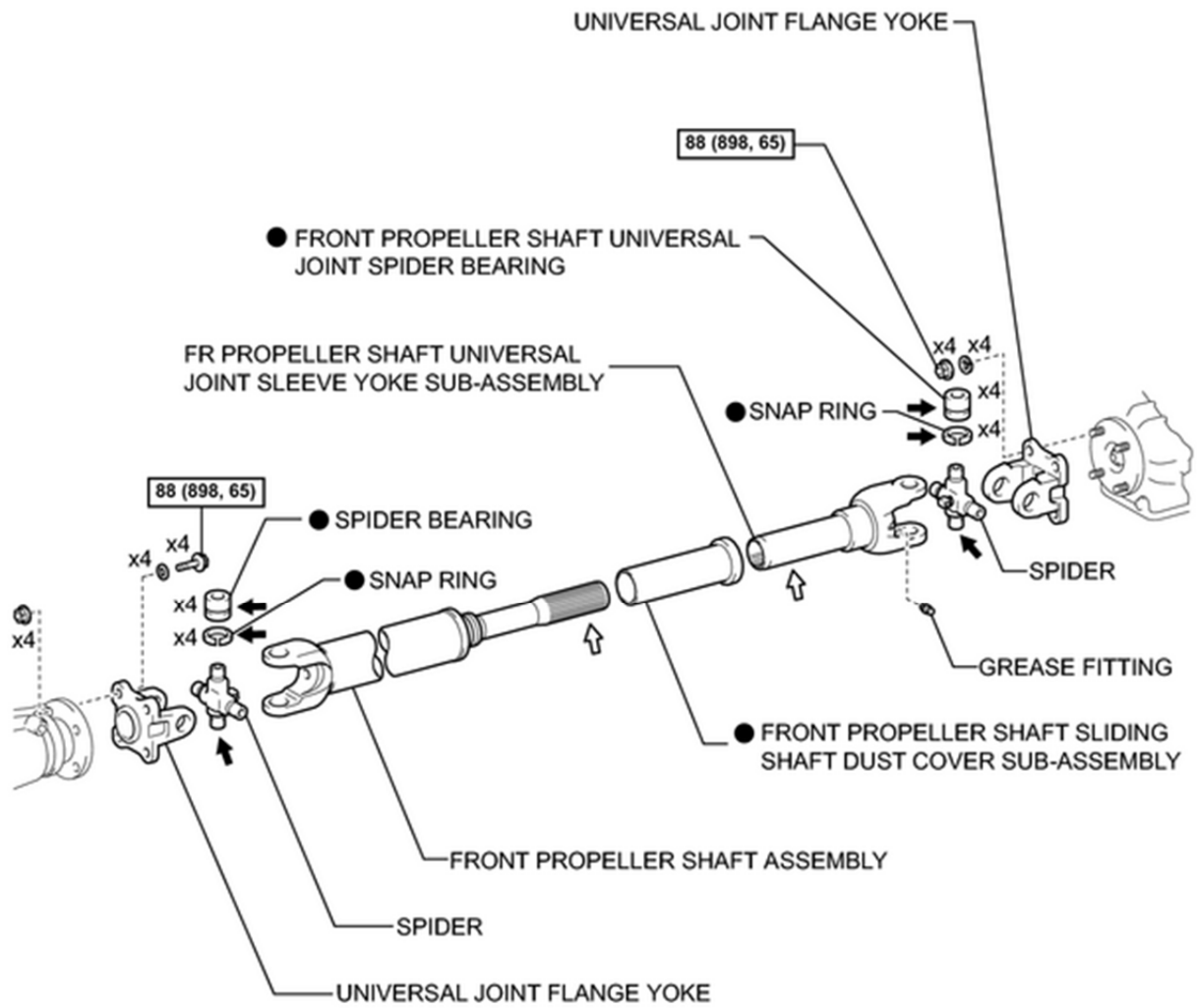

N*m (kgf*cm, ft.*lbf) : Specified torque

- Non-reusable part
- ↔ MP grease
- ← MP grease No. 2

P

Note: 65lb/ft

Appendix A

ON-VEHICLE INSPECTION

1. INSPECT STEERING WHEEL FREE PLAY

- (a) Stop the vehicle and align the tires facing straight ahead.
- (b) Gently turn the steering wheel right and left by hand, and check the steering wheel free play.

Maximum free play:
30 mm (1.18 in.)

HINT:

If the free play exceeds the maximum, check the steering column, steering intermediate shaft, steering sliding yoke, or steering gear.

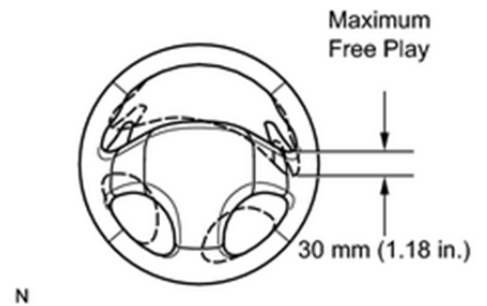

Appendix B

ADJUSTMENT

1. BEFORE FILLING TRANSMISSION

- This transmission requires Toyota Genuine ATF WS.
- It is necessary to refill the transmission with the correct amount of fluid.
- The vehicle must remain level while adjusting the transmission fluid level.
- On vehicles equipped with active suspension, turn the suspension control switch OFF if it is necessary to jack up the vehicle with the engine running. **Mine Is Equipped**

2. TRANSMISSION PAN FILL

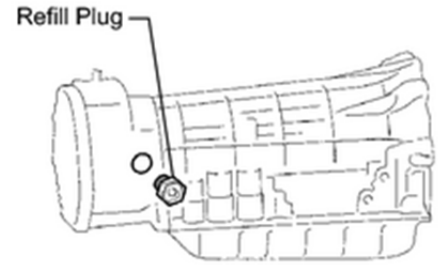

(a) Remove the refill plug and overflow plug.

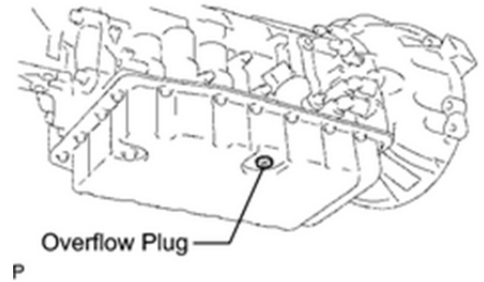

(b) Fill the transmission through the refill hole until fluid begins to trickle out of the overflow tube.

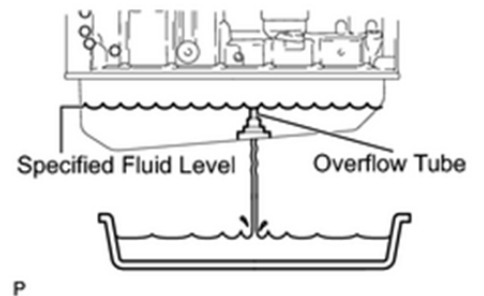

(c) Reinstall the overflow plug.

3. TRANSMISSION FILL

(a) Fill the transmission with the correct amount of fluid as listed in the table below.

(b) Reinstall the refill plug to avoid fluid splash.

REPAIR	FILL AMOUNT
Transmission pan and drain plug removal	1.7 liters (1.8 US qts, 1.5 Imp. qts)
Transmission valve body removal	4.3 liters (4.5 US qts, 3.8 Imp. qts)
Torque converter removal	5.4 liters (5.7 US qts, 4.8 Imp. qts)

HINT:

If you cannot add the listed amount of fluid, do the following:

- Install the refill plug.
- Allow the engine to idle with the air conditioning OFF.
- Move the shift lever through entire gear range to circulate fluid.
- Wait for 30 seconds with the engine idling.
- Stop the engine.
- Remove the refill plug and add fluid.
- Reinstall the refill plug.

4. FLUID CIRCULATION

(a) Allow the engine to idle with the air conditioning OFF.

(b) Move the shift lever through entire gear range to circulate fluid.

5. FLUID TEMPERATURE CHECK

At Dealership

6. FLUID LEVEL CHECK

NOTICE:

The fluid temperature must be between 36°C (97°F) and 46°C (115°F) to accurately check the fluid level.

(a) Remove the overflow plug with the engine idling.

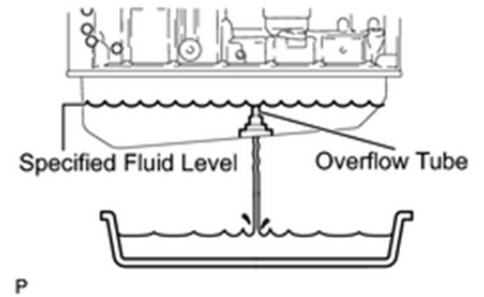

(b) Check that the fluid comes out of the overflow tube.

If fluid does not come out, proceed to step 7.

If fluid comes out, wait until the overflow slows to a trickle and proceed to step 8.

7. TRANSMISSION REFILL

(a) Install the overflow plug.

(b) Stop the engine.

(c) Remove the refill plug.

(d) Add 0.4 liters (0.42 US qts, 0.35 Imp qts) of fluid.

(e) Allow the engine to idle and wait for 10 seconds.

(f) Proceed to step 6.

8. COMPLETE

(a) Install the overflow plug with a new gasket.

(b) Stop the engine.

(c) Install the refill plug with a new gasket.

Torque:

Overflow plug -

20 N·m { 250 kgf·cm, 15ft·lbf }

Refill plug -

39 N·m { 400 kgf·cm, 29ft·lbf }

Appendix C

ADJUSTMENT

1. INSPECT TRANSFER OIL

- (a) Remove the case plug No. 1 (filler plug) and gasket.
- (b) Check that the oil level is within 5 mm (0.20 in.) of the bottom of the case plug No. 1 (filler plug) hole.

NOTICE:

- When replacing the oil, recheck the oil level after driving.
- Excessively large or small quantities of oil may cause troubles.

- (c) When the oil level is too low, check for oil leakage.
- (d) Tighten the case plug No. 1 (filler plug) with a new gasket.

Torque:

37 N·m { 377 kgf·cm, 27ft·lbf }

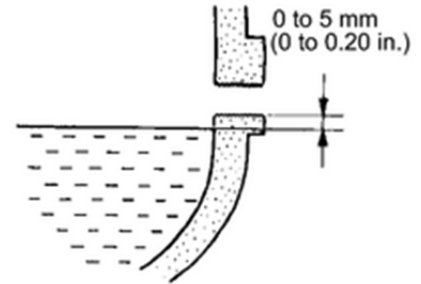

2. ADJUST TRANSFER OIL

- (a) Remove the case plug No. 1 (filler plug) and gasket then supply oil.

NOTICE:

- When supplying oil, pour slowly.
- Pour the oil in several stages allowing several minutes between each step.

HINT:

The oil level should be within 5 mm (0.20 in.) of the bottom of the oil filler plug hole.

- Oil grade:
API GL-5
Viscosity:
SAE 75W-90
Capacity:
1.4 liters (1.5 US qts, 1.2 Imp.qts)

- (b) After leaving it alone for 5 minutes, check the oil level again.
- (c) Tighten the case plug No. 1 (filler plug) with a new gasket.

Torque:

37 N·m { 377 kgf·cm, 27ft·lbf }

Appendix D

ADJUSTMENT

1. INSPECT DIFFERENTIAL OIL

(a) Stop the vehicle on a level place.

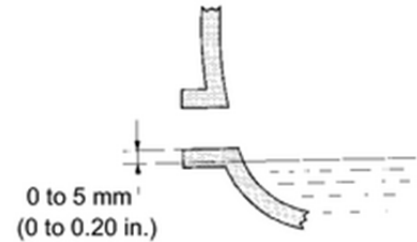

(b) Remove the differential filler plug and gasket.

(c) Check that the oil level is within 5mm (0 to 0.20 in.) of the bottom of the filler plug opening.

NOTICE:

- Excessively large or small quantities of oil may cause problems.
- After replacing the oil, drive the vehicle and check the oil level again.

HINT:

If necessary, fill the differential carrier assembly with hypoid gear oil.

Oil grade:

Hypoid gear oil API GL-5

Recommended viscosity:

Above -18°C (0°F) SAE 90

Below -18°C (0°F) SAE 80W or 80W-90

Capacity:

Front differential carrier assembly:

1.35 to 1.45 liters

(1.43 to 1.53 US qts, 1.19 to 1.27 Imp. qts)

Rear differential carrier assembly

3.00 to 3.10 liters

(3.17 to 3.27 US qts, 2.64 to 2.72 Imp. qts)

(d) Check for oil leakage if the oil level is low.

(e) Install the differential filler plug and a new gasket.

Torque:

Front differential carrier assembly -

39 N·m { 398 kgf·cm, 29ft·lbf }

Rear differential carrier assembly -

49 N·m { 500 kgf·cm, 36ft·lbf }