

Preparation

Part Number: Tuner Assy 86180-0W031
Mounting Kit 86100-0W080
86100-0W210 (with shark fin antenna)

※ Mounting kit 86100-0W080 is for standard audio and 86100-0W210 is for Mark Levinson Audio.

Tuner Assy Kit Contents (86180-0W031)

Item #	Quantity Req'd.	Description
1	1	TUNER ASSY, STEREO COMPONENT

Mounting Kit Contents (86100-0W080 or 86100-0W210)

Item #	Quantity Req'd.	Description
1	1	Wire, To Radio Installation
2	1	Antenna Cable
3	1	Tuner Cover
4	1	Bracket, Radio Receiver A
5	1	Bracket, Radio Receiver B

Mounting Kit Hardware Bag Contents 1 (86100-0W080 or 86100-0W210)

Item #	Quantity Req'd.	Description
1	6or7 ★	Cushion Tape (50mm×100mm)
2	6	Tie Wrap
3	1	Ground Cable

★ For the 86100-0W080: 6/ For 86100-0W210: 7

Mounting Kit Hardware Bag Contents 2 (86100-0W080 or 86100-0W210)

Item #	Quantity Req'd.	Description
1	4	Screw (M5×L8)
2	2	Turn Nut (M6)
3	2	Bolt (M6×L20)

Additional Items Required For Installation

Item #	Quantity Req'd.	Description

Conflicts

iPod Interface, Sirius Satellite Radio
--

Recommended Tools

Personal & Vehicle Protection	Notes
Vehicle Protection	Clean Cloths, Part Boxes
Special Tools	Notes
None	
Installation Tools	Notes
Wrench	Open End, 10mm

NOTE: Part number of this accessory may not be the same as the part number shown.

Socket	10mm
Screwdriver	Phillips, #2
Panel Clip Removal Tool	e.g. Toyota SST P/N:- 00002-06002-01
Utility Knife	
Side Cutter	
Torque Wrench	36 lbf · in
Special Chemicals	Notes
None	

General Applicability

--

Recommended Sequence of Application







Item #	Accessory

*Mandatory

Vehicle Service Parts (may be required for reassembly)

Item #	Quantity Req'd.	Description

Legend

	STOP: Damage to the vehicle may occur. Do not proceed until process has been complied with.
	OPERATOR SAFETY: Use caution to avoid risk of injury.
	CAUTION: A process that must be carefully observed in order to reduce the risk of damage to the accessory/vehicle.
	TOOLS & EQUIPMENT: Used in Figures calls out the specific tools and equipment recommended for this process.
	REVISION MARK: This mark highlights a change in installation with respect to previous issue.
	SAFETY TORQUE: This mark indicates that torque is related to safety.

Preparation

Parts Description of Tuner Assy (86180-0W030)

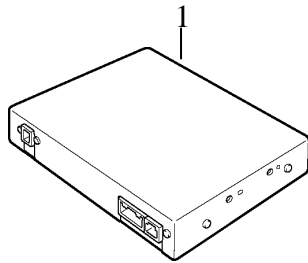

Item #	Parts Name	Parts No.	Qty
1	TUNER ASSY, STEREO COMPONENT ★	86180-0W030	1

★ In the installation instructions and figures, this is referred to as “Tuner”.

Parts Description of Mounting Kit (86100-0W080 or 86100-0W210)

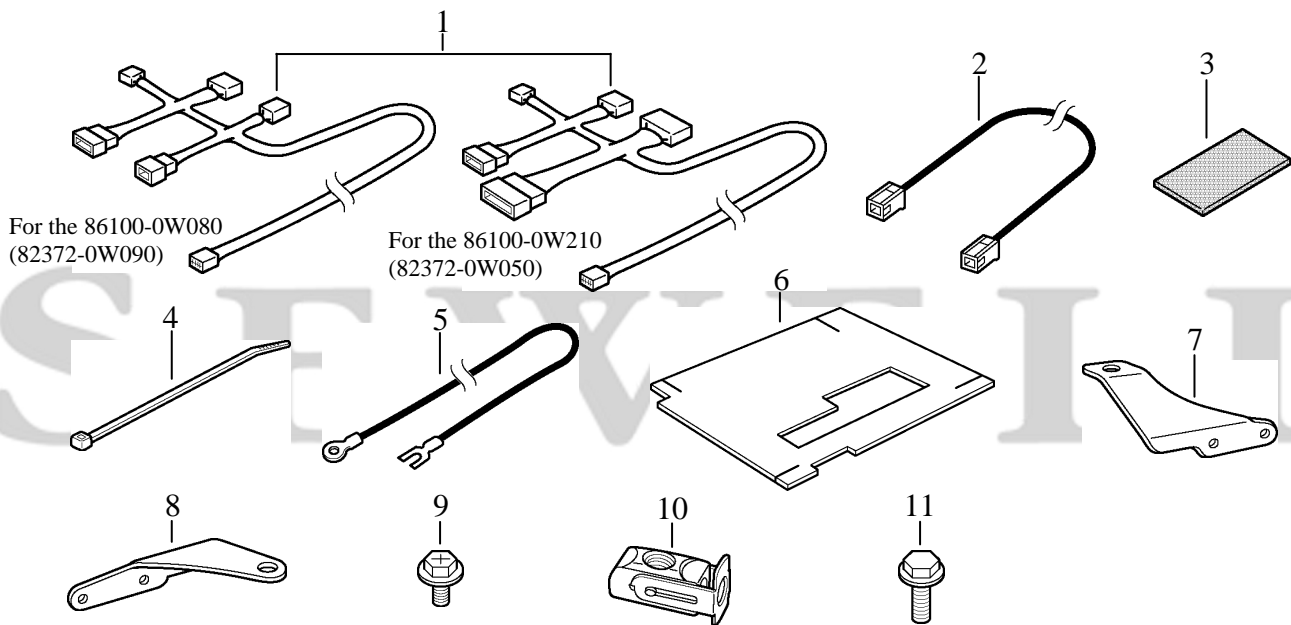

Item #	Parts Name	Parts No.	Qty
1	Wire, To Radio Installation ★1	82372-0W090 or 82372-0W050	1
2	Antenna Cable	—	1
3	Cushion Tape (50mm×100mm)	—	6or7 ★4
4	Tie Wrap	—	6
5	Ground Cable	—	1
6	Tuner Cover	—	1
7	Bracket, Radio Receiver A ★2	86215-0W110	1
8	Bracket, Radio Receiver B ★3	86215-0W120	1
9	Screw (M5×L8)	90153-50010	4
10	Turn Nut (M6)	—	2
11	Bolt (M6×L20)	91551-80620	2

★ 1 In the installation instructions and figures, this is referred to as “Tuner Cable”.

★ 2 In the installation instructions and figures, this is referred to as “Tuner Bracket A”.

★ 3 In the installation instructions and figures, this is referred to as “Tuner Bracket B”.

★ 4 For the 86100-0W080: 6/ For 86100-0W210: 7

Care must be taken when installing this accessory to ensure damage does not occur to the vehicle. The installation of this accessory should follow approved guidelines to ensure a quality installation.

These guidelines can be found in the "Accessory Installation Practices" document.

This document covers such items as:-

- Vehicle Protection (use of covers and blankets, cleaning chemicals, etc.).
- Safety (eye protection, rechecking torque procedure, etc.).
- Vehicle Disassembly/Reassembly (panel removal, part storage, etc.).
- Electrical Component Disassembly/Reassembly (battery disconnection, connector removal, etc.).

Please see your Lexus dealer for a copy of this document.

1. Vehicle Protection

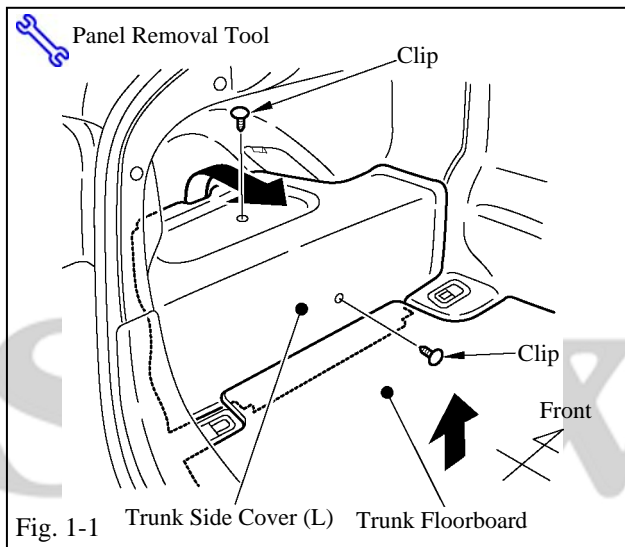

(a) Set emergency hand brake.

(b) Remove the negative battery cable.



(1) Protect the fender before starting.

(2) Remove the trunk floorboard (Fig. 1-1).

(3) Remove the trunk side cover (L)
(Fig. 1-1).

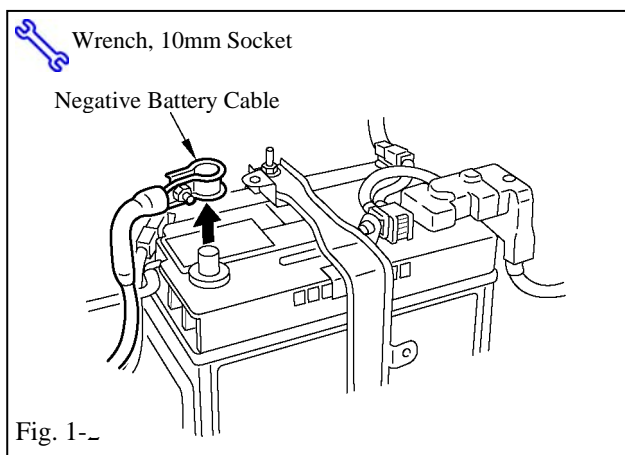

(4) Do not touch the positive terminal with any tool when removing cable (Fig. 1-2).

(c) Wait 90 seconds before proceeding to disassemble vehicle.

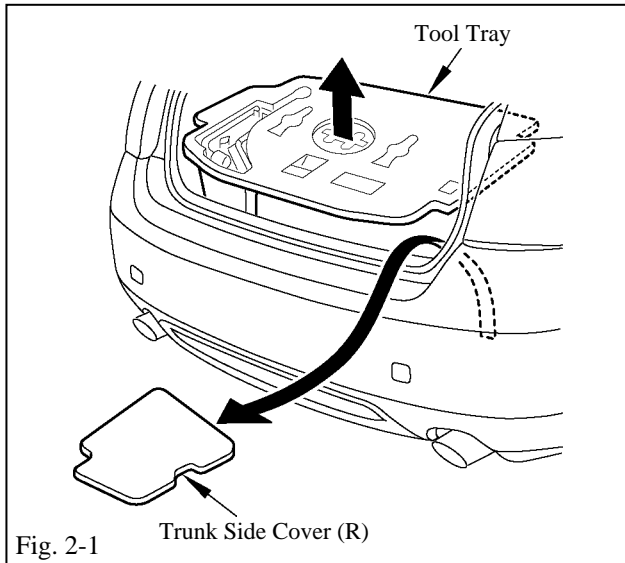

NOTE: Place all removed parts on a protected surface.



NOTE: When disconnecting wiring connectors do not pull on the wiring, pull on the connector only.

- (a) Remove the trunk side cover (R) (Fig. 2-1).
- (b) Remove the tool tray (Fig. 2-1).

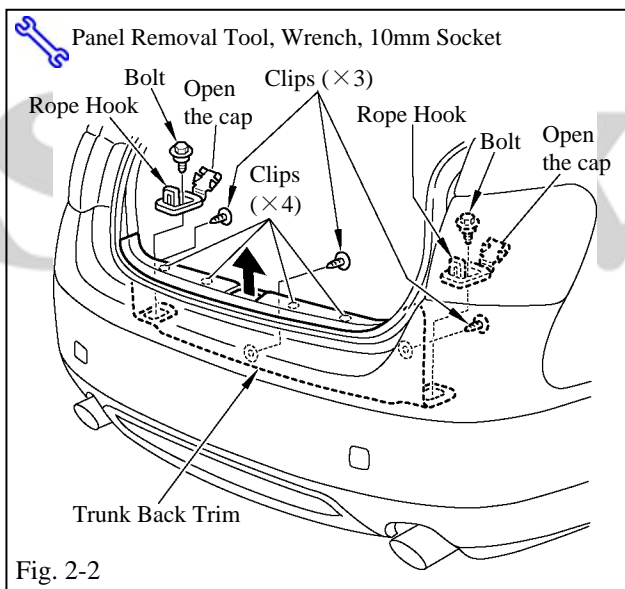

- (c) Remove the trunk back trim (Fig. 2-2).
 - (1) Remove the bolt, and then remove rope hooks.
 - (2) Remove clips.
 - (3) Pull the trim up and remove clips.

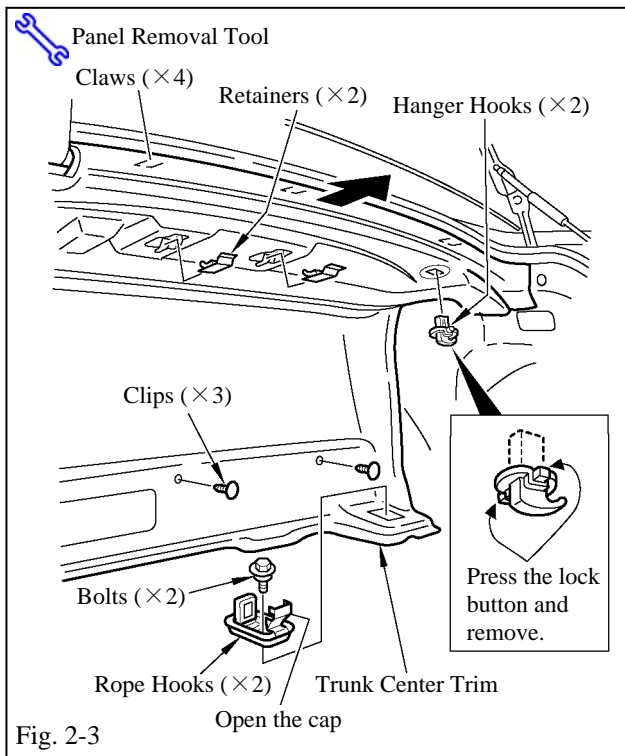

Fig. 2-3

(d) Remove the trunk center trim (Fig. 2-3).

NOTE: The right side is shown in the figure, but the procedure is the same for the left side.

- (1) Remove retainers from the upper section.
- (2) Remove hanger hooks from the upper section.
- (3) Remove the nut from the front section.
- (4) Remove clips from the floor section.
- (5) Pull the upper edge of the trim towards you, and remove claws.

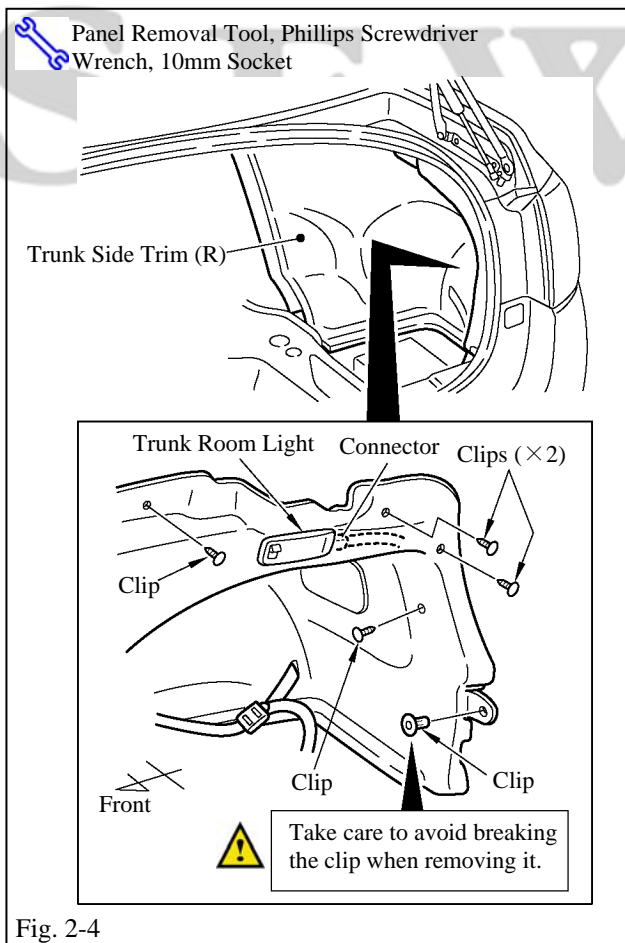

Fig. 2-4

(e) Remove the trunk side trim (R) (Fig 2-4).

- (1) Remove clips.
- (2) Pull the trim towards the inside, and disconnect the trunk room light connector.

3. Tuner Installation

- (a) Attach tuner brackets A, B and ground cable to the tuner (Fig. 3-1).

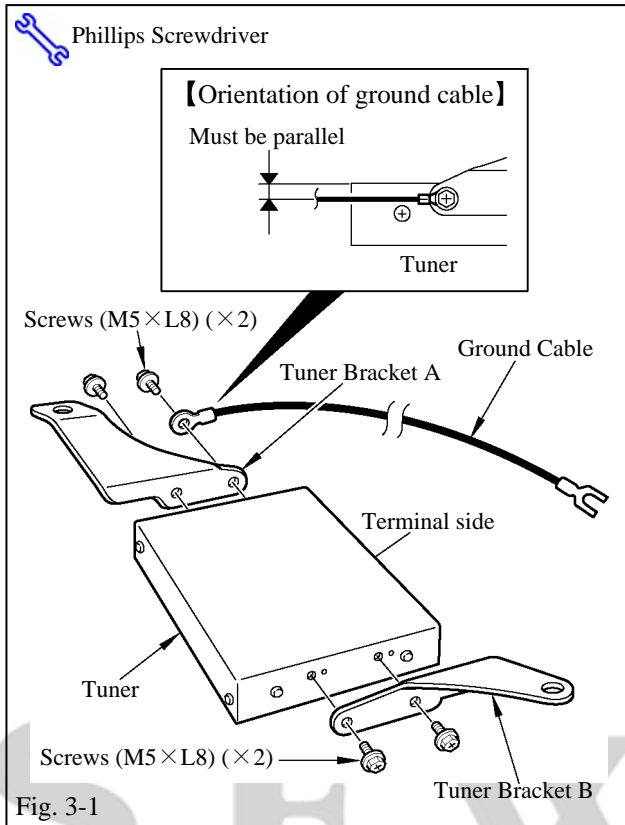

- (b) Attach the tuner cover to the tuner.
- (1) Bend the tuner cover inwards along the scored lines (Fig. 3-2).

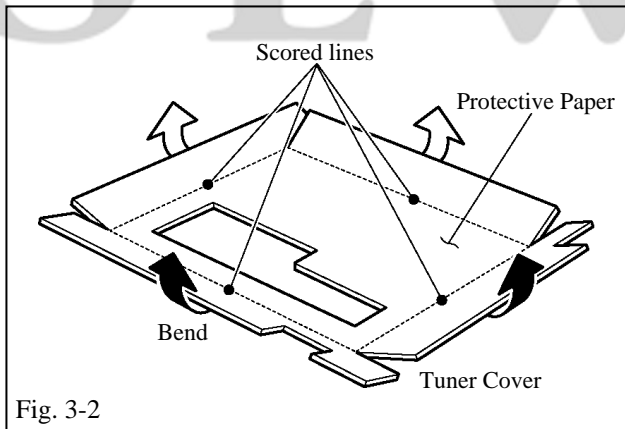

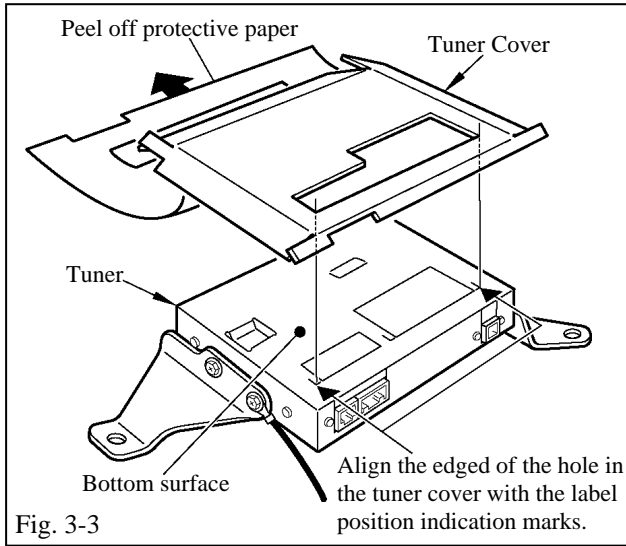

- (2) Peel off the protective paper from the tuner cover, and stick to the bottom surface (labeled surface) of the tuner (Fig. 3-3).

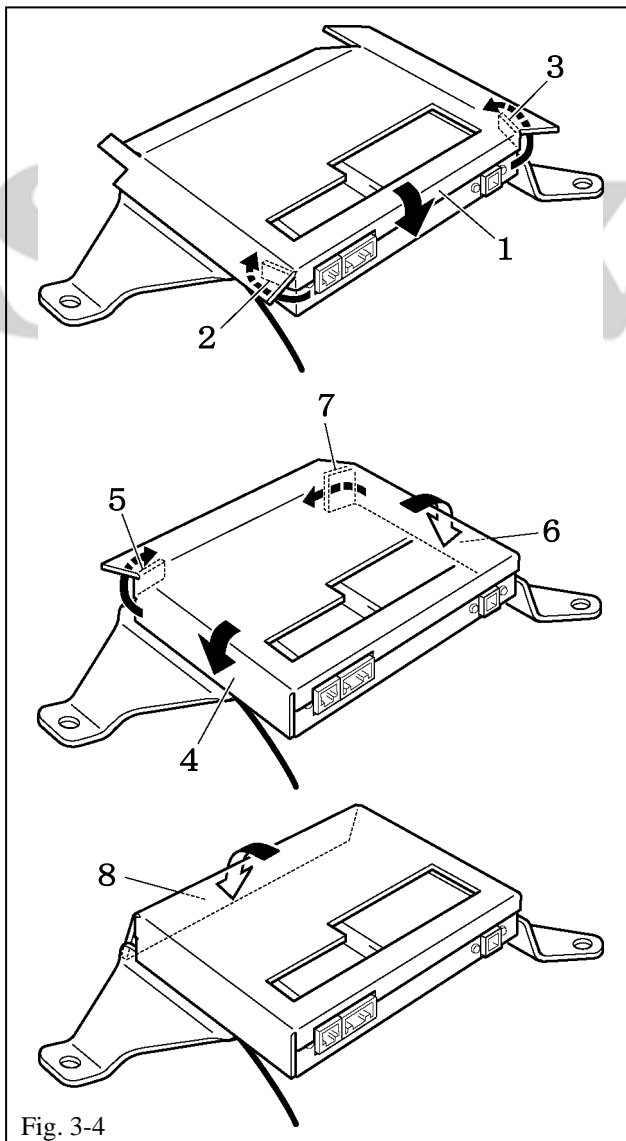

- (3) Stick the tuner cover to the sides of the tuner following procedures 1 through 8 indicated in the figure (Fig. 3-4).

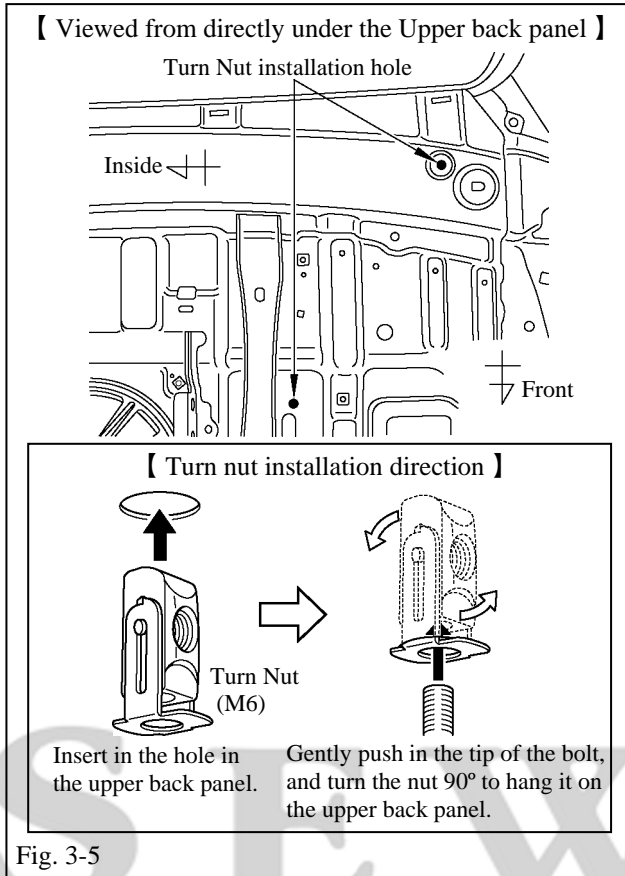

(c) Install the tuner on the upper back panel of the trunk room.

- (1) Install a turn nut in the upper back panel in the position indicated in the figure (Fig. 3-5).

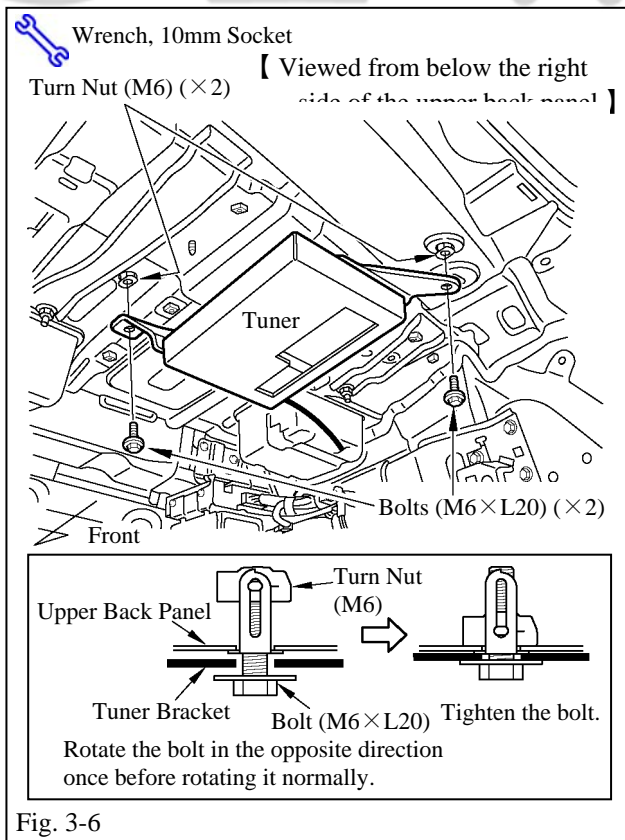

- (2) Secure the tuner to the turn nut with a bolt (Fig. 3-6).

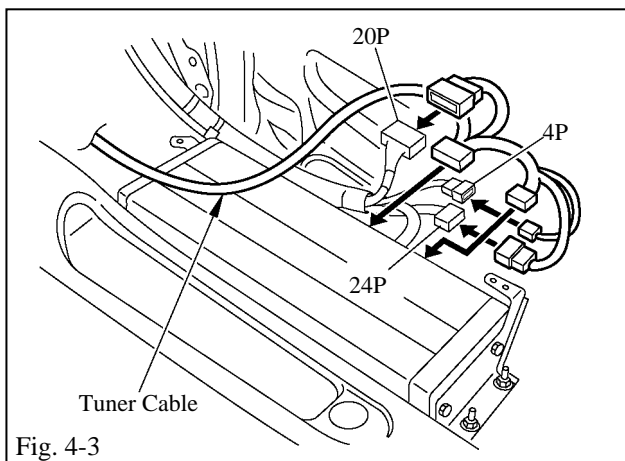
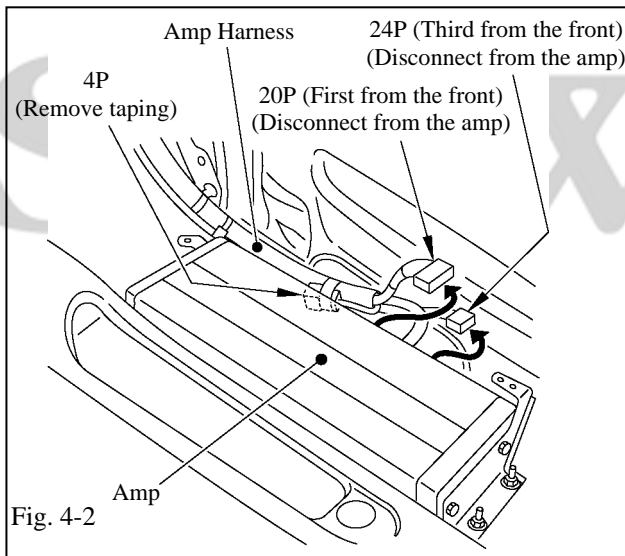
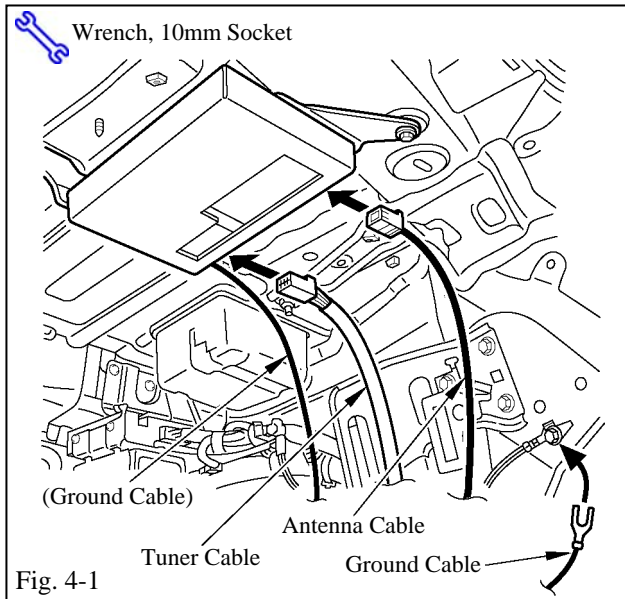

4. Tuner cable, antenna cable and ground cable wiring

- (a) Connect the tuner cable and antenna cable to the tuner (Fig. 4-1).
- (b) Secure the ground cable at the location indicated in the figure with the bolt (Fig. 4-1).

- (c) Remove the amp harness connectors (Fig. 4-2).

NOTE: If the Mark Levinson audio amp is used, remove 24P and 20P. With the standard audio amp, remove 24P and 6P.

- (d) Remove the 4P connector that is secured to the amp harness with tape (Fig. 4-2).

NOTE: The indications in the figure are for a Mark Levinson audio amp but they are the same for standard audio amps.

- (e) Connect the tuner cable connectors to the amp harness and the amp (Fig. 4-3).

NOTE: If the Mark Levinson audio amp is used, connect 24P and 20P. With the standard audio amp, connect 24P and 6P.

- (f) Connect the 4P tuner cable connector to the amp harness 4P connector (Fig. 4-3).

NOTE: The indications in the figure are for a Mark Levinson audio amp but they are the same for standard audio amps.

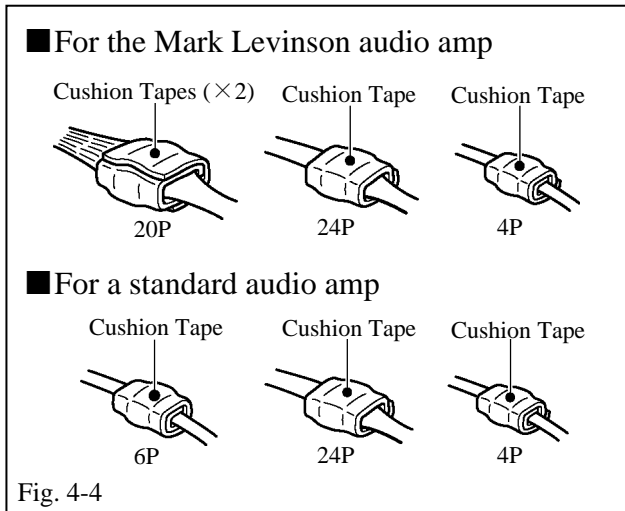

(g) Wrap cushion tape around locations where the connector is connected (Fig. 4-4).

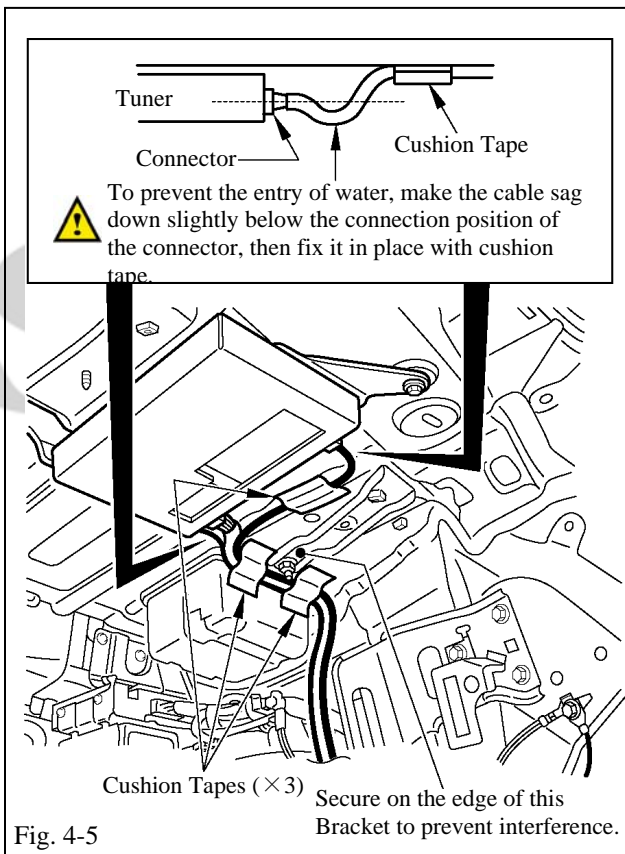

(h) Secure the tuner cable, antenna cable and ground cable to the upper back panel in the indicated locations using cushion tape (Fig. 4-5).

[For models not equipped with Lexus Link]

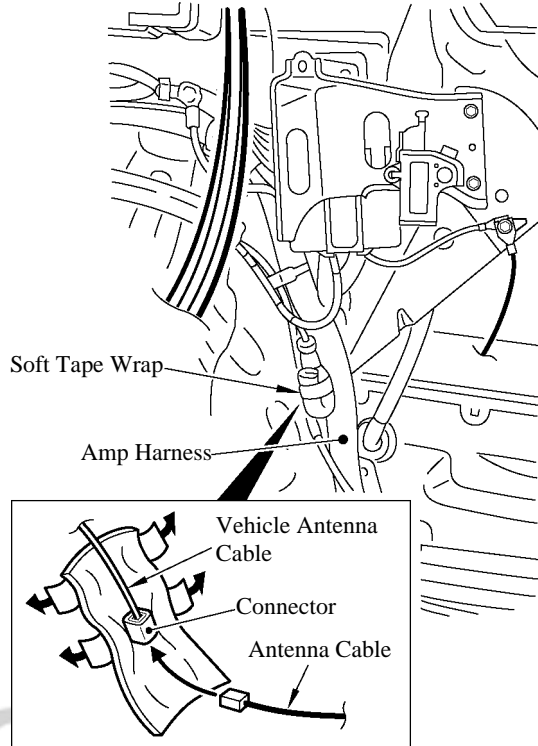

Fig. 4-6

[For models equipped with Lexus Link]

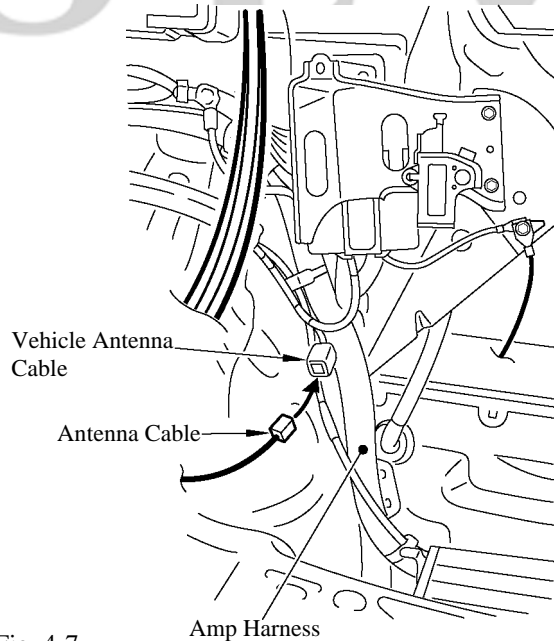
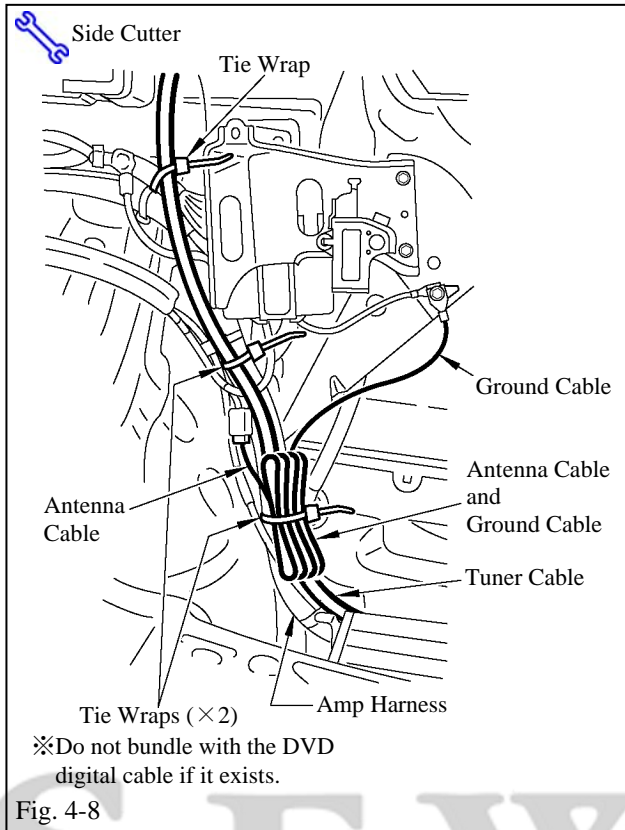

Fig. 4-7

- (i) Connect the antenna cable to the vehicle antenna cable (Fig. 4-6, 4-7).

NOTE: For models not equipped with Lexus Link, connect them after unbinding the soft tape wrap at the tip of the vehicle antenna cable (Fig. 4-6).



- (j) Run the tuner cable, antenna cable and ground cable along with the amp harness.
 - (1) Secure excess ground cable and antenna cable with a tie wrap in the position indicated in the figure (Fig. 4-8).
 - (2) Cut off excess tie wrap with a side cutter.

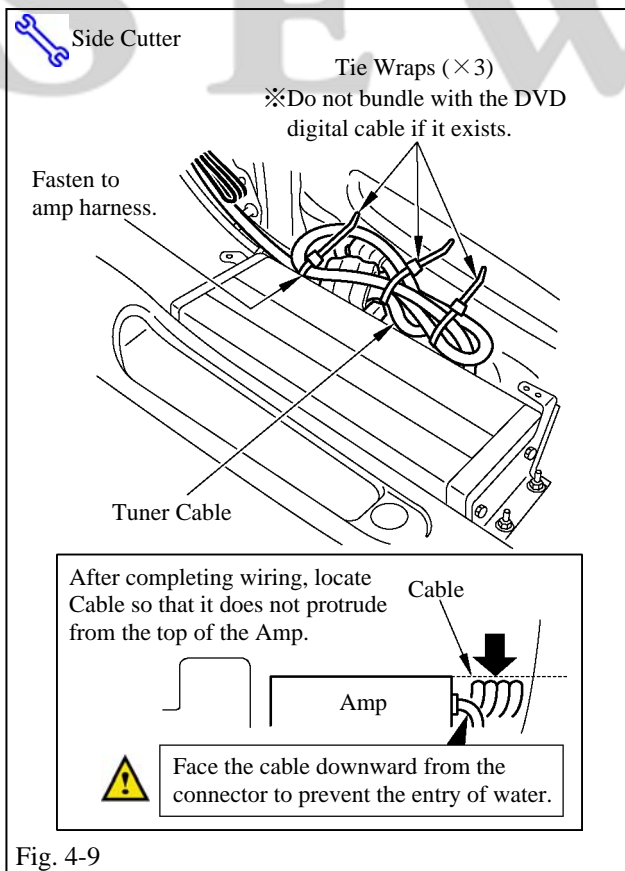

- (3) Bundle tuner cable with a tie wrap in the position indicated in the figure (Fig. 4-9).
- NOTE:** The indications in the figure are for a Mark Levinson audio amp but they are the same for standard audio amps.
- (4) Cut off excess tie wrap with a side cutter.

5. Treating and replacing trunk center trim

(a) Cut the trunk center trim as indicated in the figure (tuner installation part) (Fig. 5-1).

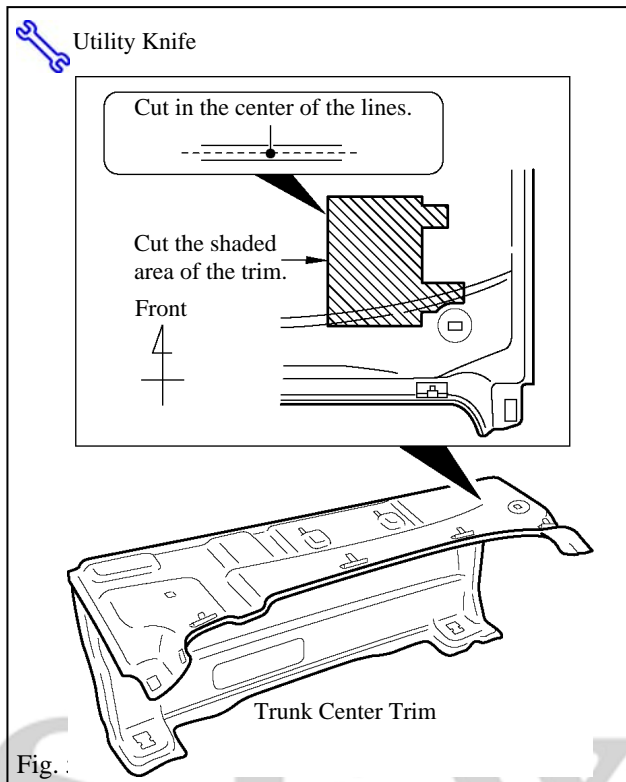

(b) After replacing the trunk side trim (R), replace the trunk center trim (Fig. 5-2).

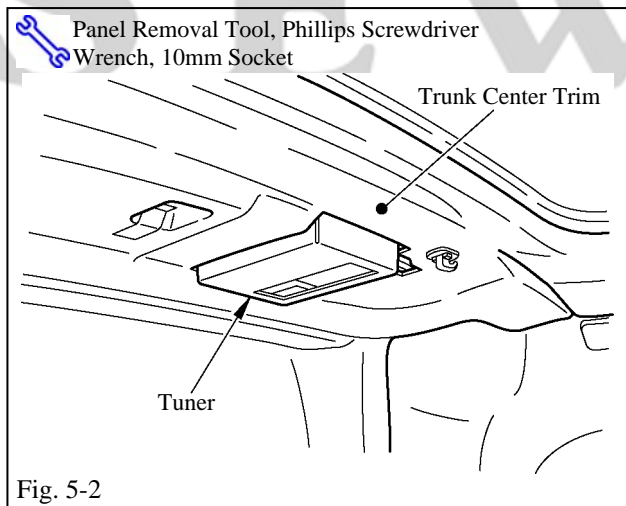

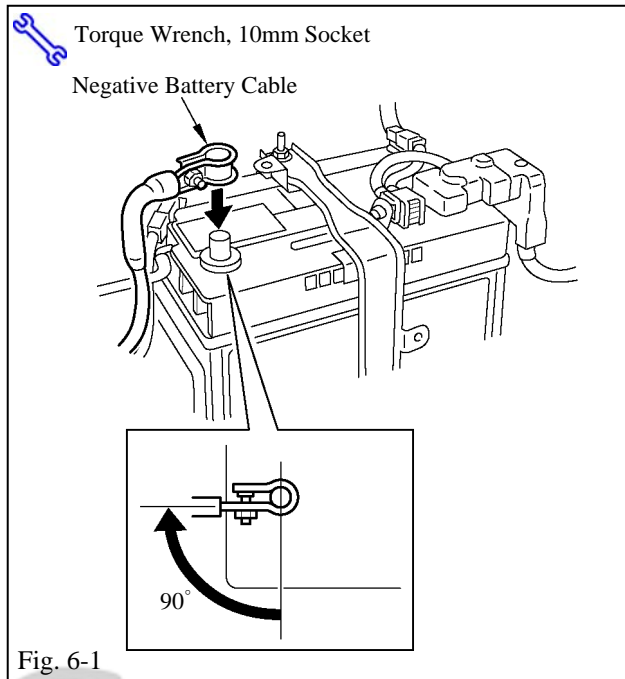

6. Completing the installation

- (a) Complete the reassembly of the vehicle.
 - (1) Reconnect any disconnected connectors.
 - (2) Verify the panels fit together properly with no uneven gaps between them.
- (b) Clean up and remove any trash.
- (c) Reconnect the vehicle's negative battery cable (Fig. 6-1).
 - (1) Position negative terminal battery cable to original factory position.
 - (2) Tighten the nut to 4.1N•m (36 lbf•in).
 - (3) Do not touch the positive terminal with any tool when replacing the cable.



SEWELL

LEXUS GS350/450h/460 2007 - XM SATELLITE RADIO TUNER
Checklist - these points **MUST** be checked to ensure a quality installation.

Check:

Look For:

Accessory Function Checks

- Verify the proper operation of the satellite radio tuner referring to the receiver assy and radio owner's manuals.
- Verify the proper operation of the receiver assy and radio referring to the receiver assy and radio owner's manuals.

Vehicle Function Checks

- Trunk Room Light
- After the battery cable is reconnected, the functional components of the car need to re-initialize. Initialize them with reference to RM02D2U in the vehicle repair manual.

Functioning Trunk Room Light