

11372 / 29134

LEXUS IS250 / IS350 AND GS 350

6/2/2009

GROSS LOAD CAPACITY WHEN USED AS A WEIGHT CARRYING HITCH: 2,000 LBS. TRAILER WEIGHT & 200 LBS. TONGUE WEIGHT.

DO NOT EXCEED VEHICLE MANUFACTURER'S RECOMMENDED TOWING CAPACITY.

WARNING: ALL NON-TRAILER LOADS APPLIED TO THIS PRODUCT MUST BE SUPPORTED BY AUXILIARY STABILIZING STRAPS.

** FAILURE TO PROPERLY SUPPORT NON-TRAILER LOADS WILL VOID PRODUCT WARRANTY**

HAVING INSTALLATION QUESTIONS? CALL TECHNICAL SUPPORT AT 1-800-798-0813

TOOLS REQUIRED
8 & 17mm SOCKETS
12" EXTENSION
RATCHET
TORQUE WRENCH
TIN SNIPS

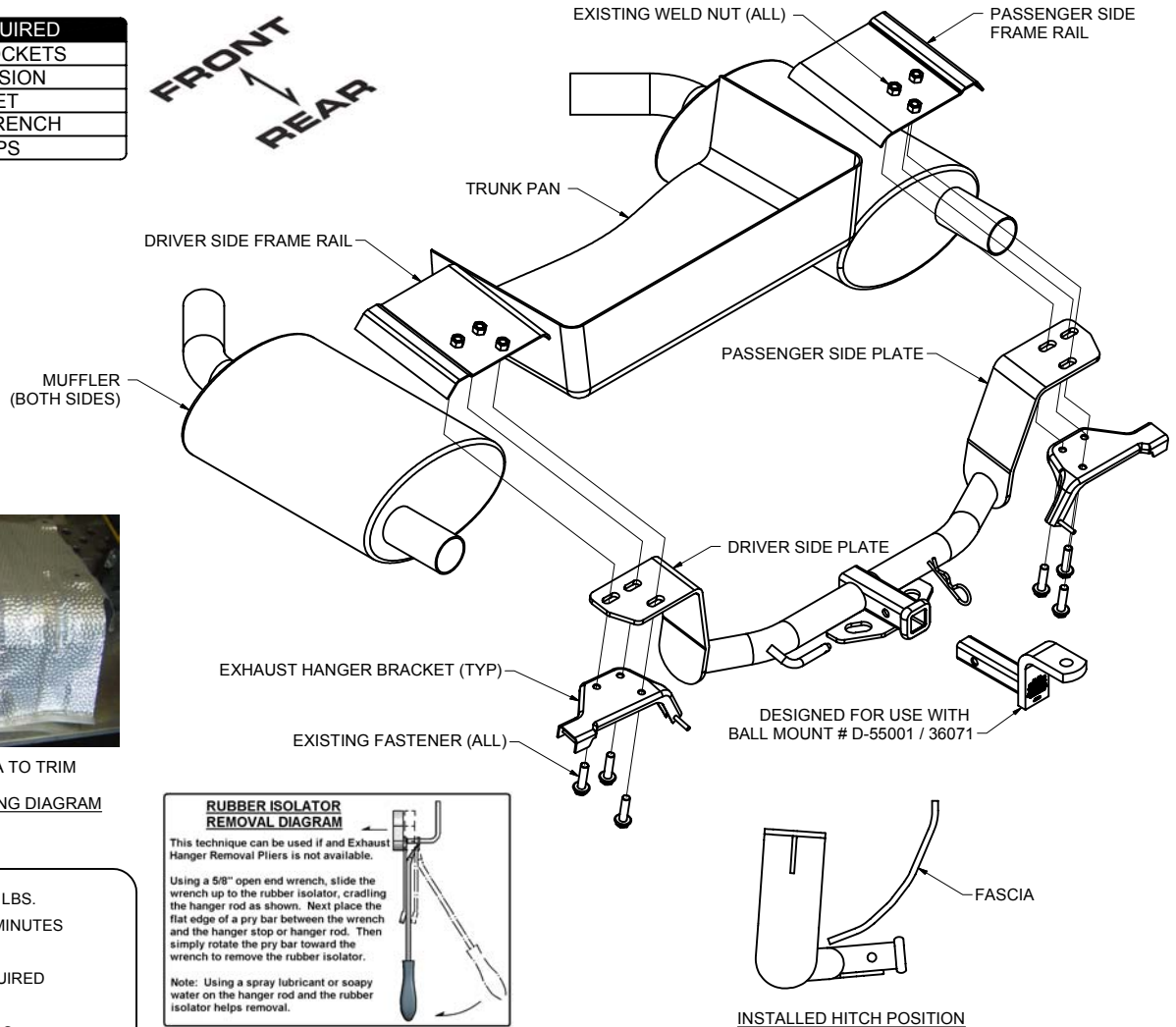

3-1/2" AREA TO TRIM
HEAT SHIELD TRIMMING DIAGRAM

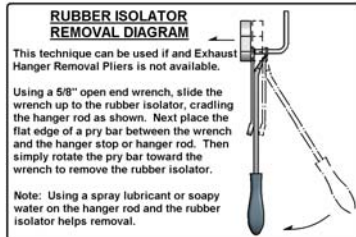

RUBBER ISOLATOR REMOVAL DIAGRAM
This technique can be used if and Exhaust Hanger Removal Pliers is not available.
Using a 5/8" open end wrench, slide the wrench up to the rubber isolator, cradling the hanger rod as shown. Next place the flat edge of a pry bar between the wrench and the hanger stop or hanger rod. Then simply rotate the pry bar toward the wrench to remove the rubber isolator.
Note: Using a spray lubricant or soapy water on the hanger rod and the rubber isolator helps removal.

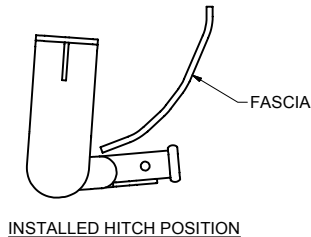

INSTALLED HITCH POSITION

- HITCH WEIGHT: 24 LBS.
INSTALL TIME: 45 MINUTES
INSTALL NOTES:
- NO DRILLING REQUIRED
- LOWER EXHAUST
- TRIM HEAT SHIELDS

INSTALLATION STEPS

1. Lower the exhaust by removing the (2) rearmost rubber isolators from the hanger bracket on each muffler, allowing the exhaust to hang. (See Rubber Isolator Removal Diagram.)
2. Remove the (6) hex flange bolts securing the exhaust hanger brackets and remove the brackets. Save the bolts and brackets for use in Step 5.
3. Remove the (4) nuts securing each heat shield and remove the heat shields from the vehicle. Trim the heat shields to clear the hitch side plates as shown. (See Heat Shield Trimming Diagram.)
4. Reinstall the heat shields with the nuts removed in Step 3.
5. Raise the hitch into position against the frame rails and reinstall the exhaust hanger brackets using the (6) hex flange bolts removed in Step 2. (Note: Hitch is sandwiched between the frame rails and exhaust hanger brackets.)
6. Torque all M12 hardware to 65 ft-lbs.
7. Raise the exhaust and reinstall the (4) rubber isolators. **Note:** On the GS350, bend the lower rear edge of the heat shields away from the side plates.

PERIODICALLY CHECK THIS RECEIVER HITCH TO ENSURE THAT ALL FASTENERS ARE TIGHT AND THAT ALL STRUCTURAL COMPONENTS ARE SOUND.

Curt Manufacturing Inc., warrants this product to be free of defects in material and/or workmanship at the time of retail purchase by the original purchaser. If the product is found to be defective, Curt Manufacturing Inc., may repair or replace the product, at their option, when the product is returned, prepaid, with proof of purchase. Alteration to, misuse of, or improper installation of this product voids the warranty. Curt Manufacturing Inc.'s liability is limited to repair or replacement of products found to be defective, and specifically excludes liability for incidental or consequential loss or damage.