

REMOVAL

1. REMOVE REAR WHEEL

Torque: 103 N·m (1,050 kgf·cm, 76 ft·lbf)

2. REMOVE SUSPENSION MEMBER BRACE

Remove the 2 bolts and suspension member brace.

Torque: 50 N·m (510 kgf·cm, 37 ft·lbf)

3. REMOVE COTTER PIN, LOCK CAP AND LOCK NUT

(a) Remove the cotter pin and lock cap.

(b) With depressing the brake pedal, remove the nut.

Torque: 289 N·m (2,950 kgf·cm, 213 ft·lbf)

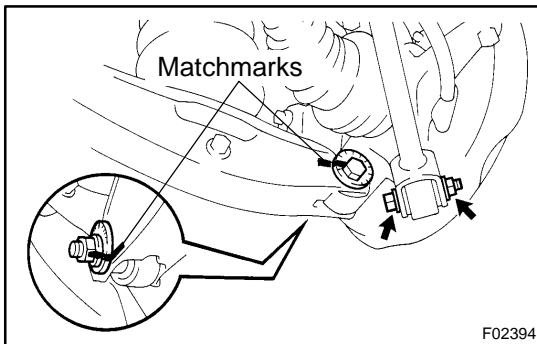

4. REMOVE DRIVE SHAFT

(a) Place matchmarks on the adjusting cam and lower suspension arm.

(b) Remove the bolt and nut, disconnect the No.2 lower suspension arm from the axle hub.

Torque: 110 N·m (1,120 kgf·cm, 81 ft·lbf)

(c) Remove the bolt and nut, disconnect the No.1 lower suspension arm from the axle hub.

Torque: 75 N·m (765 kgf·cm, 55 ft·lbf)

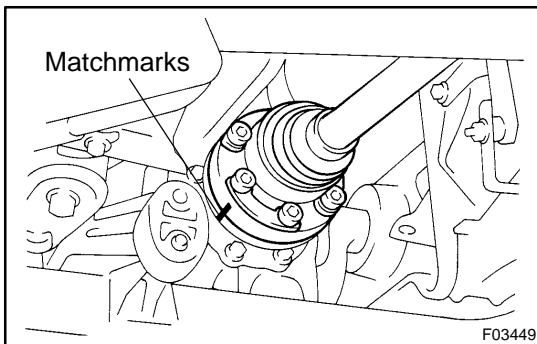

(d) Place matchmarks on the drive shaft and side gear shaft.

NOTICE:

Do not punch to mark the matchmarks. Use paint etc.

(e) Using a 10 mm hexagon wrench, remove the 6 hexagon bolts and 2 washers with depressing the brake pedal.

Torque: 83 N·m (850 kgf·cm, 61 ft·lbf)

HINT:

At the time of installation, apply a light coat of engine oil on the threads of the bolts.

(f) Hold the inboard joint side of the drive shaft so that the outboard joint side does not bend too much.

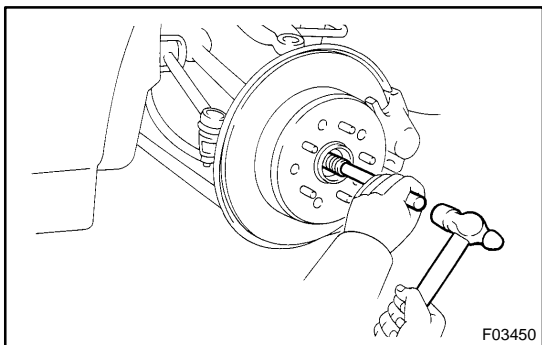

- (g) Using a brass bar and hammer, lightly tap the end of the drive shaft, disengage the axle hub and remove the drive shaft.

NOTICE:

Be careful not to damage the boots, end cover, speed sensor rotor of the drive shaft and oil seal of the axle hub.