

Last Modified: 7-13-2007		1.7 K
Service Category: Vehicle Interior	Section: Heating/Air Conditioning	
Model Year: 2008	Model: ES350	Doc ID: RM000002DHA003X
Title: AIR CONDITIONING: COMPRESSOR AND MAGNETIC CLUTCH: COMPONENTS (2008 ES350)		

COMPONENTS

ILLUSTRATION

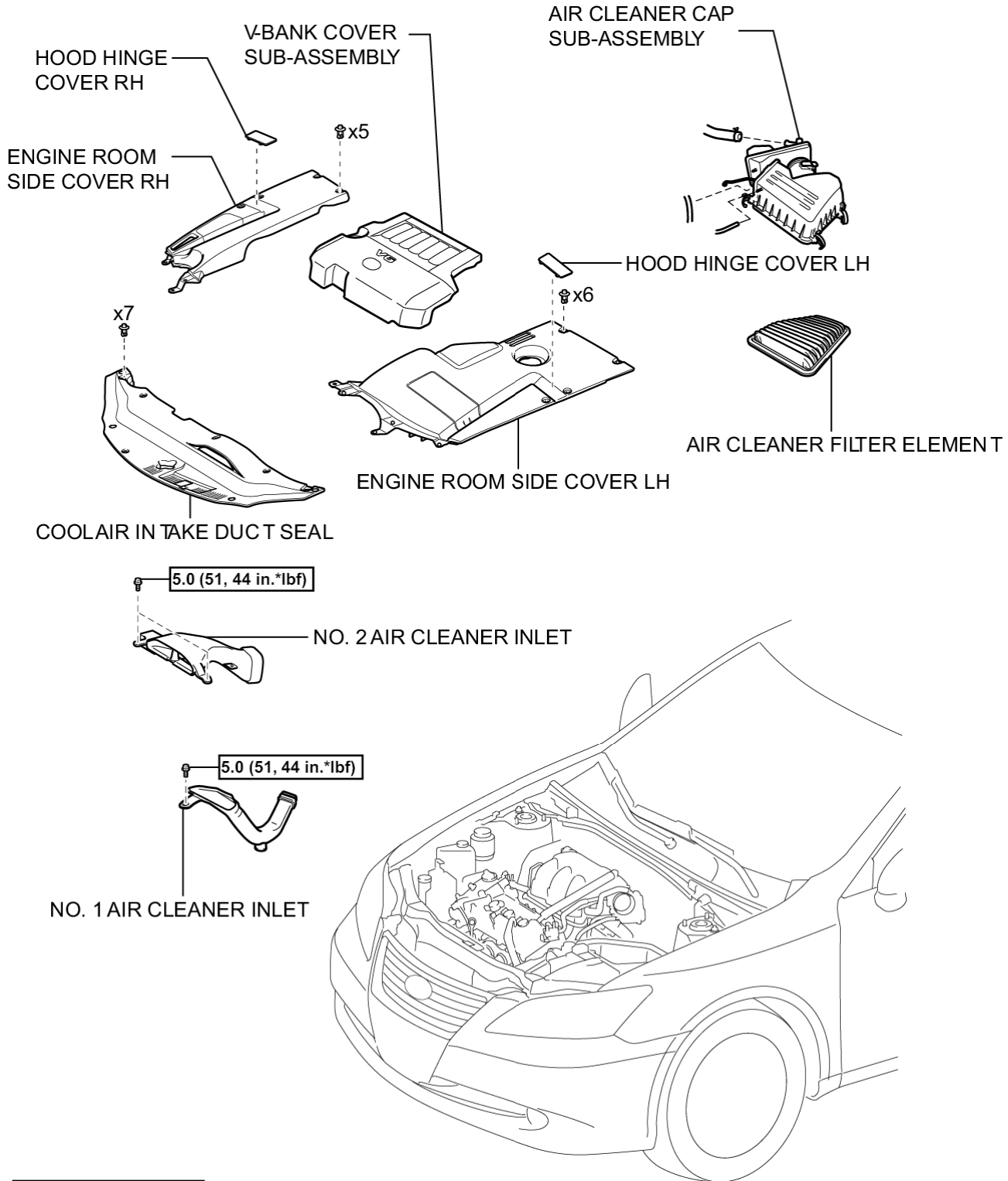

N*m (kgf*cm, ft.*lbf) : Specified torque

T

ILLUSTRATION

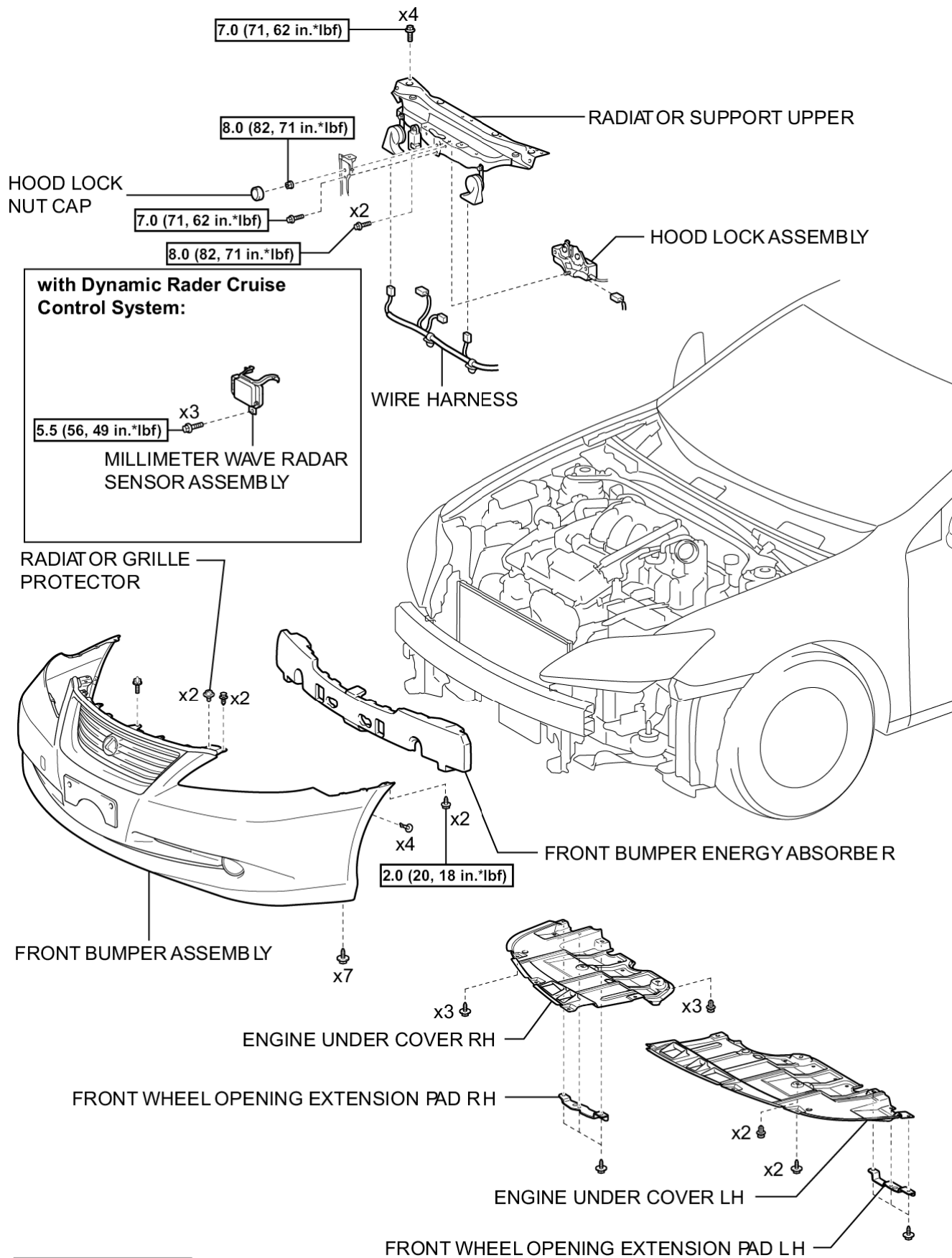

N*m (kgf*cm, ft.*lbf): Specified torque

T

ILLUSTRATION

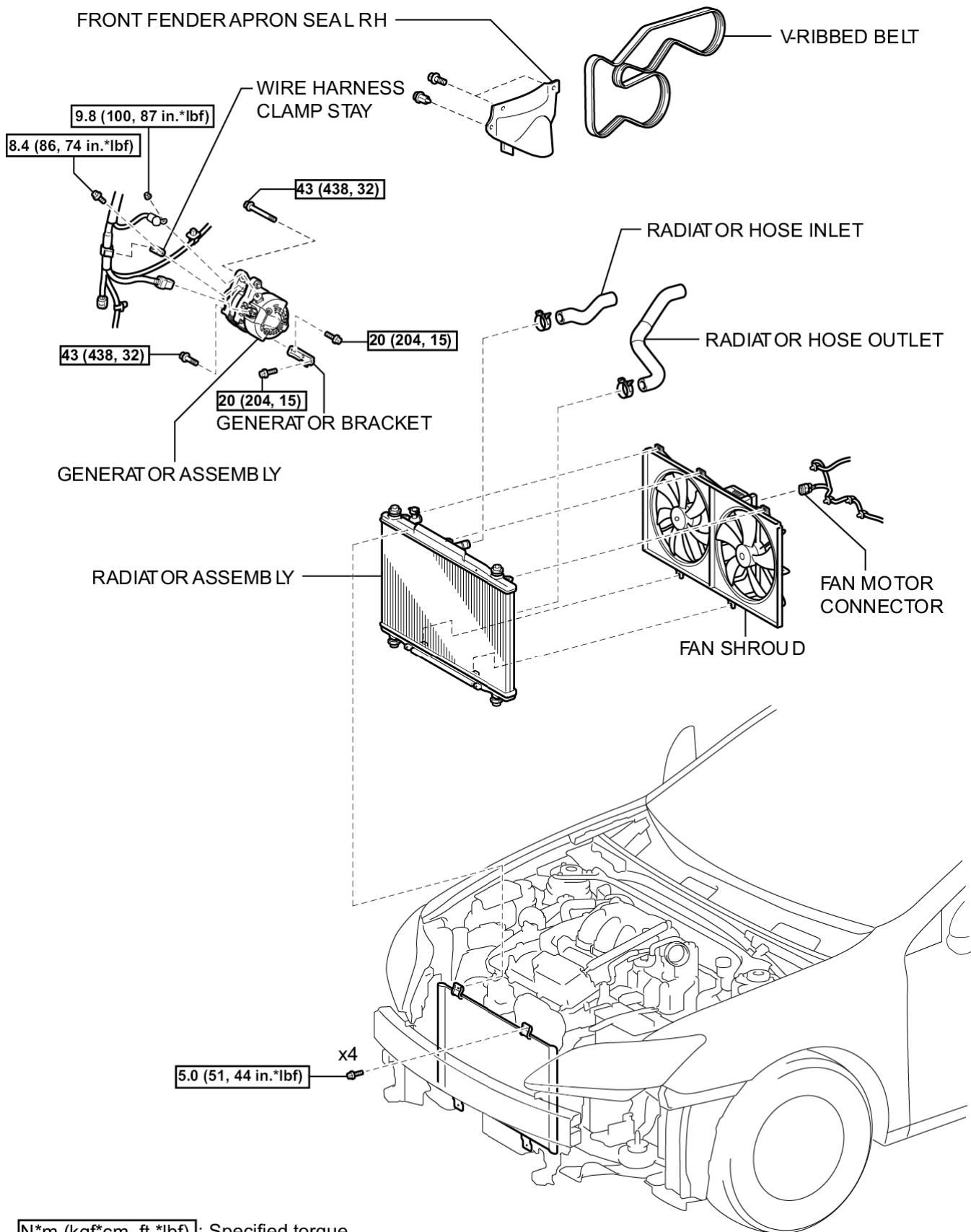

N*m (kgf*cm, ft.*lbf): Specified torque

ILLUSTRATION

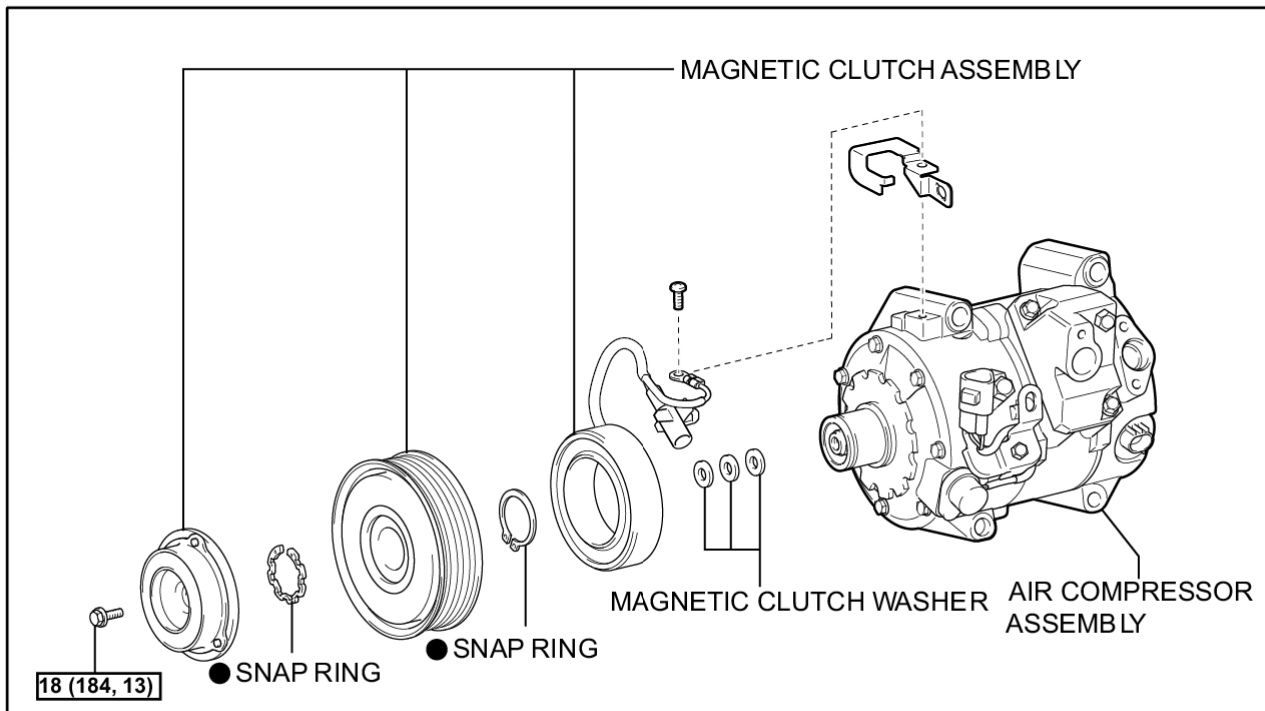
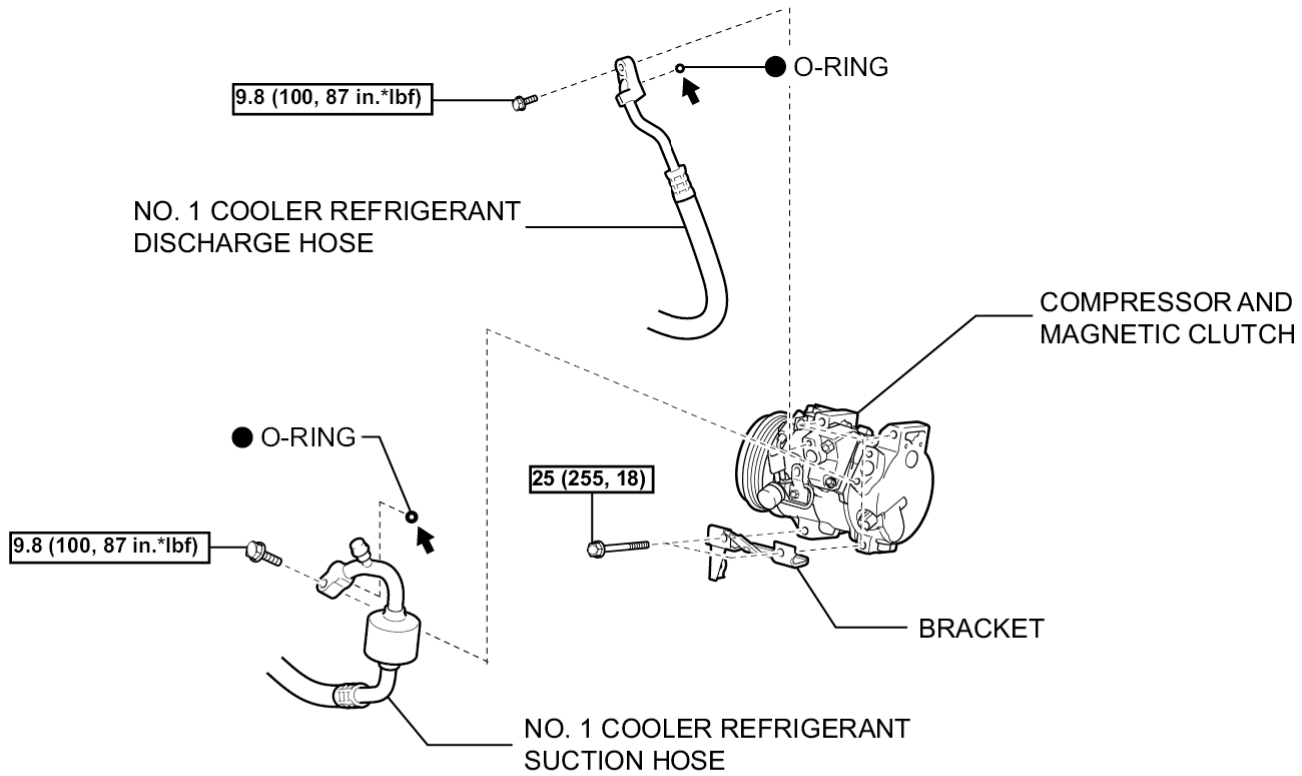

← Compressor oil ND-OIL 8 or equivalent ● Non-reusable part **N*m (kgf*cm, ft.*lbf)**: Specified torque

