

Last Modified: 7-13-2007		1.7 A
Service Category: Vehicle Interior	Section: Interior Panels/Trim	
Model Year: 2008	Model: ES350	Doc ID: RM000002DME002X
Title: INSTRUMENT PANEL: INSTRUMENT PANEL SAFETY PAD: REMOVAL (2008 ES350)		

## REMOVAL

### 1. PRECAUTION

INFO

### 2. ALIGN FRONT WHEELS FACING STRAIGHT AHEAD

### 3. DISCONNECT CABLE FROM NEGATIVE BATTERY TERMINAL

#### CAUTION:

Wait for 90 seconds after disconnecting the cable to prevent airbag deployment INFO.

### 4. REMOVE LOWER NO. 3 STEERING WHEEL COVER INFO

### 5. REMOVE LOWER NO. 2 STEERING WHEEL COVER INFO

### 6. REMOVE STEERING PAD INFO

### 7. REMOVE STEERING WHEEL ASSEMBLY INFO

### 8. REMOVE FRONT DOOR SCUFF PLATE LH INFO

### 9. REMOVE FRONT DOOR OPENING TRIM COVER LH INFO

### 10. REMOVE SIDE INSTRUMENT PANEL LH

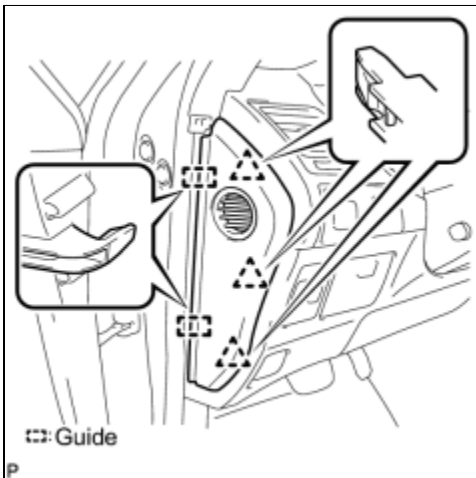

(a) Disengage the 3 clips.

(b) Disengage the 2 guides and remove the side instrument panel LH.

### 11. REMOVE INSTRUMENT PANEL FINISH PANEL END LH

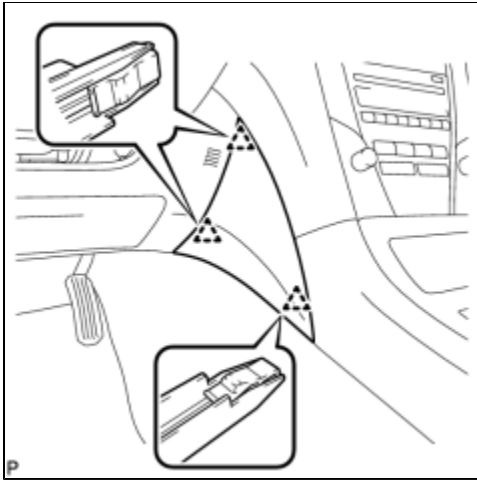

(a) Disengage the 3 clips and remove the instrument panel finish panel end LH.

## 12. REMOVE LOWER INSTRUMENT PANEL SUB-ASSEMBLY

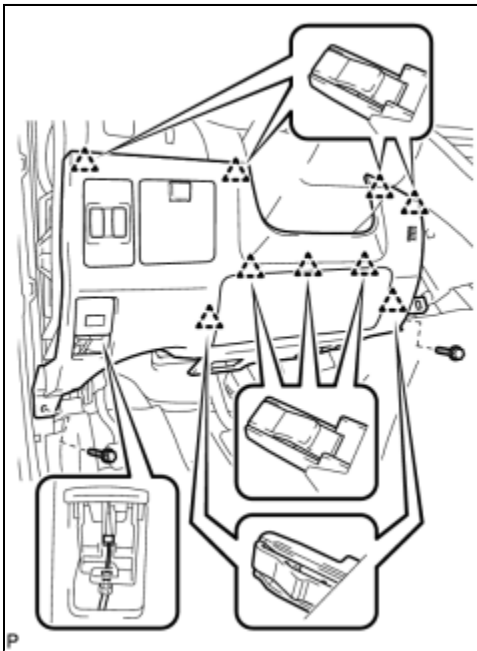

(a) Remove the 2 bolts <A>.

(b) Disconnect the hood lock control cable assembly.

(c) Disengage the 9 clips.

(d) Disconnect each connector and remove the lower instrument panel sub-assembly.

## 13. REMOVE STEERING COLUMN COVER

(a) Remove the 2 screws <J>.

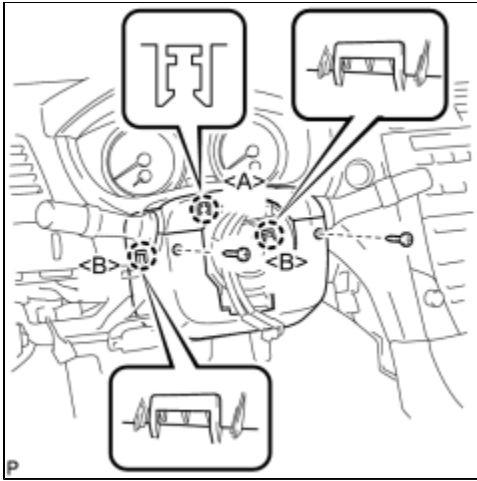

(b) Disengage the 2 claws <B> and remove the lower steering column cover.

(c) Disengage the claw <A> and remove the upper steering column cover.

#### 14. REMOVE TILT AND TELESCOPIC SWITCH [INFO](#)

#### 15. REMOVE TURN SIGNAL SWITCH ASSEMBLY WITH SPIRAL CABLE SUB-ASSEMBLY [INFO](#)

#### 16. REMOVE INSTRUMENT CLUSTER FINISH PANEL SUB-ASSEMBLY

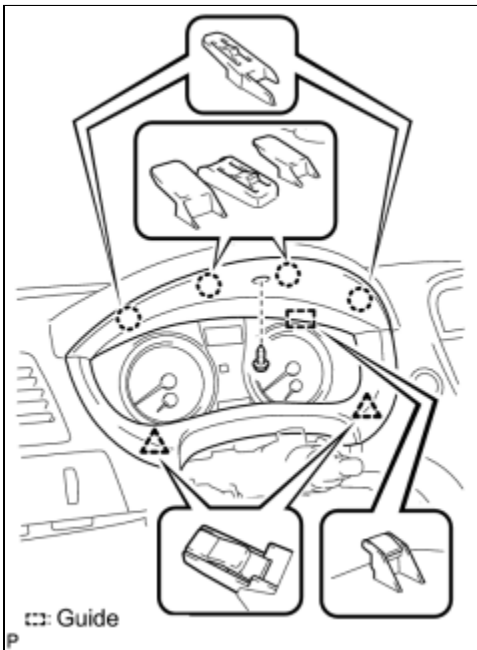

(a) Remove the screw <B>.

(b) Disengage the 2 clips.

(c) Disengage the guide and the 4 claws, and remove the instrument cluster finish panel sub-assembly.

#### 17. REMOVE COMBINATION METER ASSEMBLY

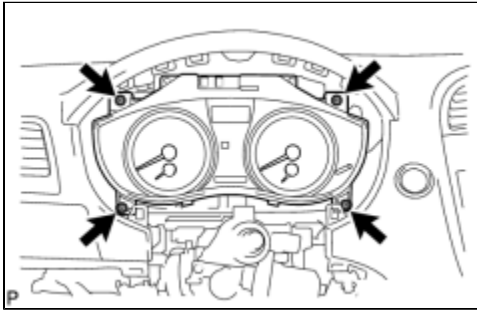

(a) Remove the 4 screws <B> or <C>.

(b) Disconnect each connector and remove the combination meter assembly.

### 18. REMOVE NO. 1 SWITCH HOLE BASE

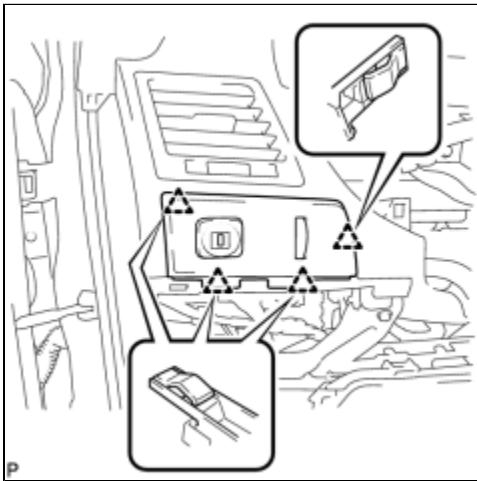

(a) Disengage the 4 clips.

(b) Disconnect each connector and remove the No. 1 switch hole base.

### 19. REMOVE INSTRUMENT PANEL FINISH PANEL END RH

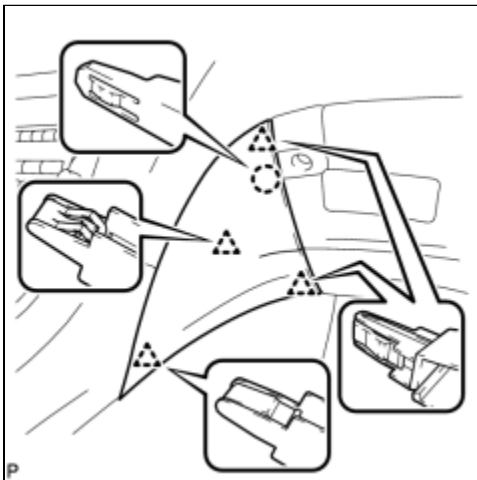

(a) Disengage the claw and 4 clips, and remove the instrument panel finish panel end RH.

### 20. REMOVE FRONT DOOR SCUFF PLATE RH INFO

**21. REMOVE FRONT DOOR OPENING TRIM COVER RH**

INFO

**22. REMOVE NO. 2 INSTRUMENT PANEL UNDER COVER SUB-ASSEMBLY**

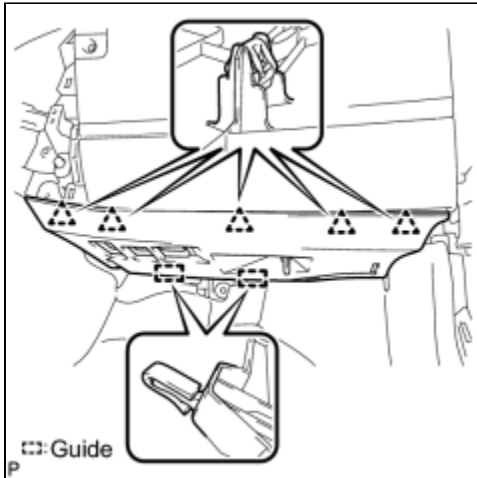

(a) Disengage the 5 clips.

(b) Disengage the 2 guides and remove the No. 2 instrument panel under cover sub-assembly.

(c) Disconnect the connector.

**23. REMOVE SIDE INSTRUMENT PANEL RH**

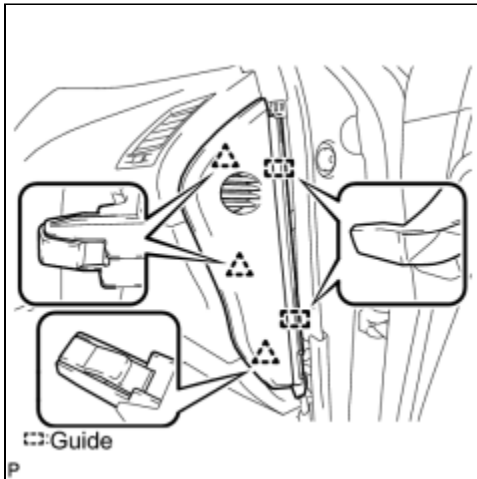

(a) Disengage the 3 clips.

(b) Disengage the 2 guides and remove the side instrument panel RH.

**24. REMOVE FRONT PASSENGER SIDE KNEE AIRBAG ASSEMBLY**

INFO

**25. REMOVE LOWER INSTRUMENT PANEL RH**

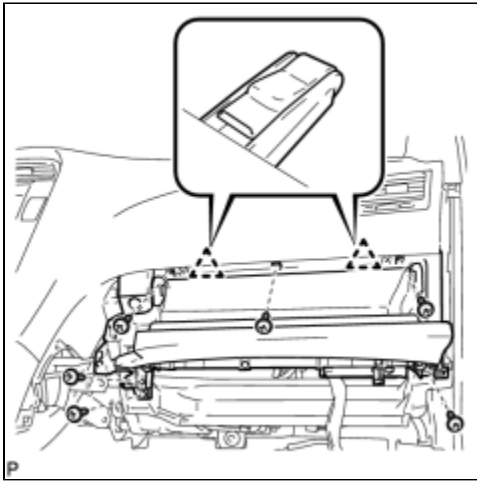

(a) Remove the 6 screws <D>.

(b) Disengage the 2 clips.

(c) Disconnect each connector and remove the lower instrument panel RH

## 26. REMOVE SHIFT LEVER KNOB SUB-ASSEMBLY

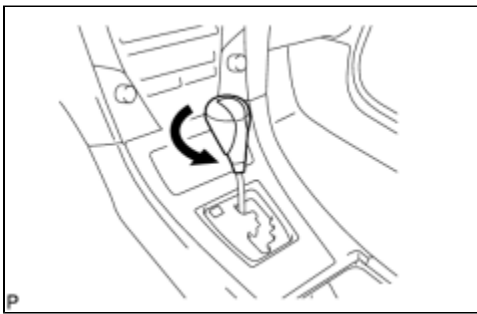

(a) Turn the shift lever knob counterclockwise and remove the shift lever knob sub-assembly.

## 27. REMOVE UPPER CONSOLE PANEL ASSEMBLY WITH FRONT ASH RECEPTACLE

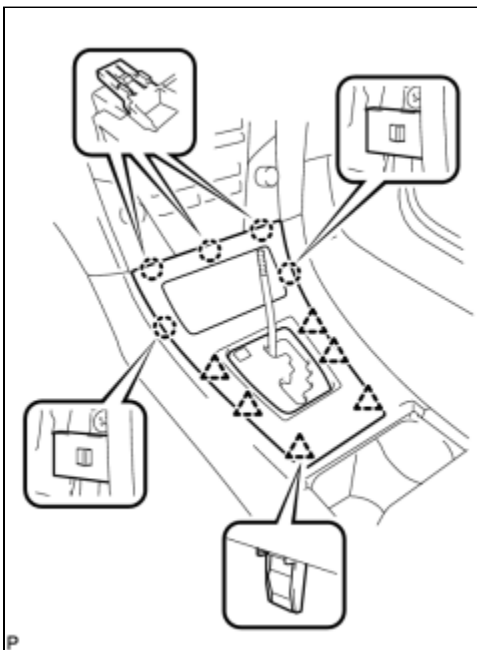

(a) Disengage the 5 claws and 6 clips.

(b) Disconnect the connector and remove the upper console panel assembly with front ash receptacle.

## 28. REMOVE NO. 2 INSTRUMENT PANEL REGISTER ASSEMBLY

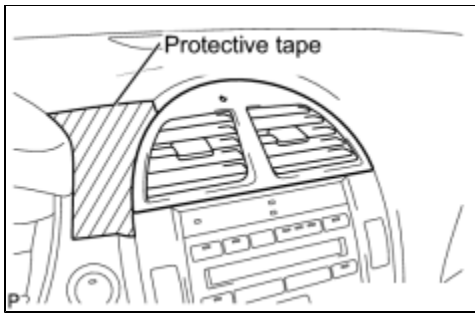

(a) Apply protective tape to the area shown in the illustration.

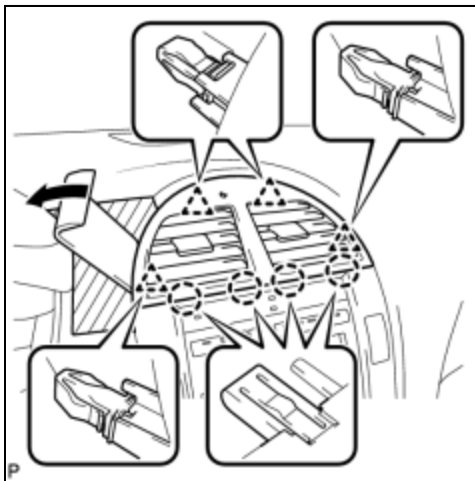

(b) Using a moulding remover, disengage the 4 claws and 4 clips, and remove the No. 2 instrument panel register assembly.

(c) Disconnect the connector.

## 29. REMOVE INTEGRATION CONTROL PANEL WITH RADIO RECEIVER ASSEMBLY (w/o Navigation System) [INFO](#)

## 30. REMOVE MULTI-DISPLAY WITH RADIO RECEIVER ASSEMBLY (w/ Navigation System) [INFO](#)

## 31. REMOVE HEATER SEAT SWITCH CONSOLE BASE (w/o Seat Heater System)

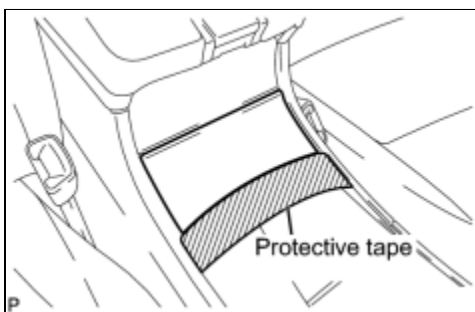

(a) Apply protective tape to the area shown in the illustration.

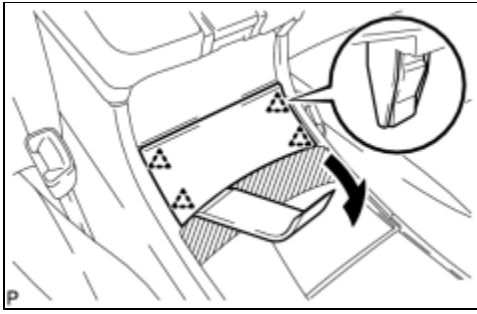

(b) Using a moulding remover, disengage the 4 clips and remove the heater seat switch console base.

### 32. REMOVE HEATER SEAT SWITCH CONSOLE BASE (w/ Seat Heater System)

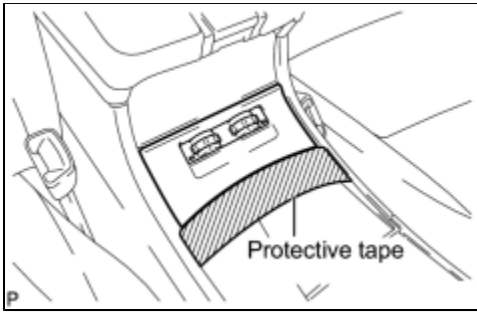

(a) Apply protective tape to the area shown in the illustration.

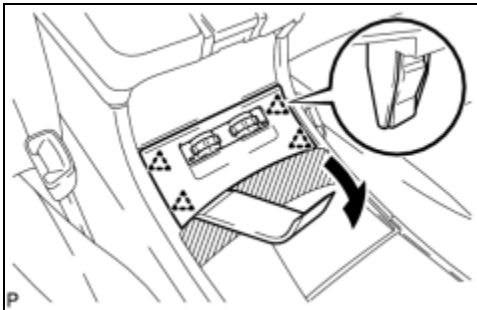

(b) Using a moulding remover, disengage the 4 clips.

(c) Disconnect each connector and remove the heater seat switch console base.

### 33. REMOVE CONSOLE BOX POCKET

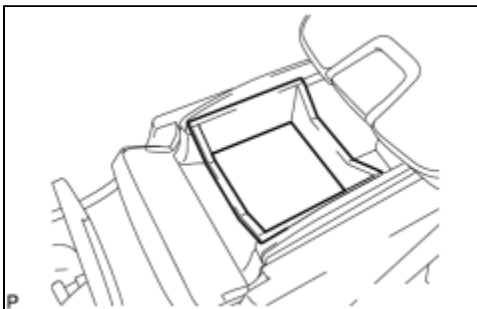

(a) Remove the console box pocket.

### 34. REMOVE CONSOLE BOX CARPET



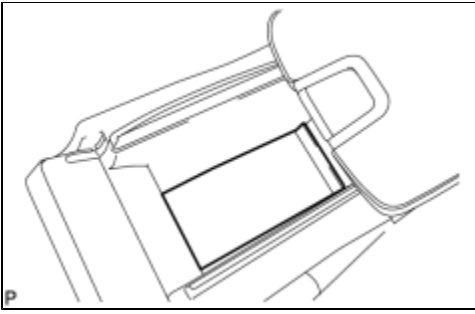

(a) Remove the console box carpet.

### 35. REMOVE CONSOLE REAR END PANEL SUB-ASSEMBLY

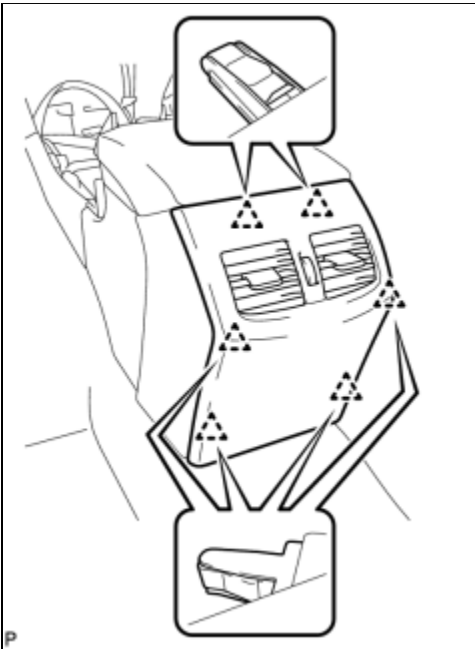

(a) Disengage the 6 claws and remove the console rear end panel sub-assembly.

### 36. REMOVE REAR CONSOLE BOX ASSEMBLY

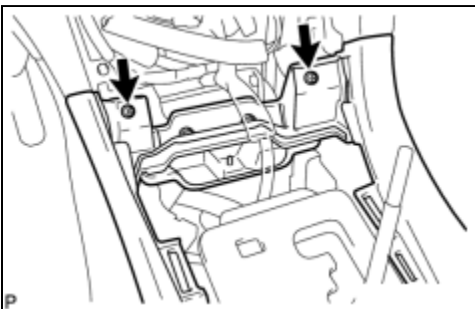

(a) Remove the 2 screws <F>.

(b) Remove the 2 bolts <E>.

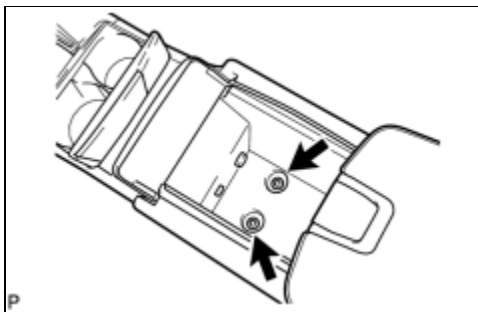

(c) Remove the 2 bolts <E>.



(d) Disengage the 4 clips and remove the rear console box assembly.

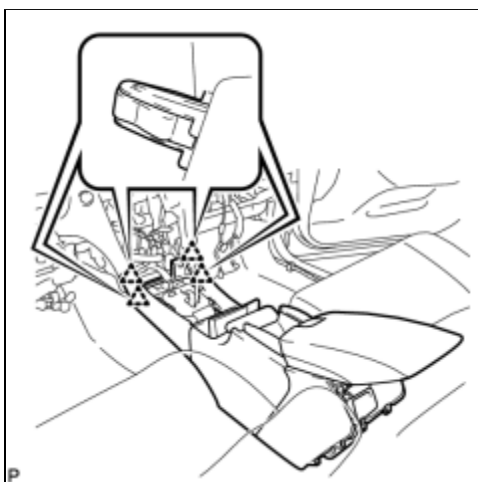

(e) Disconnect each connector.

**37. REMOVE FRONT PILLAR GARNISH LH** INFO

**38. REMOVE NO. 1 INSTRUMENT PANEL SPEAKER PANEL SUB-ASSEMBLY**

(a) Using a screwdriver, disengage the 2 clips.

**HINT:**

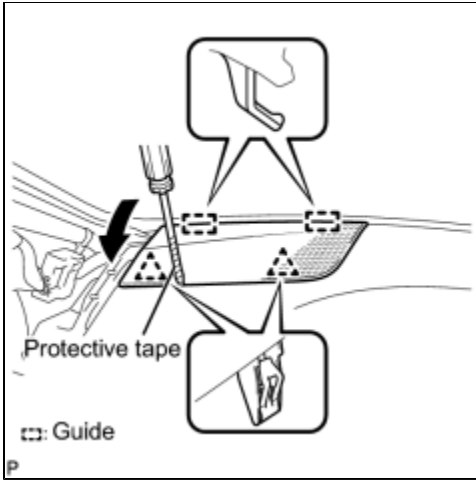

Tape the screwdriver tip before use.

(b) Disengage the 2 guides and remove the No. 1 instrument panel speaker panel sub-assembly.

**39. REMOVE FRONT NO. 2 SPEAKER ASSEMBLY (for LH Side)** INFO

**40. REMOVE NO. 1 INSTRUMENT PANEL REGISTER ASSEMBLY**

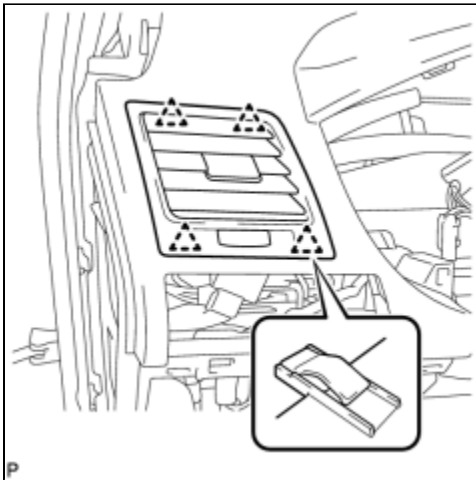

(a) Disengage the 4 clips and remove the No. 1 instrument panel register assembly.

**41. REMOVE FRONT PILLAR GARNISH RH** INFO

**42. REMOVE NO. 2 INSTRUMENT PANEL SPEAKER PANEL SUB-ASSEMBLY**

(a) Using a screwdriver, disengage the 2 clips.

**HINT:**

Tape the screwdriver tip before use.

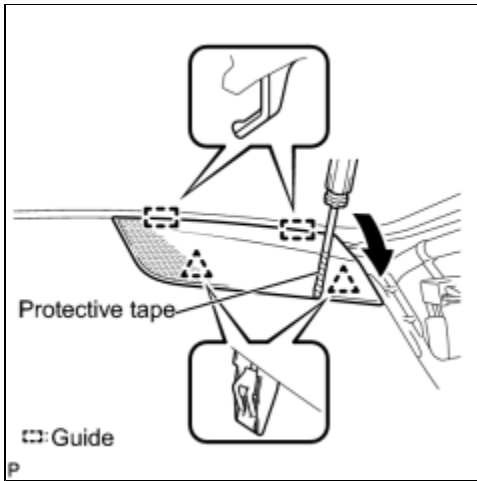

(b) Disengage the 2 guides and remove the No. 2 instrument panel speaker panel sub-assembly.

#### 43. REMOVE FRONT NO. 2 SPEAKER ASSEMBLY (for RH Side)

**HINT:** Use the same procedures described for the LH side [INFO](#).

#### 44. REMOVE NO. 3 INSTRUMENT PANEL REGISTER ASSEMBLY

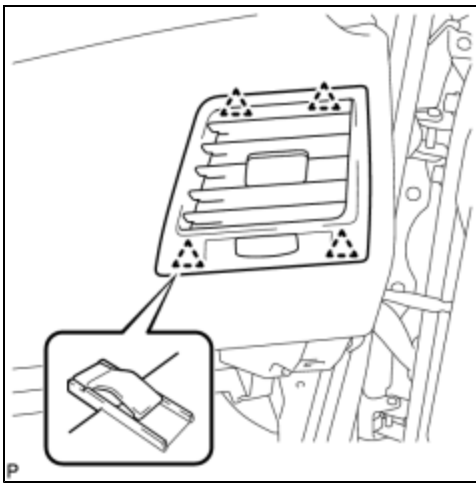

(a) Disengage the 4 clips and remove the No. 3 instrument panel register assembly.

#### 45. REMOVE NO. 1 SPEAKER HOLE COVER

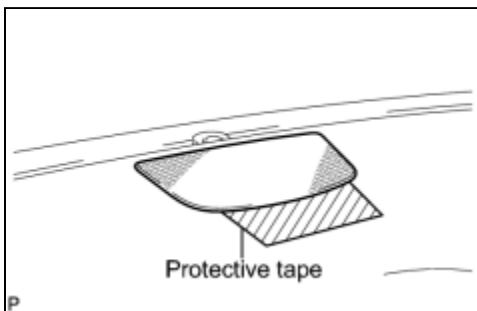

(a) Apply protective tape to the area shown in the illustration.

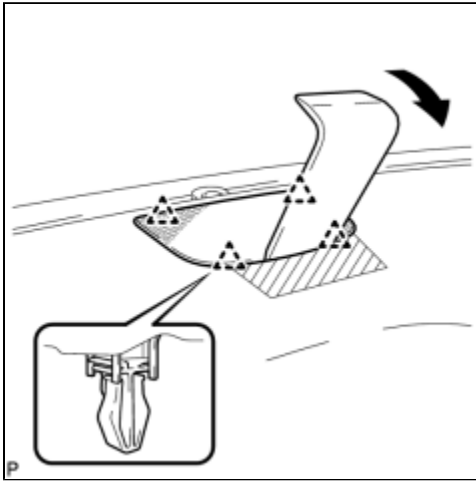

(b) Using a moulding remover, disengage the 4 clips and remove the No. 1 speaker hole cover.

**46. REMOVE FRONT STEREO COMPONENT SPEAKER ASSEMBLY** INFO

**47. REMOVE NO. 1 INSTRUMENT PANEL MOUNTING BRACKET**

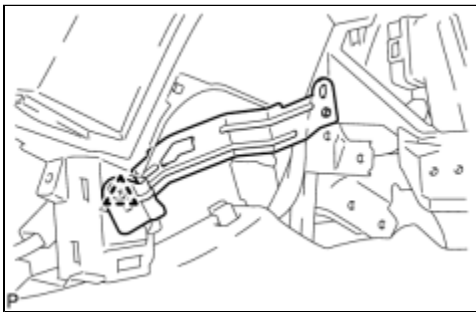

(a) Remove the clip and the No. 1 instrument panel mounting bracket.

**48. REMOVE PUSH START SWITCH**

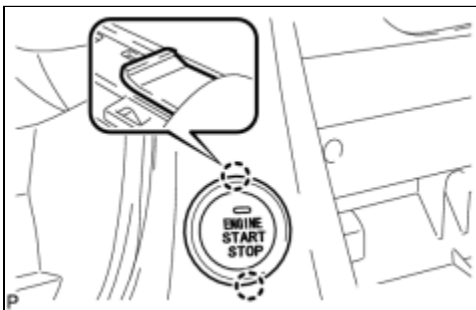

(a) Disengage the 2 claws and remove the push start switch.

(b) Disconnect the connector.

**49. DISCONNECT INSTRUMENT PANEL WIRE ASSEMBLY** INFO

**50. REMOVE ROOM TEMPERATURE SENSOR** INFO

**51. REMOVE INSTRUMENT PANEL SAFETY PAD ASSEMBLY (w/o DVD Player)**

(a) Disconnect each connector.

- (b) Disengage each clamp.
- (c) Remove the 2 passenger airbag bolts <K>.
- (d) Remove the clip.
- (e) Remove the bolt <L>.

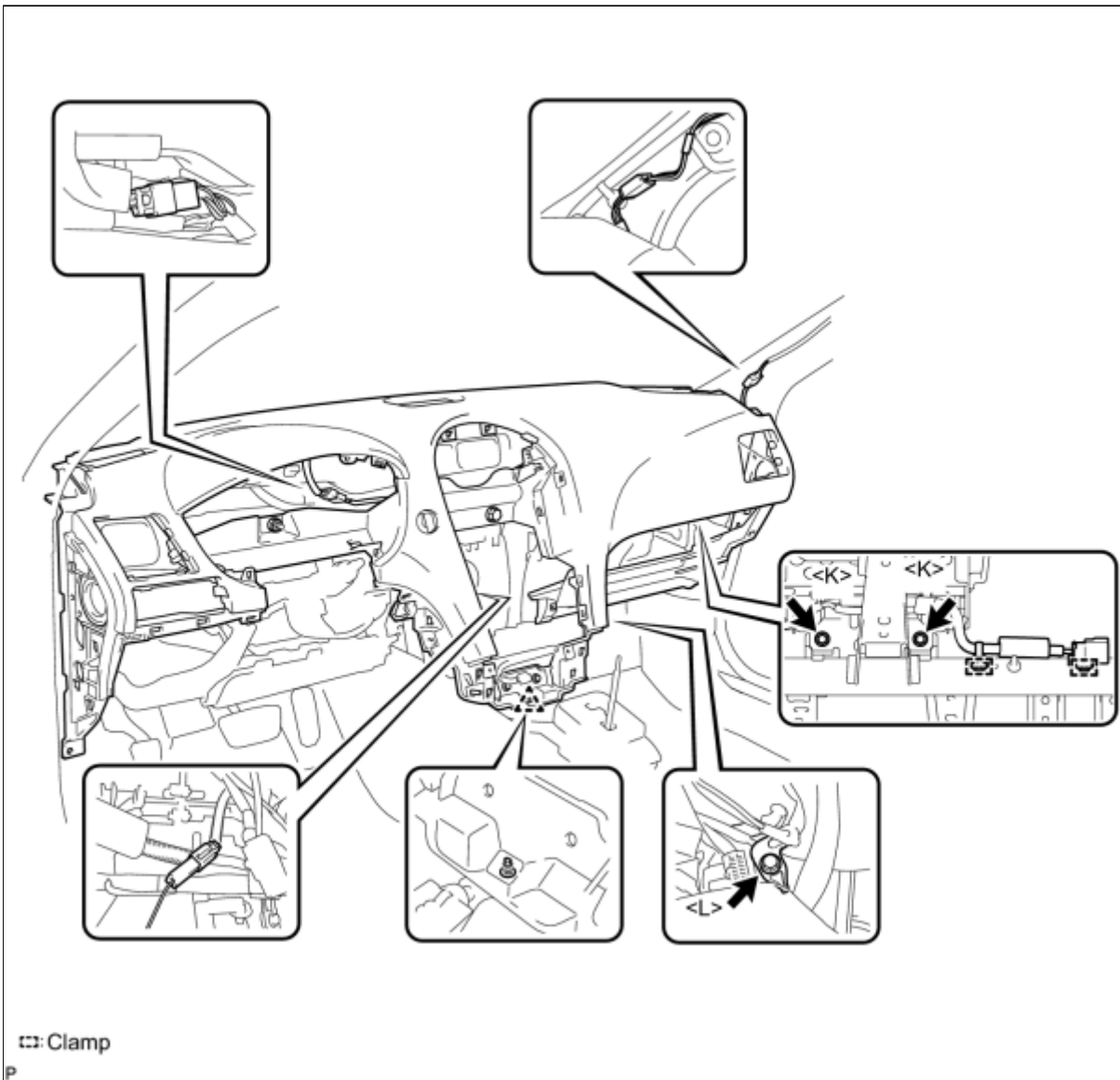

- (f) Remove the 5 bolts <G> and nut <H>.
- (g) Remove the 4 clips.
- (h) Disengage the 5 claws and remove the instrument panel safety pad assembly.

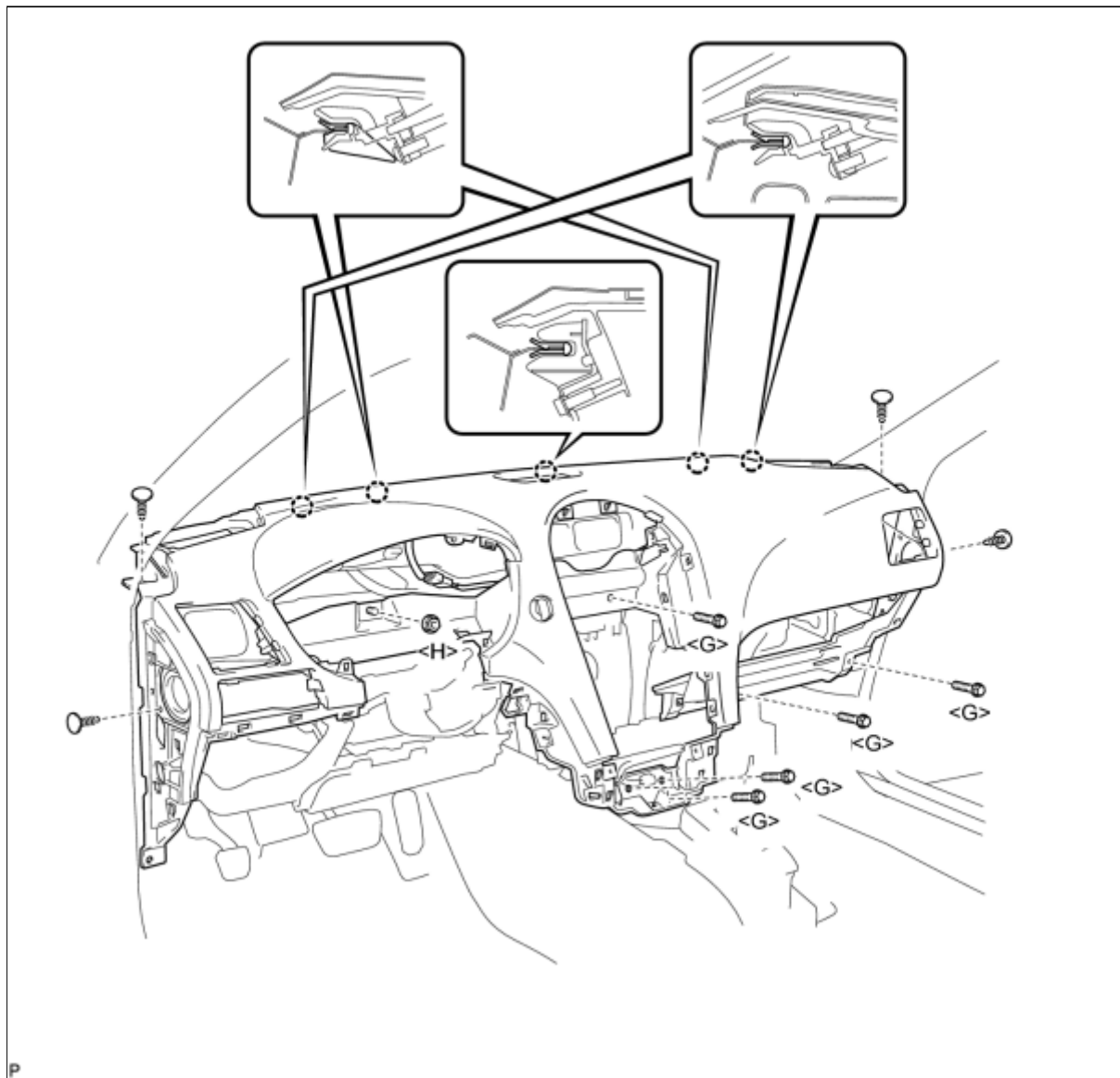

## 52. REMOVE INSTRUMENT PANEL SAFETY PAD ASSEMBLY (w/ DVD Player)

- (a) Disconnect each connector.
- (b) Disengage each clamp.
- (c) Remove the 2 passenger airbag bolts <K>.
- (d) Remove the clip.
- (e) Remove the bolt <L>.

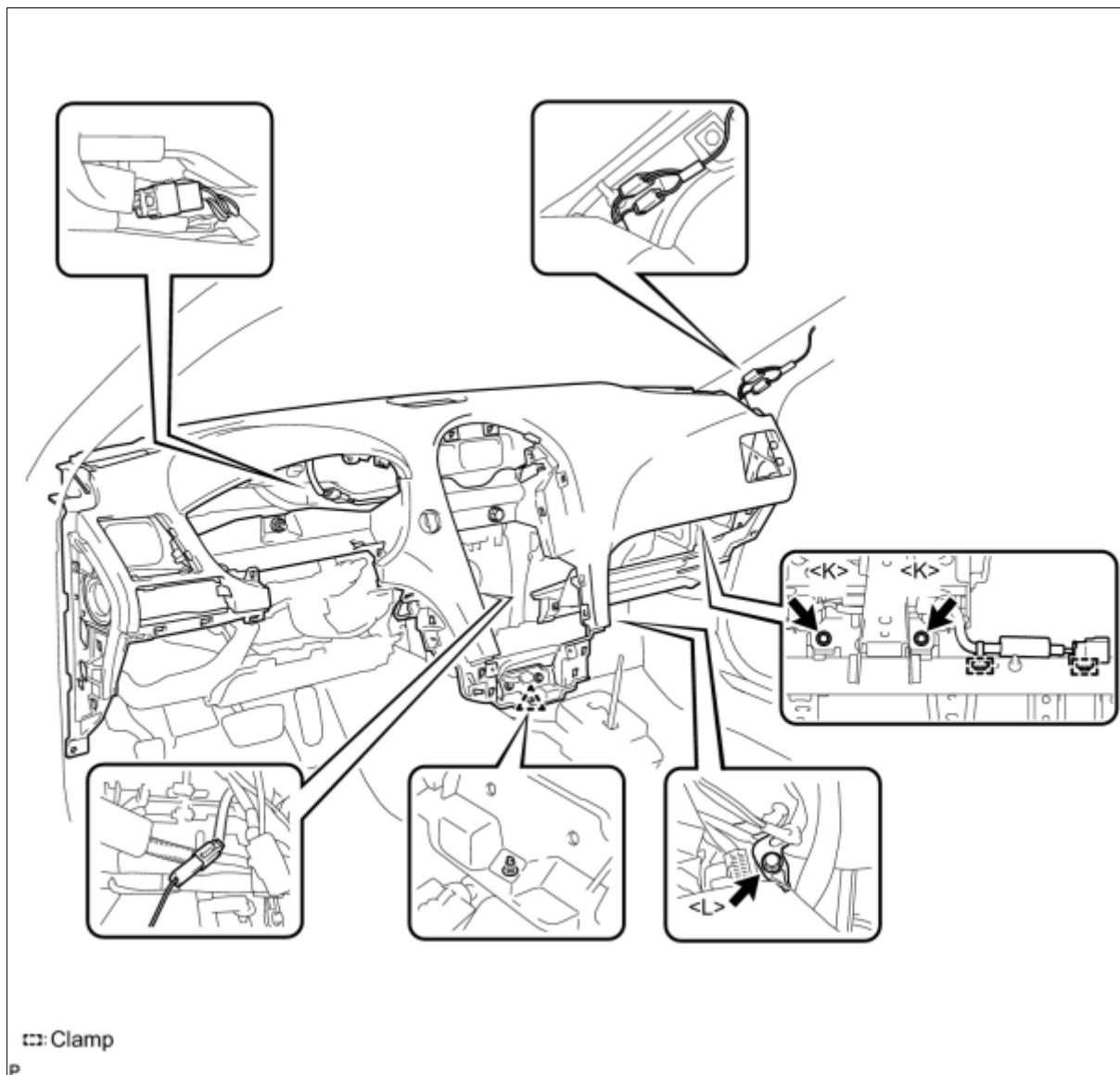

(f) Remove the 5 bolts <G> and nut <H>.

(g) Remove the 4 clips.

(h) Disengage the 5 claws and remove the instrument panel safety pad assembly.



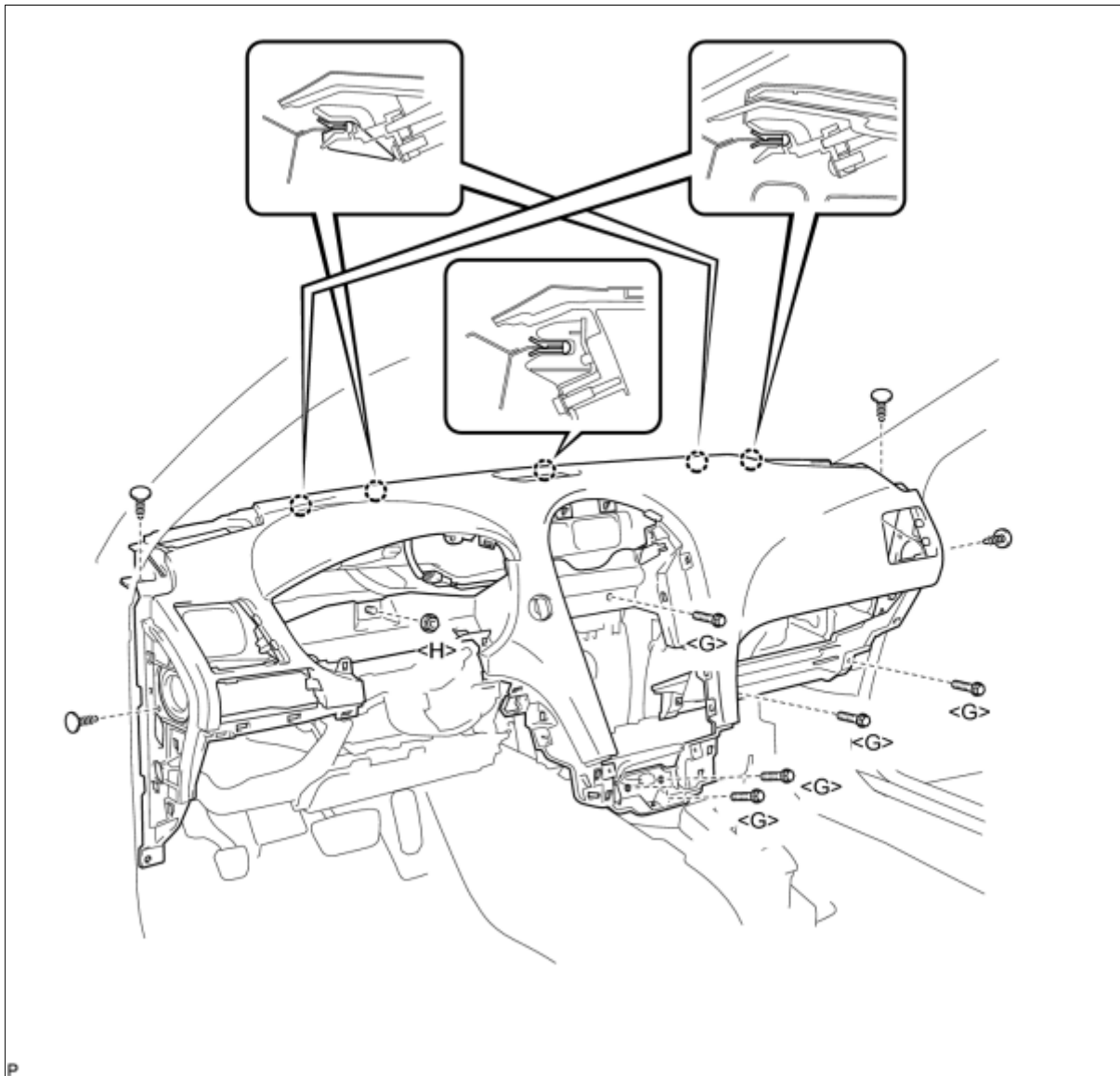

**53. REMOVE NO. 1 INSTRUMENT PANEL CLIP**

- (a) Disengage the 3 claws and remove the 3 No. 1 instrument panel clips.

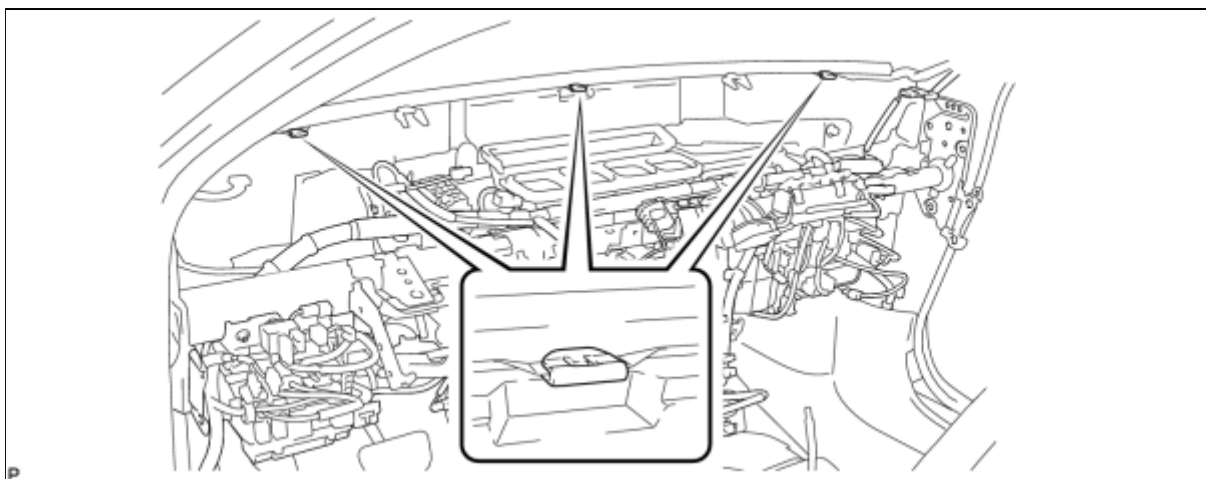

**54. REMOVE NO. 3 INSTRUMENT PANEL STAY**

- (a) Disengage the 2 claws and remove the 2 No. 3 instrument panel stays.

