

Last Modified: 7-13-2007		1.6 A
Service Category: Vehicle Exterior	Section: Door/Hatch	
Model Year: 2008	Model: ES350	Doc ID: RM0000011QF012X
Title: ENGINE HOOD / DOOR: FRONT DOOR: DISASSEMBLY (2008 ES350)		

DISASSEMBLY

1. REMOVE FRONT DOOR INSIDE HANDLE BEZEL PLUG

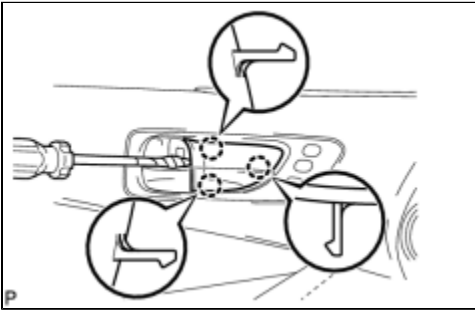

- (a) Using a screwdriver with the tip wrapped with protective tape, disengage the 3 claws, and remove the front door inside handle bezel plug.

2. REMOVE FRONT DOOR ARMREST BASE PANEL ASSEMBLY

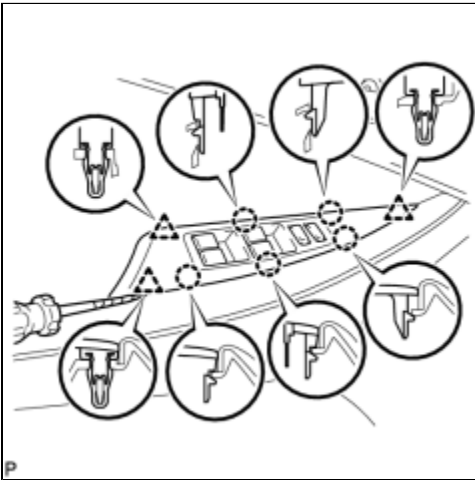

- (a) Using a screwdriver with the tip wrapped with protective tape, disengage the 5 claws and 3 clips, and remove the front door armrest base panel assembly.

- (b) Disconnect the connector.

3. REMOVE POWER WINDOW REGULATOR MASTER SWITCH ASSEMBLY (for Driver Side)

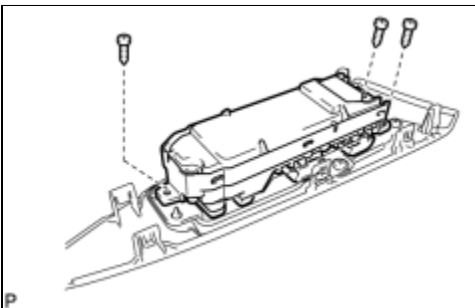

- (a) Remove the 3 screws and the power window regulator master switch assembly.

4. REMOVE POWER WINDOW REGULATOR SWITCH ASSEMBLY (for Front Passenger Side)

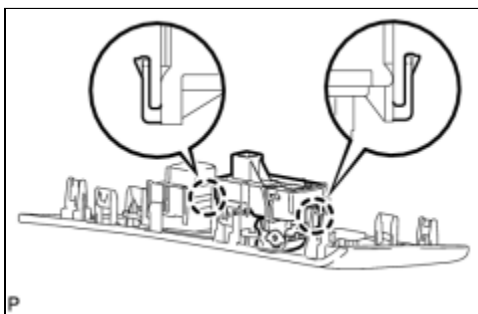

(a) Disengage the 2 claws and remove the power window regulator switch assembly.

5. REMOVE DOOR CONTROL SWITCH ASSEMBLY (for Front Passenger Side)

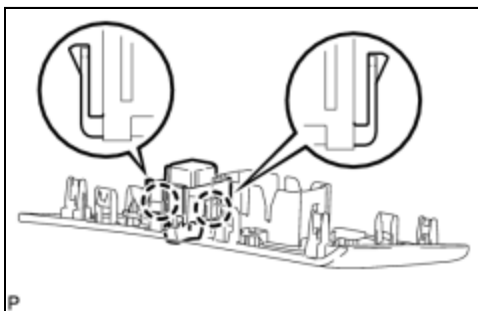

(a) Disengage the 2 claws and remove the door control switch assembly.

6. REMOVE COURTESY LIGHT ASSEMBLY

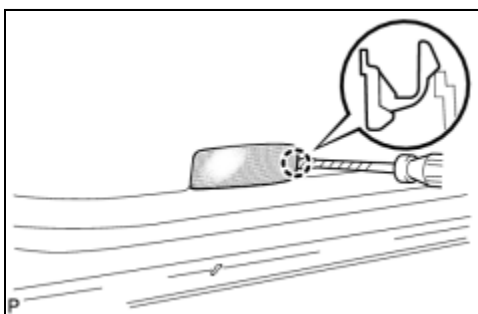

(a) Using a screwdriver with the tip wrapped with protective tape, disengage the claw and remove the courtesy light assembly.

(b) Disconnect the connector.

7. REMOVE DOOR ARMREST COVER

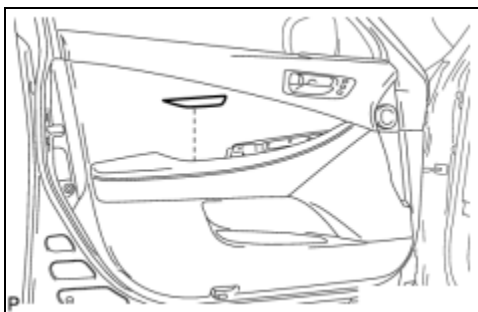

(a) Remove the door armrest cover.

8. REMOVE FRONT DOOR TRIM BOARD SUB-ASSEMBLY

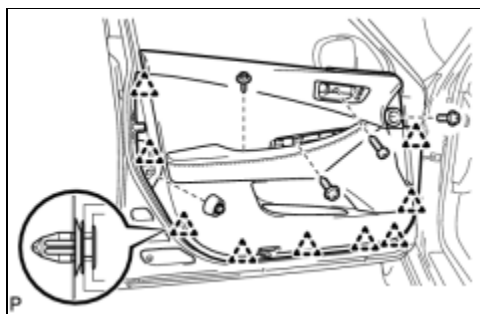

(a) Remove the 5 screws.

(b) Using a clip remover, disengage the 9 clips.

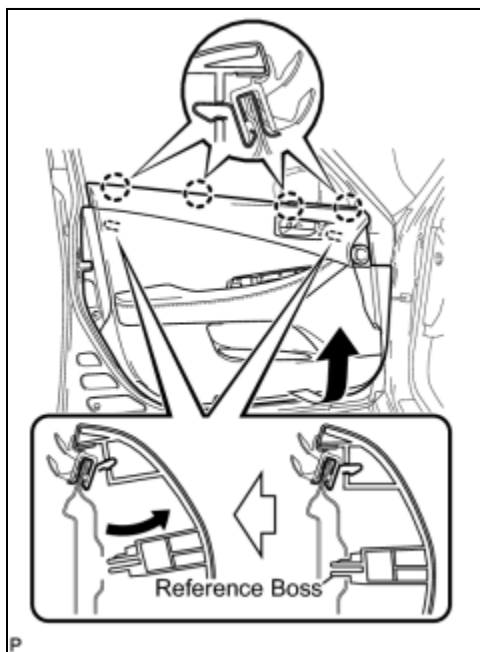

(c) Pull up the front door trim board in the direction indicated by the arrow.

(d) Disengage the reference bosses from the front door panel.

(e) Raise the front door trim board to disengage the 4 claws and remove the front door trim board together with the front door inner glass weatherstrip.

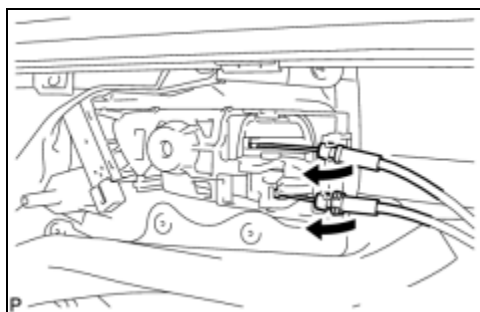

(f) Disconnect the cables and each connector from the back side of the inside handle and remove the front door trim board sub-assembly.

9. REMOVE FRONT DOOR INNER GLASS WEATHERSTRIP

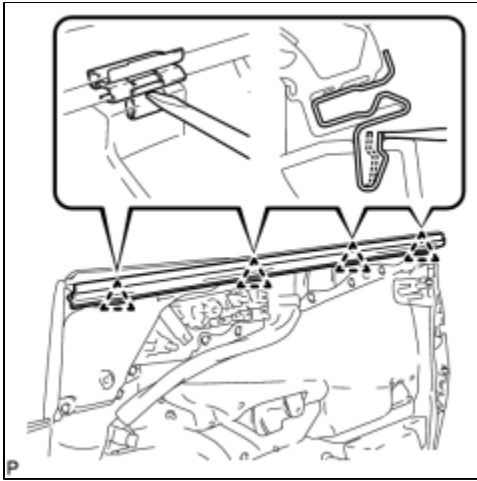

(a) Disengage the 4 clips as shown in the illustration and remove the front door inner glass weatherstrip from the front door trim board.

10. REMOVE SEAT MEMORY SWITCH (w/ Seat Position Memory System)



11. REMOVE DOOR FRAME GARNISH

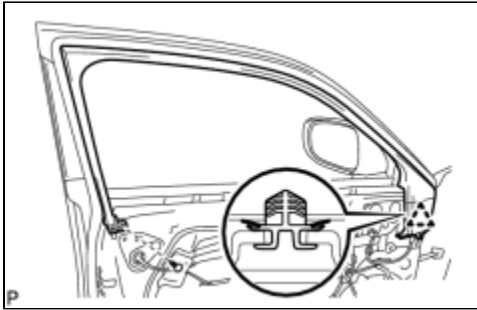

(a) Using a clip remover, remove the clip.

(b) Disengage the clip and remove the door frame garnish.

12. REMOVE OUTER MIRROR PROTECTOR

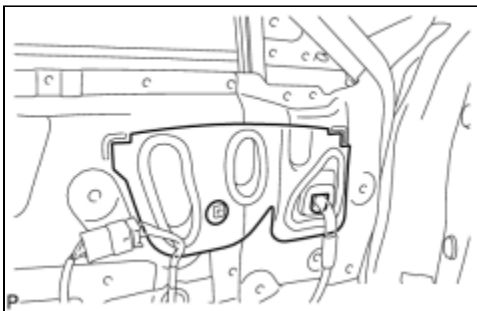

(a) Remove the outer mirror protector.

HINT:

Remove the remaining butyl tape on the door side.

13. REMOVE OUTER REAR VIEW MIRROR ASSEMBLY



14. REMOVE FRONT NO. 1 SPEAKER ASSEMBLY



15. REMOVE FRONT NO. 1 DOOR TRIM BRACKET

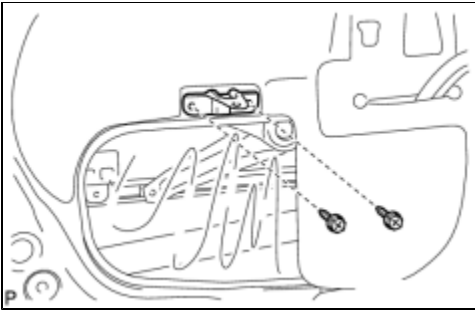

(a) Remove the 2 screws and the front No. 1 door trim bracket.

16. REMOVE FRONT DOOR SERVICE HOLE COVER

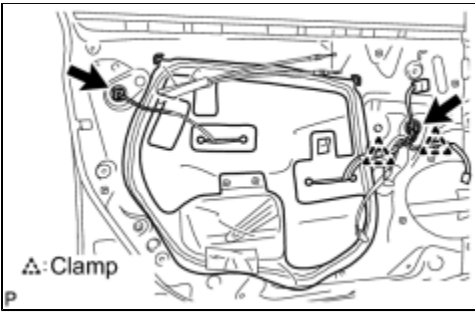

(a) Disconnect each connector and each clamp, and remove the front door service hole cover.

HINT:

Remove the remaining butyl tape on the door side.

17. REMOVE FRONT DOOR GLASS SUB-ASSEMBLY

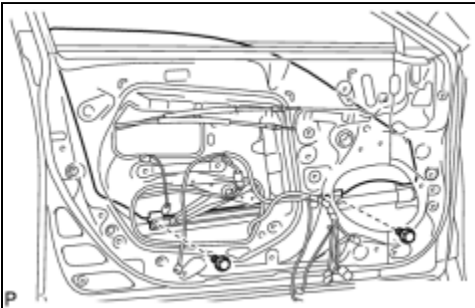

(a) Remove the 2 bolts.

NOTICE:

After the bolts are removed, the door glass may fall, causing damage.

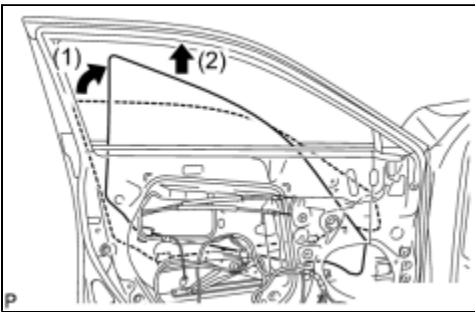

(b) Remove the front door glass sub-assembly as shown in the illustration.

NOTICE:

Do not damage the door glass.

18. REMOVE FRONT DOOR WINDOW REGULATOR SUB-ASSEMBLY

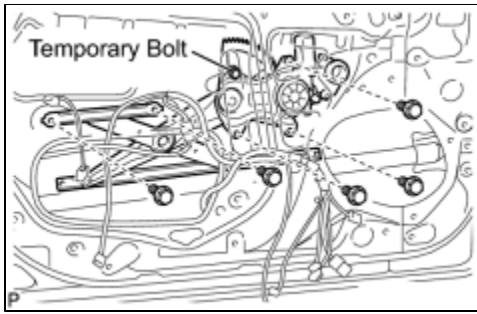

(a) Loosen the temporary bolt.

NOTICE:

Do not remove the temporary bolt. If the temporary bolt is removed, the front door window regulator may fall, causing damage.

(b) Remove the 5 bolts.

(c) Remove the front door window regulator sub-assembly and the front power window regulator motor assembly as a unit.

(d) Remove the temporary bolt from the front door window regulator sub-assembly.

19. REMOVE FRONT POWER WINDOW REGULATOR MOTOR ASSEMBLY

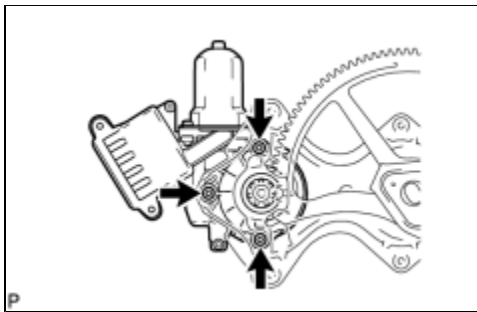

(a) Using a "TORX" driver (T25), remove the 3 screws and the front power window regulator motor assembly.

20. REMOVE FRONT NO. 1 DOOR STIFFENER CUSHION

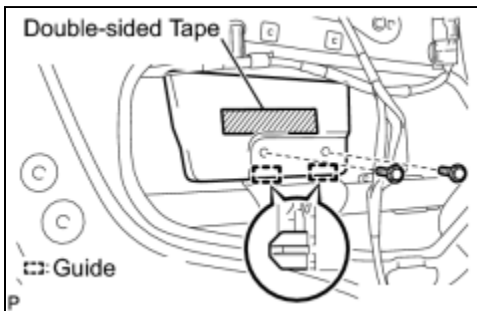

(a) Remove the 2 bolts.

(b) Remove the double-sided tape and the front No. 1 door stiffener cushion.

21. REMOVE FRONT DOOR GLASS RUN

(a) Remove the front door glass run.

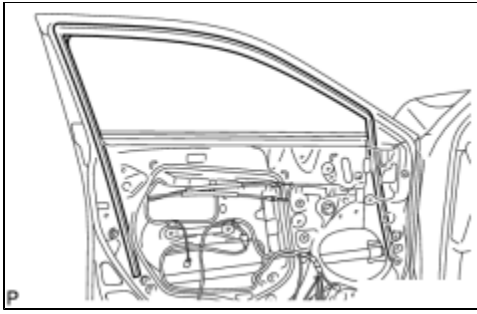

22. REMOVE FRONT DOOR FRONT LOWER FRAME SUB-ASSEMBLY

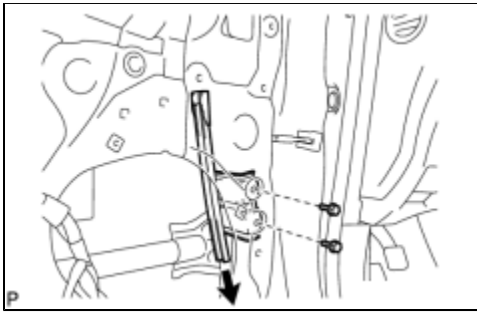

(a) Remove the 2 bolts and the front door front lower frame sub-assembly as shown in the illustration.

23. REMOVE FRONT DOOR REAR LOWER FRAME SUB-ASSEMBLY

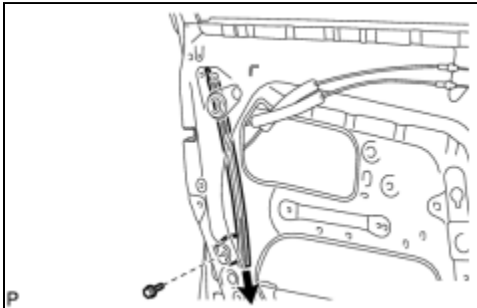

(a) Remove the bolt and the front door rear lower frame sub-assembly as shown in the illustration.

24. REMOVE FRONT DOOR OUTSIDE HANDLE COVER (for Driver Side)

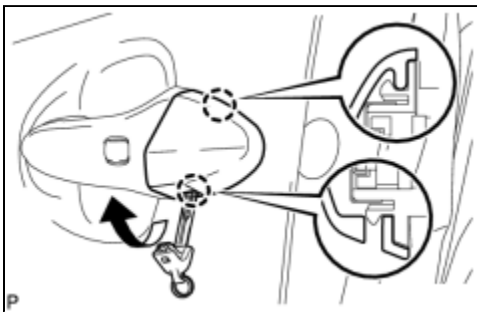

(a) Using an emergency key, disengage the 2 claws and remove the front door outside handle cover.

25. REMOVE FRONT DOOR OUTSIDE HANDLE COVER (for Front Passenger Side)

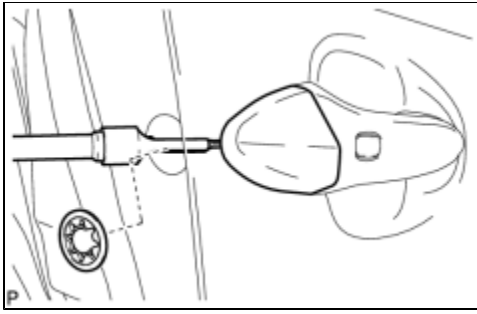

(a) Remove the hole plug.

(b) Using a "TORX" socket wrench (T30), loosen the screw and remove the front door outside handle cover.

HINT:

The screw cannot be removed because it is integrated into the front door outside handle frame sub-assembly.

26. REMOVE FRONT DOOR OUTSIDE HANDLE ASSEMBLY

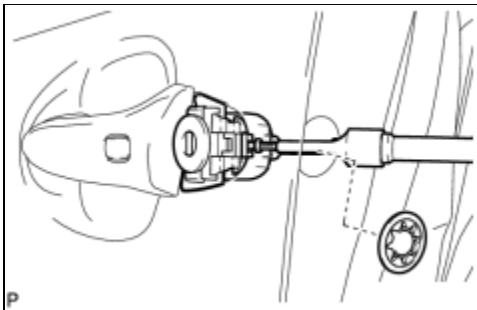

(a) Remove the hole plug.

(b) Using a "TORX" socket wrench (T30), loosen the screw and remove the front door outside handle cover and the door lock key cylinder as a unit.

HINT:

The screw cannot be removed because it is integrated into the front door outside handle frame sub-assembly.

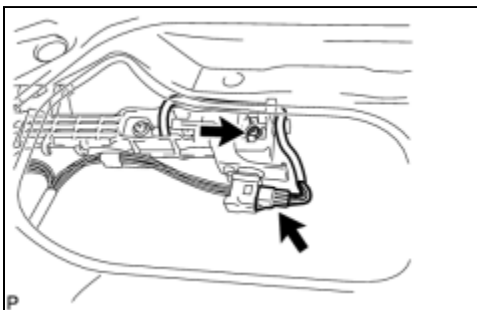

(c) Disconnect the connector.

(d) Using a "TORX" socket wrench (T30), loosen the screw.

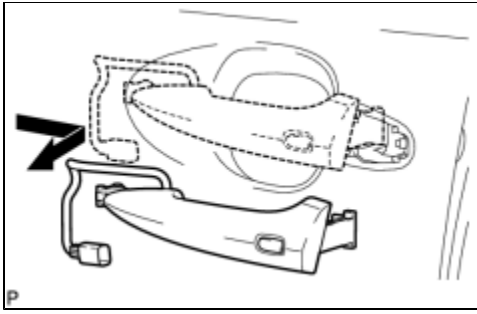

(e) Remove the front door outside handle assembly as shown in the illustration.

27. REMOVE FRONT DOOR FRONT OUTSIDE HANDLE PAD

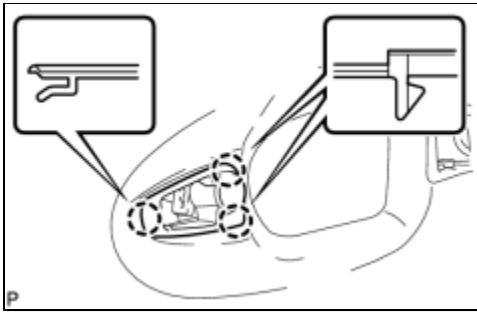

(a) Disengage the 3 claws and remove the front door front outside handle pad.

28. REMOVE FRONT DOOR REAR OUTSIDE HANDLE PAD

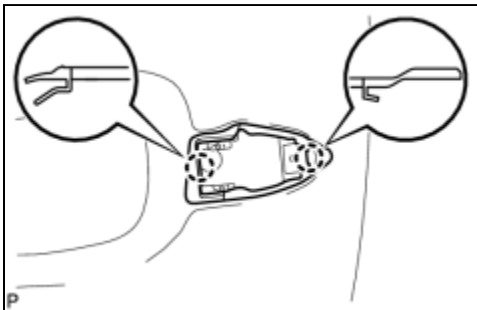

(a) Disengage the 2 claws and remove the front door rear outside handle pad.

29. REMOVE FRONT DOOR LOCK ASSEMBLY

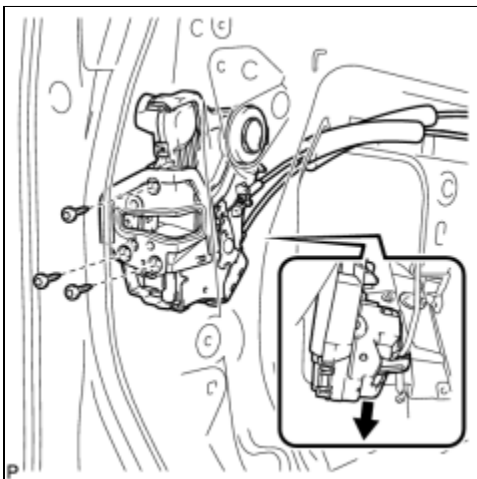

(a) Using a "TORX" socket wrench (T30), remove the 3 screws.

- (b) Slide the front door lock assembly downward, pull out the front door lock open rod from the outside handle frame, and remove the front door lock assembly and cables as a unit.
- (c) Remove the front door lock open rod from the front door lock assembly.
- (d) Remove the door lock wiring harness seal from the front door lock assembly.

30. REMOVE FRONT DOOR LOCK REMOTE CONTROL CABLE ASSEMBLY

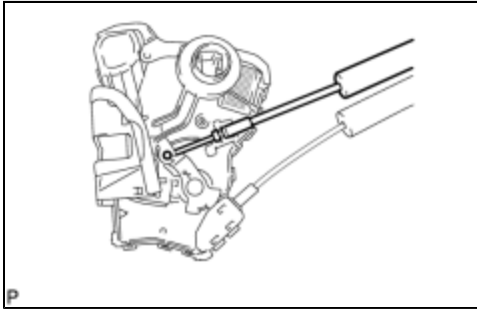

- (a) Remove the front door lock remote control cable assembly.

31. REMOVE FRONT DOOR INSIDE LOCKING CABLE ASSEMBLY

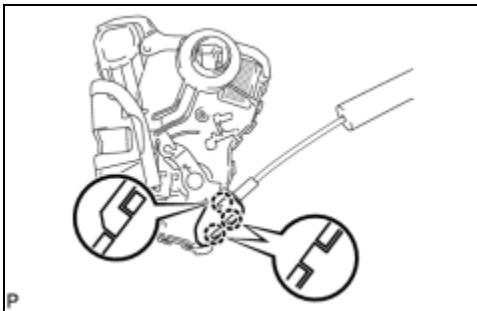

- (a) Using a screwdriver, disengage the 3 claws.

HINT:

Tape the screwdriver tip before use.

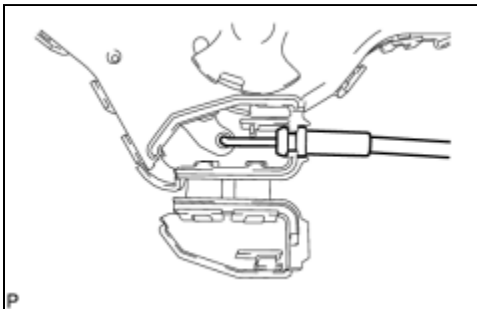

- (b) Remove the front door inside locking cable assembly.

32. REMOVE FRONT DOOR OUTSIDE HANDLE FRAME SUB-ASSEMBLY

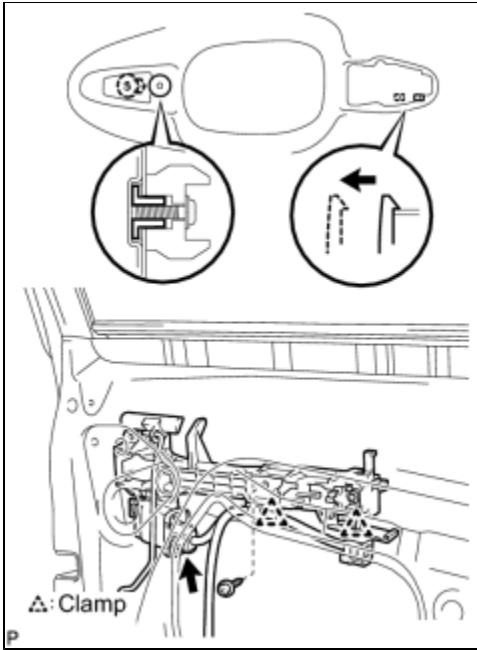

(a) Using a "TORX" socket wrench (T30), loosen the screw.

HINT:

The screw cannot be removed because it is integrated into the front door outside handle frame sub-assembly.

(b) Disconnect the connector.

(c) Disengage the 2 clamps.

(d) Disengage the claw and remove the front door outside handle frame sub-assembly.

33. REMOVE FRONT DOOR LOCK OPEN ROD

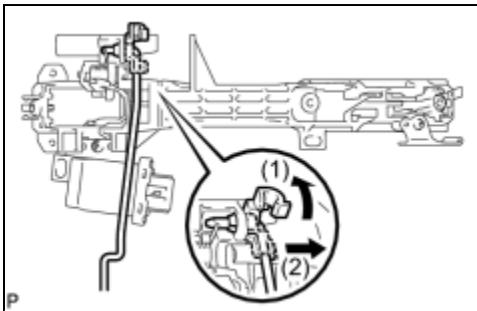

(a) Remove the front door lock open rod as shown in the illustration.

34. REMOVE DOOR ELECTRICAL KEY OSCILLATOR

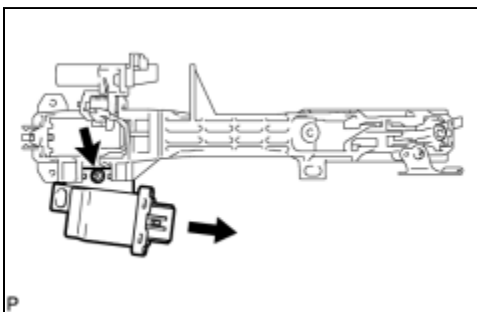

(a) Remove the screw and door electrical key oscillator.

35. REMOVE FRONT DOOR CHECK COVER

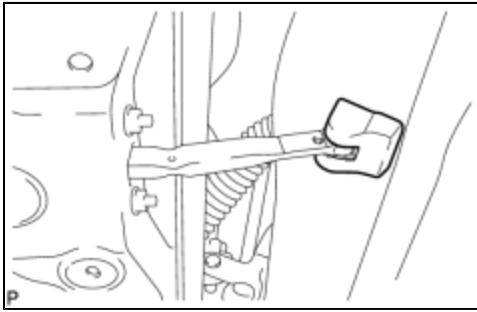

(a) Remove the front door check cover.

36. REMOVE FRONT DOOR CHECK ASSEMBLY

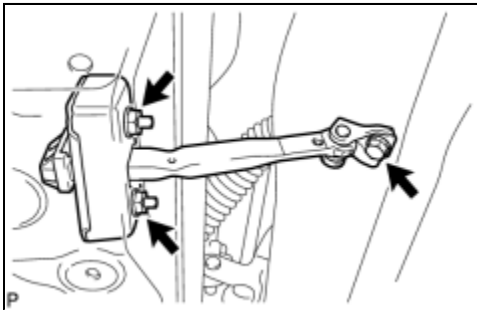

(a) Remove the bolt, 2 nuts, and front door check assembly.

37. REMOVE FRONT NO. 3 DOOR WEATHERSTRIP

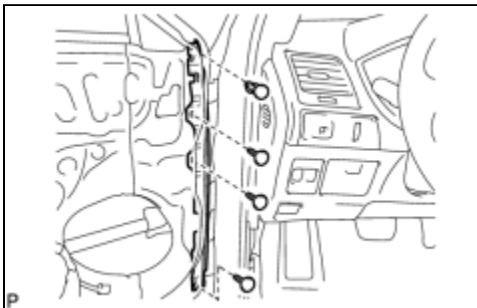

(a) Using a clip remover, disengage the 4 clips and remove the front No. 3 door weatherstrip.

38. REMOVE FRONT DOOR WEATHERSTRIP

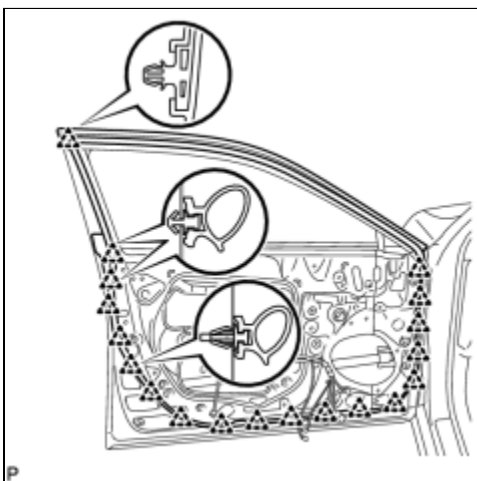

(a) Using a clip remover, disengage the 19 clips and remove the front door weatherstrip.

39. REMOVE FRONT DOOR BELT MOULDING ASSEMBLY



40. REMOVE FRONT DOOR REAR WINDOW FRAME MOULDING



41. REMOVE FRONT DOOR FRONT LOWER FRAME UPPER COVER



42. REMOVE FRONT DOOR OUTSIDE MOULDING SUB-ASSEMBLY



43. REMOVE FRONT DOOR LOWER OUTSIDE MOULDING

