

Last Modified: 7-13-2007		1.6 A
Service Category: Power Source/Network	Section: Battery/Charging	
Model Year: 2008	Model: ES350	Doc ID: RM000002EQX002X
Title: 2GR-FE CHARGING: GENERATOR: REMOVAL (2008 ES350)		

REMOVAL

1. DISCONNECT CABLE FROM NEGATIVE BATTERY TERMINAL
2. REMOVE FRONT WHEEL RH
3. REMOVE COOL AIR INTAKE DUCT SEAL [INFO](#)
4. REMOVE ENGINE ROOM SIDE COVER LH [INFO](#)
5. REMOVE ENGINE ROOM SIDE COVER RH [INFO](#)
6. REMOVE V-BANK COVER SUB-ASSEMBLY [INFO](#)
7. REMOVE FRONT FENDER APRON SEAL RH
8. REMOVE FRONT WHEEL OPENING EXTENSION PAD LH
9. REMOVE FRONT WHEEL OPENING EXTENSION PAD RH
10. REMOVE ENGINE UNDER COVER LH
11. REMOVE ENGINE UNDER COVER RH
12. DRAIN ENGINE COOLANT [INFO](#)
13. REMOVE AIR CLEANER CAP SUB-ASSEMBLY [INFO](#)
14. REMOVE NO. 2 AIR CLEANER INLET [INFO](#)
15. REMOVE NO. 1 AIR CLEANER INLET [INFO](#)
16. REMOVE FRONT BUMPER ASSEMBLY [INFO](#)
17. REMOVE FRONT BUMPER ENERGY ABSORBER [INFO](#)
18. REMOVE MILLIMETER WAVE RADAR SENSOR ASSEMBLY (w/ Dynamic Radar Cruise Control System) [INFO](#)
19. SEPARATE RADIATOR RESERVOIR TANK HOSE [INFO](#)
20. DISCONNECT RADIATOR HOSE INLET [INFO](#)
21. DISCONNECT RADIATOR HOSE OUTLET [INFO](#)

22. DISCONNECT NO. 1 OIL COOLER INLET HOSE INFO

23. DISCONNECT NO. 1 OIL COOLER OUTLET HOSE INFO

24. REMOVE RADIATOR SUPPORT UPPER INFO

25. REMOVE FAN SHROUD INFO

26. REMOVE RADIATOR ASSEMBLY INFO

27. REMOVE V-RIBBED BELT INFO

28. REMOVE GENERATOR ASSEMBLY

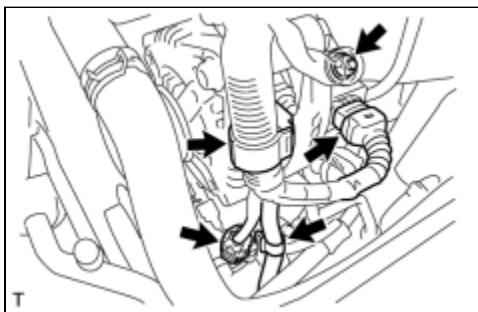

(a) Remove the terminal cap.

(b) Remove the nut and disconnect the wire harness from terminal B.

(c) Disconnect the generator connector from the generator assembly.

(d) Disconnect the connector from the compressor and magnetic clutch.

(e) Disconnect the 2 wire harness clamps.

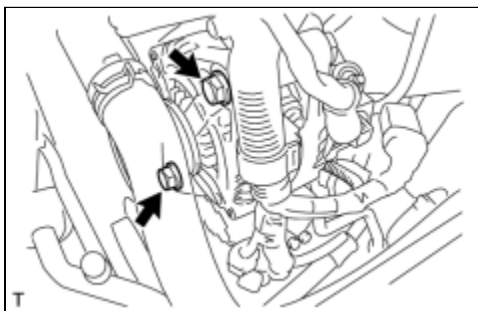

(f) Remove the 2 bolts.

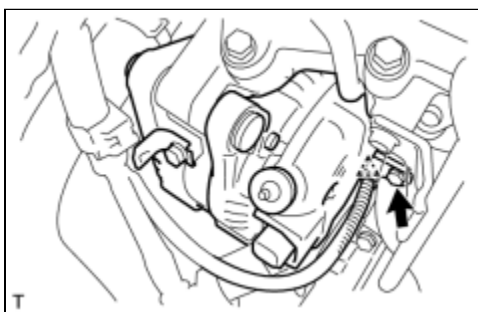

(g) Remove the bolt from the cylinder block.

(h) Disconnect the wire harness clamp and remove the generator assembly.

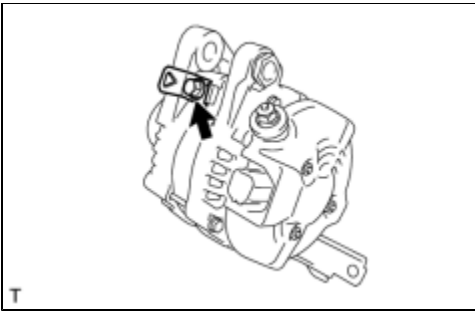

(i) Remove the bolt and wire harness clamp stay.

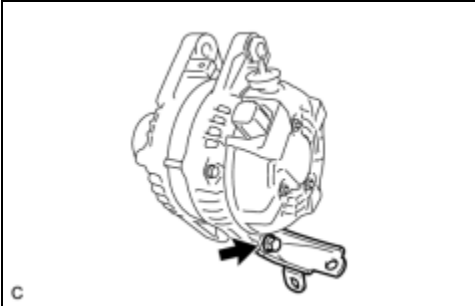

(j) Remove the bolt and bracket.

